

# Gizmo+A3

## User Manual



**“Beyond Usual Conditions”**



# Gizmo+A3

## ELEVATOR CONTROL BOARD INSTALLATION AND USER MANUAL



Serial No:.....

Hardware Version: 3.00

Software Version: 1.00

User Manual Version: 2.10

NOTE: Make sure that serial numbers of this user guide and the product are the same. Otherwise, the product you use and the explanations given here may not match.

**Terminal Numbers and their Meanings on Gizmo+A3 Control Board**

<b>R,S,T</b>	: Main Phases
<b>MP</b>	: Neutral
<b>10A</b>	: Safety circuit return
<b>120</b>	: Stop Circuit return, Door Contact start
<b>130</b>	: Door Contact return, Door Lock Circuit start
<b>140</b>	: Door Lock Circuit return
<b>10B</b>	: Neutral connection of contactors
<b>11</b>	: Common terminals of RU1, RU2, RH, RF relays
<b>RU1</b>	: Down direction relay for roped lifts, or down-fast relay and connection terminal for hydraulic lifts.
<b>RU2</b>	: Upward direction relay for roped lifts, or upward-fast relay and connection terminal for hydraulic lifts.
<b>RH</b>	: Fast relay for roped lifts, or downward-slow relay and connection terminal for hydraulic lifts.
<b>RF</b>	: Slow relay for roped lifts, or upward-slow relay and connection terminal for hydraulic lifts.
<b>RPB</b>	: Contactor supply terminal for hydraulic and VVVF controlled lifts.
<b>RPA</b>	: Connection terminal for contactor signals of hydraulic and VVVF controlled lifts.
<b>LIR1, LIR2</b>	: Normally-open (NO) terminals of LIR pump relay.
<b>1, 2</b>	: Normally-open terminals of car lamp relay
<b>RTC</b>	: Delta connection point for hydraulic lifts.
<b>RTC0M</b>	: Star/delta contactor supply in hydraulic lifts, or regulator inductor common input terminal in VVVF controlled lifts.
<b>RTO</b>	: Star connection point in hydraulic lifts, or regulator inductor connection terminal in VVVF controlled lifts.
<b>RSA</b>	: Common connection terminal of leveling speed signal in VVVF controlled lifts.
<b>RSB</b>	: Connection terminal for leveling speed signal output in VVVF controlled lifts.
<b>A3</b>	: Close signal for Door A ( <i>common terminal is AB15</i> )
<b>A5</b>	: Open signal for Door A ( <i>common terminal is AB15</i> )
<b>AB15</b>	: Common terminal of A3-A5 and B3-B5
<b>B3</b>	: Close signal for Door B ( <i>common terminal is AB15</i> )
<b>B5</b>	: Open signal for Door B ( <i>common terminal is AB15</i> )
<b>GND</b>	: Encoder supply (-12V DC)
<b>12V</b>	: Encoder supply (+12V DC)
<b>A-</b>	: Encoder signal
<b>A+</b>	: Encoder signal
<b>B-</b>	: Encoder signal
<b>B+</b>	: Encoder signal
<b>100</b>	: +24V DC
<b>1000</b>	: Common terminal of 100 signal (-24 Volt)
<b>KAK</b>	: Rescue contactor supply
<b>SAK</b>	: Grid contactor supply
<b>RLC</b>	: COM signal for KAK and SAK relays
<b>DISPLAY</b>	: Flat cable connection to transfer display signals of G0,G1,G2,G3,01,02,31 and 32 to TERMINAL board.
<b>COMM.</b>	: Flat cable connection to transfer CARCOMM car-top communication board and group operation communication signals to TERMINAL board.
<b>CALLS</b>	: Flat cable connection to get call signals from the TERMINAL board.
<b>SIGNALS 2</b>	: Flat cable connection to get signals from TERMINAL board.
<b>SIGNALS 1</b>	: Flat cable connection to get signals from TERMINAL board.
<b>M0</b>	: M0 counter bistable switch input ( <i>common terminal is 100</i> )
<b>M1</b>	: M1 counter bistable switch input ( <i>common terminal is 100</i> )
<b>141</b>	: JF1 slowdown bistable switch input ( <i>common terminal is 100</i> )
<b>142</b>	: JF2 slowdown bistable switch input ( <i>common terminal is 100</i> )
<b>817</b>	: Down limit final bistable switch ( <i>common terminal is 100</i> )
<b>818</b>	: Upper limit final bistable switch ( <i>common terminal is 100</i> )
<b>804</b>	: Over load contact ( <i>common terminal is 100</i> )
<b>805</b>	: Full load contact ( <i>common terminal is 100</i> )
<b>812</b>	: Car attendant contact ( <i>common terminal is 100</i> )
<b>815</b>	: Earthquake contact ( <i>common terminal is 100</i> )
<b>816</b>	: Fire contact ( <i>common terminal is 100</i> )
<b>K20</b>	: Automatic door open button, photocell contact, thrust force contact ( <i>common terminal is 100</i> )
<b>DTS</b>	: Automatic door close button ( <i>common terminal is 100</i> )

<b>869</b>	: Well inspection switch ( <i>common terminal is 100</i> )
<b>500</b>	: Inspection downward button ( <i>common terminal is 100</i> )
<b>501</b>	: Inspection upward button ( <i>common terminal is 100</i> )
<b>RGA</b>	: Regulator watching input ( <i>common terminal is 100</i> )
<b>RGK</b>	: Regulator watching input ( <i>common terminal is 100</i> )
<b>BRK</b>	: Motor brake logging input ( <i>common terminal is 100</i> ) (Used in the case of gearless motor)
<b>ST</b>	: Used to determine rescue direction ( <i>common terminal is 100</i> )
<b>ML1</b>	: Monostable magnetic switch input in hydraulic and VVVF controlled systems
<b>ML2</b>	: Monostable magnetic switch input in hydraulic and VVVF controlled systems ( <i>common terminal is 100</i> )
<b>CL</b>	: Door open limit ( <i>common terminal is 100</i> )
<b>OL</b>	: Door closed limit ( <i>common terminal is 100</i> )
<b>KRC</b>	: Contactor control (KRC) signal input ( <i>common terminal is 100</i> )
<b>PTC</b>	: Motor thermistor connection ( <i>common terminal is 100</i> )

### **Terminal Numbers and Meanings in Gizmo+A3 TERMINAL Board**

<b>A,B,C,D,E,F,G,2G,2BC</b>	: Display outputs ( <i>common terminal is 100</i> )
<b>02</b>	: Out-of-service lamp ( <i>common terminal is 1000</i> )
<b>12</b>	: Busy lamp ( <i>common terminal is 1000</i> )
<b>31</b>	: Downward direction arrow lamp ( <i>common terminal is 1000</i> )
<b>32</b>	: Upward direction arrow lamp ( <i>common terminal is 1000</i> )
<b>G0-G3</b>	: Gray code output to show floor number
<b>X01-X16</b>	: Call terminals ( <i>common terminal is 100, signal common terminal is 1000</i> )
<b>K869</b>	: Inspection from the well
<b>P869</b>	: Inspection from the panel
<b>142K</b>	:
<b>SC1A-SC1B</b>	: Used for connection to CARCOMM car-top serial communication board
<b>SC2A-SC2B</b>	: Used for group operation communication

WARNING: The default adjustment of the common terminals for low arrow, up arrow, busy and out-of-service lamps are 1000. Optionally, the common terminal can be adjusted as 100 from the jumpers over GIZMO+A3.

### **TERMINAL NUMBERS AND MEANINGS ON CONTROL PANEL:**

<b>R,S,T</b>	: Main phases
<b>Mp</b>	: Neutral
<b>PE</b>	: Earthing
<b>U1,VI,W1</b>	: High speed motor outputs for roped lifts, or motor winding terminals for hydraulic lifts.
<b>U2,V2,W2</b>	: Low speed motor outputs for roped lifts, or motor winding terminals for hydraulic lifts..
<b>100</b>	: +24 Volt
<b>1000</b>	: Common terminal of 100 signal (-24 Volt)
<b>FR+,FR-</b>	: Brake winding terminals
<b>PO+,PO-</b>	: Pump winding terminals
<b>1</b>	: Direct phase
<b>1</b>	: Direct phase at top of car
<b>2</b>	: Car lamp
<b>110</b>	: Start of safety circuit
<b>111,112,113</b>	: Null connection terminals
<b>120</b>	: Stop Circuit return, Door Contact start
<b>130</b>	: Door Contact return, Door Lock start
<b>140</b>	: Door Lock return
<b>A3</b>	: closing signal for Door A ( <i>common terminal is AB15</i> )
<b>A5</b>	: opening signal for Door A ( <i>common terminal is AB15</i> )
<b>AB15</b>	: common terminal for A3-A5 and B3-B5
<b>B3</b>	: closing signal for Door B ( <i>common terminal is AB15</i> )
<b>B5</b>	: opening signal for Door B ( <i>common terminal is AB15</i> )
<b>24+,24-</b>	: 24 V DC door opening voltage if rescue device is present on the panel.

**INDEX**

1) INTRODUCTION .....	6
2) PRODUCT FEATURES .....	6
3) LCD SCREEN AND KEYPAD .....	8
4) USAGE OF MENUS IN GIZMO+A3 LIFT CONTROL BOARD .....	8
5) PARAMETERS .....	9
6) PARAMETER DESCRIPTIONS .....	11
7) ERROR CODES .....	22
8) WELL LEARNING PROCEDURE .....	24
9) FREQUENTLY ASKED QUESTIONS (F.A.Q.) .....	26
10) IMPORTANT CONSIDERATIONS DURING INSTALLATION .....	27
11) IMPORTANT CONSIDERATIONS IN CONNECTION OF CONTROL PANEL TO LIFT SYSTEM AND MAKING THE SYSTEM OPERATIONAL .....	28
11-1) Important Considerations in Connecting Control Panel to Lift system .....	28
11-2) Important Considerations on Preparing the System Become Operational .....	28
12) MAINTENANCE and CLEANING of Gizmo+A3 CONTROL BOARD .....	29
13) SAFETY NOTES .....	29
14) DRAWING AND DIAGRAMS.....	31

*Dear Customer,*

*Thank you for choosing Gizmo+A3 Controller Board manufactured in our modern facilities. We would like to present you the most effective products by employing the most advanced technology and devoting supreme quality control. For obtaining best performance, please read this document carefully prior to start installation and keep it as a reference for further requirements.*

*We devote our efforts for correct installation and use of our products in long term. We also keep updating and expanding our documents consistently. All technical drawings are controlled thoroughly before presented to you. Despite our best efforts to ensure that the information given in this document is accurate, there may still be some mistakes. To help us steer clear from mistakes, please inform us immediately if you encounter any mistake in the document, especially with the drawings to help us.*

*Please follow the link to our website in [www.eem.com.tr](http://www.eem.com.tr) to be alerted for our new products and updated informaton.*

*We hope you find our products to be a valuable tool in your business.*

**WARNING ! :** All documents in this user guide is intended for providing advice. Despite our best efforts, it may contain mistakes and flaws. Please verify all the information given, and thoroughly question them before applying.

## **1. INTRODUCTION**

Gizmo+A3 lift control card is a microcontroller-based electronic lift control system. The board can be used in controlling one-speed, two-speed, roped VVVF (with synchronous or induction machine) and hydraulic lifts. A terminal connection board named TERMINAL comes with Gizmo+A3 control board to be used for straightforward connection of control board terminals to control panel. By means of EASYCALL board, easy and accurate call assignments can be given to the lift during repair-maintenance.

## **2. PRODUCT FEATURES**

- Learning the well using encoder
- Depending on the type of the lift, employing different application macros provides usage convenience and superior performance for every kind of lift.
- Floor adjustment can be made on the interior of the car.
- Control type can be adjusted.
- Number of stops can be adjusted.
- 16 stops are standard, expanded to 32 stops
- By including the Additional Call Board, call inputs and floor capacity can be increased.
- Call lamp and buttons can be connected to the system by a single cable.
- All parameters can be easily adjusted by program buttons and LCD screen.
- Simple and flawless installation provide savings of time and control panel terminals
- Incorporates short-circuit protected display outputs, in which desired code can be adjusted for each stop.
- Over-load function is available.
- Full-load function is available.
- Attendant switch function is available.
- In case of fire, the lift can be directed to pre-adjusted stop.
- Manuel motion in low speed using program buttons.
- Adjustable parking stop and park travel time is available.
- As the floor selection, M0 counter, M1 counter, ML1&ML2 counter and Encoder Mode is available.
- 4-channel encoder input for position info.
- Adjustable position resel feature is available.
- When the door stays open for a long time, warning function on the LCD is available.
- Following features are available; Adjustable busy time, wait time on the floor, door lock wait time, door stay-open time, give error time for door stay-open, parking time, maximum high speed time and maximum low speed time.
- Besides classical seven-segment display outputs, GRAY, BINARY or OUTPUT ON-THE-FLOOR outputs can be obtained for different models of pushbuttons.
- In the same manner, besides obtaining seven-segment display outputs from CARCOMM serial communication board, GRAY, BINARY or OUTPUT ON-THE-FLOOR outputs can also be obtained.
- GRAY code output for external usage.
- Ability of displaying the target stop in each floor change.
- For protection, password query can be activated.
- By the help of CARCOMM Serial Communication Board, only 2 cable is used for communication and saving from flexible cable is provided.
- It can operate in group mode up to 6 cars
- Call transfer in group operation

- The selection feature to move the car either up to the limit switches or to the floor level.
- Automatic door type can be chosen and Open/Closed standby position of full-automatic door can be adjusted. Also, automatic door type can be adjusted separately for each floor. Thus, for example ground floor and 1st floor can be adjusted full-automatic and garage floor can be semi-automatic. Besides the door can be kept open in ground floor, and kept closed in the 1st floor.
- Second door support is available with internal second door relay. Just like the first door, automatic door type can be chosen separately for each floor. Thus, for example ground floor and 1st floor can be full-automatic, garage floor can be operated semi-automatic. Again also, in standby door can wait open in ground floor and closed in 1st floor.
- For lifts having only one full-automatic door, the floor number the full-automatic door is present can be chosen.
- It can be operated up to 3.0 m/s.
- It can operate smoothly in hydraulic lifts whose motor is driven by star-delta or soft starter.
- In star-delta hydraulic lifts, star-delta time, starting valve delay, stopping motor delay and stopping valve delay times can be separately adjusted.
- In hydraulic lifts with soft start, adjustable soft starter contactor delay is available.
- By the help of internal shunting relays, for roped or hydraulic lifts, door pre-opening can be made.
- By the help of internal shunting relays, for roped or hydraulic lifts, door-open leveling can be made.
- Electronical control of phases, phase sequence and PTC (Motor temperature), displaying of errors occurred related with these controls on the LCD screen over the board, disabling these functions with parameter selection, adjustment of phase level precision.
- Fast call assignment by the internal EASYCALL board.
- Optional SONIC Announcement board
  - Integrated operation with CARCOMM board
  - Simple installation requiring only a loudspeaker connection
  - Announcement is possible for floor info, over load, out-of-service, rescue mode, photocell interruption. It can play music during the travel. Turkish/English/Arabic language options are available.
  - Arranging all announcements and musics by MicroSD card support and computer interface.
- Adjustable maintenance time, LCD screen warning when the maintenance time exceeded.
- Stores the most recent 20 errors
- Suitable for horizontal and vertical use.
- Turkish, English and Spanish language options are available as a standard. (Software version 1.00 product is available in one language options.)

### **3. LCD SCREEN AND KEYPAD**

Gizmo+A3 lift control board incorporates two-line 16 character LCD screen and LCD DISPLAY board with four push-buttons to make it possible both horizontal and vertical use of the board. The pushbuttons are designated as ENTER, ESC, UP and DOWN keys.

EEM Engineering  
Version:1.00

EEM Engineering  
GIZMO+A3 Control

Call Waiting...  
d01→h-- 24V

UP Fast Travel  
d01→h05 24V

When the system is powered, LCD screen displays messages named “Initialize Screen”. In the first message, our company and product names are displayed followed by the version number of the product. In the third message, the serial number of the board used is shown. Each of these screens are displayed for one second and then the screen we will call “Main screen” is displayed.

In the main screen, it is shown that calls are awaited and the transformer output voltage supplying control signals can be seen. In this screen, “d” denotes the stop where the car is located and “h” denotes the target stop of the car.

For example, while the car is located in the 1st stop, if it gets a call from 5th stop, after the lift initiates its run, the screen shown to the left side is displayed.

### **4. USAGE OF MENUS IN GIZMO+A3 LIFT CONTROL BOARD**

In Gizmo+A3 lift control card, all parameters are grouped and numbered. Hence, reaching any parameter, displaying its value and changing it are extremely easy.

0-DiL/LANGUAGE

1-Lift Type  
Roped VVVF

1-Lift Type  
Hydraulic

When Gizmo+A3 is in standby mode in main screen, menu is entered by present ENTER for 3 seconds. Here, the screen shown in the left is displayed. User can browse in main menu using UP, DOWN keys. ENTER key can be pressed to enter in the desired parameter group.

For example, to enter into the 2nd parameter, when ENTER is pressed, the 2nd parameter appears as shown to the left. Similarly, UP, DOWN buttons can be used to browse in the parameters. To change the desired parameter, ENTER key is pressed to get into this parameter. When ENTER key is pressed, the display blinks to show that it is active. Then, it is possible to change the parameter using UP, DOWN buttons.

After making the changes, ENTER key is pressed to accept the changes or ESC key can be pressed to cancel the changes to exit the current menu. The screen becomes stable and the changes are confirmed and immediately becomes active. Similarly, after making all adjustments, ESC key can be pressed to exit the menu.

## **5. PARAMETERS**

To meet the demands of the lifts on the field, a large number of adjustable parameters are provided to the user. As there are a large number of adjustable parameters, for ease of use, they have been classified in terms of their characteristics and/or functions. For this concern, compared with the similar systems, reaching at a parameter and changing its value is more practical and simple.

P.No	Parameter Name	Value Interval	Default Values
0	DİL-LANGUAGE	Türkçe English	English (Software version 1.00 product is available in one language options.)
1	Lift Type	One Speed Double Speed Roped VVVF Hydraulic	Roped VVVF
2	Control Type	Simple Collective Complex Collective Down Collective Full Collective Duplex Special	Complex Collective
3	Number of Stops	1-16	16
4	Number of basements	0-14	0
5	Door Type	Swing Door Car-AutoLimited Car-AutoNoLimit Full-AutoLimited Full-AutoNoLimit	Full-AutoLimited
6	Busy Time	5-20 Second	6 Second
7	Lock Wait Time	2-30 Second	10 Second
8	Waiting on Floor	3-15 Second	5 Second
9	Fast Travel Time	5-250 Second	15 Second
10	Slow Travel Time	10-50 Second	10 Second
11	Door Open Stay Time	15-250 Second	20 Second
12	Parking Time	10-250 Second	250 Second
13	Parking Stop	Cancel-16	Cancel
14	Fire Stop	Cancel -16	1
15	Arrow Animation	Active Passive	Passive
16	Change PIN		
17	Cancel PIN		
18	Service Reset		
19	Service Time	45-250 Days	45 Days
20	Errors		
21	Display Settings		
22	Door Floor Setting		
23	Rescue	Active Passive	Passive

**GIZMO+A3 PARAMETERS**

**EEM Imp. Exp. Trade Co. – Lift Controller System**

Fevzi Çakmak Mah. MODESA Sanayi Sitesi 10735. Sok .No:3 Karatay / KONYA / Türkiye

Tel: +90 332 346 46 56-66 Fax: +90 332 346 46 76

P.No	Parameter Name	Value Interval	Default Values
24	Dublex Select	Simplex Panel [A] Panel [B] Panel [C] Panel [D] Panel [E] Panel [F]	Simplex
25	Call Transfer	Active Passive	Passive
26	Phase Protection	Disabled Without Phase Sequence With Phase Sequence	Without Phase Sequence
27	PTC	Active Passive	Active
28	Car Serial Communication	Active Passive	Passive
29	Door Open Time	3-20 Second	5 Second
30	Full Auto Door Select	Cancel-16	Cancel
31	RP Wait Time	0-25000 milisaniye	3500 ms
32	InspectionMovement	UpToLimitSwitch UpTofloor	UpToLimitSwitch
33	Door Pre-Opening	Active Passive	Passive
36	Re-Leveling	Active Passive	Passive
37	First Stop	1-14	1
38	Pre-Opening Distance	10-150	50
39	Display Animation	Active Passive	Passive
40	Display Output Type	7 Segment Gray Code Binary Output On-The-Floor	7 Segment
41	Max. Car Calls	1-16	16
42	Safety Waiting Time	10-1000 ms	30 ms
43	Follow Motor Brake	Active Passive	Passive
44	Counter Type	M0 Counter M1 Counter ML1 & ML2 Counter Encoder	Encoder
45	Travel After JF	0-2000 ms	0
46	Photocell Time	1-5 Second	2 Second
47	KRC	Active Passive	Active
48	Encoder Factor	00.0-25.5	25.5
49	Door Position On Parking	WaitClosedDoor WaitOpenedDoor	WaitClosedDoor

**GIZMO+A3 PARAMETERS**

GIZMO+A3 PARAMETERS	P.No	Parameter Name	Value Interval	Default Values
	50	Position Reset	Active Passive	Passive
	51	Follow Overspeed Governor	Active Passive	Passive
	52	Downward Fixing		
	53	Upward Fixing		
	54	Short Floor Distance	100-180 cm	140 cm
	55	Long Floor Distance	100-180 cm	140 cm
	56	Gong Signal	Active Passive	Passive
	57	First Setup	Active Passive	Passive
	58	LCD Contrast	30-200	50
	59	UCM Test	Active Passive	Passive
	60	Intermediate Speed	Cancel -2	Cancel
	61	KAK/SAK Time	1-25 Second	7 Second
62	Default Settings			

## 6.PARAMETER DESCRIPTIONS

### 0-DiL/LANGUAGE English

**0-DiL-LANGUAGE:**Gizmo+A3 control board supports Turkish, English and Spanish languages.(Software version 1.00 product is available in one language options.)

### 1-Lift Type VVVF Control

**1-Lift Type:** The drive type of the lift can be adjusted by this parameter.

- One Speed:** Chosen for one speed roped lifts.
- Double Speed:** Chosen for double speed roped lifts.
- VVVF Control:** Chosen for lifts using speed control devices.
- Hydraulic:** Chosen for hydraulic lifts.

### 2-Control Type Complex Collective

**2-Control Type:** Lift control type can be adjusted by this parameter.

- Simple Collective:** Car and floor buttons are connected in parallel. Apart from a single call, no other calls are registered.
- Complex Collective:** Car and floor buttons are connected in parallel. Calls are kept in memory.

•**Down Collective:** Car and floor buttons are connected seperately. Car calls are collected for both directions. However, hall calls are collected during down landing of the car.

•**Full Collective:** Car requests and up and down buttons on the floors are connected seperately. Car calls and hall calls are collected in regard to the direction of movement.

•**Duplex Special:** If the number of stops is more than 9 in duplex lifts, it is used for double button collect.

**3-Number of Stops**  
16

**3-Number of Stops:** The number of stops can be adjusted by this parameter. Thus, during installation or maintenance, assigning a record for a larger number than the determined stop number is prevented. Maximum number of adjustable stops is determined by the control type and car communication methods.

**4-Num.OfBasement**  
1

**4-Number of Basements:** The number of basements can be adjusted by this parameter. If the lift type is downward collective, the floors below the programmed number of basement floors becomes upward collective.

**Note :** It is used for control types when “2-Control Type” parameter is chosen other than “Down collective”

**5-Door Type**  
F.Auto.Limitless

**5-Door Type:** This parameter adjusts open/close signal type for automatic doors.

•**Swing Door:** Used only in lifts without automatic door.

•**Car-AutoNoLimit:**Used in lifts having automatic limitless car door.

In accordance with EN 81-1/2 standard, automatic door have to be motionless in positions of emergency stop, inspection and retraction.

•**Car-AutoLimited:** Used only in lifts having automatic limited car door.

•**Full-AutoNoLimit:** Used in lifts having full automatic limitless door.

•**Full-AutoLimited:** Used in lifts having full automatic limited door.

**6-Busy Time**  
6 Second

**6-Busy Time:** Busy time can be adjusted by this parameter.

**7-LockWaitTime**  
15 Second

**7-Lock Wait Time:** At the end of the period of time determined by this parameter, if the door of the lift was not closed, control panel will be out of service. This function can be optionally cancelled.

**8-WaitOnFloor**  
5 Second

**8-Wait Time on the Floor:** During the collection of the requests, prior to departing the floor for the other request, wait time on the floor can be programmed by this parameter.

**9-FastTravelT**  
10 Second

**9-Fast Travel Time:** This parameter determines maximum allowed travel time between two neighbor stops. If this duration is exceeded, system automatically stops the car motion and is blocked.

**10-SlwTravelT**  
15 Second

**10-Slow Travel Time:** This parameter determines maximum time during travelling in slow speed, beginning from reaching at the target floor and lasts till it detects leveling bistable (JF). If this duration is exceeded, system automatically stops the car motion and is blocked.

**11-DoorOpen StayT**  
6 Second

**11-Door Open Stay Time:** If the door of the lift was not closed for any reason at the end of the time determined by this parameter, control panel becomes out of services.

**12-Parking Time**  
250 Second

**12-Parking Time:** This parameter determines wait time before the car moves to parking stop.

**13-Parking Stop**  
1

**13-Parking Stop:** If the lift remains idle in any floor for a period of time determined by “**12-Parking Time**”, it automatically moves to the floor programmed in this parameter. If you do not intend to use this parameter, it may be adjusted as “**Cancel**”.

**14-FireStop**  
1

**14-Fire Stop:** If this function is activated, when the fire contact is closed and 24V is applied to the connector numbered 816, the lift automatically directed to the fire stop determined by this parameter. If during the movement of the lift, the fire stop is on the movement direction, all calls are erasen and the lift straightforwardly directed to the fire stop. If the lift is moving on the opposite direction, it stops on the nearest available floor. All calls are erasen. It moves towards the lift stop without opening the door. On the fire stop, the lift waits its doors open and calls are not responded. In this position, the lift can only move by driver or inspection buttons. When 24V power is cut from the connector numbered 816, the lift switches back to its normal operating mode. If you do not want to use this feature, you must set this parameter as “cancel”.

**15-ArrowAnimation**  
Active

**15-Arrow Animation:** During the movement of the lift, up and down arrow signal blinks in regard to the direction of the motion.

- Active:** Arrow sign blinks.
- Passive :** Arrow sign is stable.

**16-Change PIN**

**16-Change PIN:** Gizmo+A3 control board has 5-digit password protection for protecting the parameter adjustments. When the password was entered wrong 5 times, while trying to enter into the menu PUK code is indicated. In that case, PUK code seen on the screen must be reported to our company to reset the password.

**17-Cancel PIN**

**17-Cancel PIN:** Password to enter into the menu can be reset by this parameter. The current password must be known for this.

**18-Service Reset**

**18-Reset Service Time:** This parameter is used to reset the maintenance time of the serviced lift.

**19-Service Time**

**19-Service Time:** For each day Gizmo+A3 control board operates, the programmed value of this parameter is decreased by 1. During this period, if technical personnel implements the maintenance and resets the value in “18-Service Reset” parameter, elevator keeps operating. Otherwise, from the moment the parameter decreased to 0, the operation style of the lift becomes that of the one adjusted by END OF MAINTENANCE parameter.

**20-Errors**

**20-Errors:** The most recent 20 errors can be logged here. The most recent one is the first record. When 20 error occurs and memory is filled, the first occurred error info is erased and replaced by the last error occurred.

No:12 Stop:05  
H10.LowVoltage

If ENTER key is pressed when the error list is active, erase error screen is shown. By choosing “Yes” using arrow keys, the errors can be erased.

21-Disp.Settings  
Stop:01 Disp:-1

**21-Display Setting:** This parameter can be used for setting the display for each floor. When menu is entered to program the parameters, in the lower line of the screen “Floor:01 Gos:00” is indicated. In order to change the stop number, while the stop number is blinking, reach at the stop you would like to change using UP DOWN buttons. Then press ENTER to make the display value blinking. Again by using the up and down buttons make the display setting for the given stop. To adjust another stop, press ESC key and make the given stop number blink. Repeat this process for the other stops you would like to make changes.

**22-DoorFloorSet.**  
Stop:01 Door:AB

**22-Door Floor Settings:** Automatic door adjustment for each stop can be made by this parameter. Which one of the doors from door A and door B to use in which stop can be adjusted here. When this parameter is chosen, “**Stop:**” pointing out the stop number blinks to state it is active. In this state, UP-DOWN buttons can be used to change stop number. ENTER button is pressed to specify which stop to use and parameter “**Door:**” is activated. When this parameter is blinking UP-DOWN buttons are used to choose the door. The changes are stored by pressing ENTER button.

- **A:** Door A is used.
- **B:** Door B is used.
- **AB:** Both door A and B are used.

**23-Rescue**  
Active

**23-Rescue:** This parameter specifies the rescue type in infinitely geared (with induction machine) and gearless (with synchronous machine) hydraulic lifts.

- **Active:** Rescue system is active. In case of a power cut, car is directed to the closest floor
- **Passive:** Rescue system is passive

**24-Dublex Select**  
[A] Control Panel

**24-Dublex Select:** This parameter is used to adjust panel identity of control panel during group operation. Panel identities can be adjusted as A,B,C,D,E and F. The identity of each lift panel must be different. For the records in the same distance, the priority is given to the first one in alphabetical order according to the identity of the lift. If group operation is not available, “**Simplex**” must be chosen.

**25-Call Transfer**  
Passive

**25-Transfer the Calls:** If the lift operates in group mode and outer calls are connected to a single panel, this parameter is made “**Active**” in the panel to which the outer calls are connected. In other cases it is made “**Passive**”.

**26-Phase Protect**  
Disabled

**26-Phase Protection:** This parameter can be used to activate checking of absence of phases and phase sequence.

- **Disabled:** No phase protection
- **WithPhaseSeq.:** Check phase status and sequence
- **WithoutPhaseSeq.:** Check the status of phases without phase sequence

**27-PTC**  
Active

**27-PTC :** PTC motor thermistor input can be made “**Passive**” or “**Active**” by this parameter.

- **Passive :** PTC signal can not be used
- **Active :** PTC signal can be used

**28-CarComm.  
Active**

**28-Car Serial Communication:** The connection type between the control board and car can be adjusted by this parameter. The required diagram for connections with CARCOMM serial communication board is shown in drawing numbered 11. For applications, in which car communication is specified as serial, when successful car communication is provided, “K+” is indicated on screen. If the car communication fails, “K-” is indicated on the main screen.

- Passive:** All buttons and sensors are connected by individual wires between control board and car.
- Active:** By the help of CARCOMM serial communication board, serial line connection is made between control board and car. Thus, savings from flexible cable are achieved.

**29-DoorOpenTime  
6 Second**

**29-Door Open Time:** In lifts using automatic door, this parameter adjusts the duration of time between starting of opening the door to becoming fully open position.

**30-FullAutoDoorS  
1**

**30-Full Automatic Door Selection:** In the lifts using swing door, this parameter specify the floor using automatic door, when the door of a single stop is automatic.

**31-RP Wait Time  
1500 ms**

**31-RP Waiting Time:** This parameter is displayed only for the type of lifts programmed as roped VVVF. In speed controlled panels, main contactors are desired to be released with a delay. The desired delay time can be adjusted by this parameter. In hydraulic lifts this parameter provide a delay for motor.

**32-Inspect.Move  
UpToLimitSwitch**

**32-Inspection Movement:** This parameter adjusts the movement mode in inspection mode.

- UpToLimitSwitch:** The lift stops when the breaker position is reached.
- UpToFloor:** The lift arrives at its floor even if the breaker signal is interrupted.

**33-Door Pre-Open  
Active**

**33-Door Pre-Opening:** This parameter is designed to reduce total travel time in buildings such as shopping center, hotel, hospital where the lift is used very often. When the lift approaches the target floor at a speed below 0,3m/s and arrives at the door opening zone, door contact and door lock circuits are shunted by internal shunting relays and “OPEN” command is given to the door.

When the door starts opening, the lift is still moving. Thus, because the waiting time to open the door is reduced, total travel time decreases. To specify door opening zone, “**38-Pre-OpenDist.**” parameter must be programmed to specify the distance in mm to start opening door before the door reaches at the floor. Door early opening process can be used for both roped and hydraulic lifts.

- Passive:** Door early opening is passive
- Active:** Door early opening is active

Motion of the car during the door is open for door early opening process is allowed only inside the door opening zone and when the lift speed is below 0.15 m/s under the control of door shunting circuit placed on the Gizmo+A3.

**34-Star-Delta**  
5 Second

**34-Star Delta Delay:** This parameter can only be displayed for lifts which is programmed in hydraulic mode of operation. During the starting of the motor, the time duration of operation in star connection can be adjusted by this parameter.

**35-ValveTime**  
5 Second

**35-Motor Valve Delay:** This parameter can be displayed in hydraulic lifts. Depending also on the brand of the hydraulic unit, in order to be able to obtain a comfortable starting, in regard to the specifications of the manufacturer, the time delay for opening the valves after the motor started operating in delta connection can be adjusted by this parameter.

**36-Re-Leveling**  
Active

**36-Re-leveling:** This parameter can only be used in VVVF lifts with well learning and hydraulic lifts. If the lift while idling in a floor slides above or below the floor level for any reason, control board detects this situation and brings the lift to exact floor level. When this parameter is active, if sliding occurs during the door is closed, car is leveled into the floor. If the sliding occurs during the door closed, internal shunting circuit is closed and the lift movement is made possible while the door is open. This function is used very often particularly in hoists. For example, in a hoist, loading the goods to the lift may make it slide back a little down the floor level. In that case, the lift moves to the exact floor level while its door open. By making this parameter active, floor adjustment can also be made from the interior of the car.

•**Active:** Releveling is active

•**Passive:** Floor adjustment from the interior of the car and leveling is not made.

**37-First Stop**  
1

**37-First Stop:** This parameter is used only in group operation mode. If there is a difference between number of stops in the group of lifts, first floor adjustment is made by this parameter for the lifts with different number of stops. During making this adjustment, number of stops of the lifts in the group must be adjusted the same. For example in a 10-stop duplex system, if the lift A is not serving to the lowest floor and lift B serves this one: Both of the lifts are adjusted to 10 stops, first stop for the lift A is adjusted to 2.

**38-Pre-OpenDist.**  
**90**

**38-Pre-Open Distance:** For the lifts having early door opening feature, this parameter is used to adjust the distance in mm to open the automatic door prior to reaching to the floor.

**39-DispAnimation**  
**Active**

**39-Display Animation:** When this parameter is active, in each change of floors, 7 segment display shows the current floor and the target floor alternately.

- **Active:**Floor animation is active
- **Passive:**Floor animation is passive

**40-DisplayOutput**  
**7 Segment**

**40-Display Output:** Besides outputting classical 7 segment display, Gizmo+A3 control board can also output Gray, Binary and output-at-each-floor. Thus, system operation can be possible without requiring any converter boards for different button models.

- **7 Segment:** Output for 7 Segment display
- **Gray :** Display output is in Gray code
- **Binary:** Display output is in Binary code
- **Output at each floor:** One segment of the display is active for each floor. This option can only be active if “03-NumberOfStops” parameter is adjusted below 10.

**41-Max.CarCalls**  
**16**

**41-Max.CarCalls:** This parameter determines maximum number of calls that can be given from the interior of the car. After exceeding this number, the calls given from the interior of the car is denied.

**42-SafetyWaiting**  
**16 Second**

**42-Safety Waiting Time:** This parameter is used to adjust delay time for the lift to start moving after door contact (130) and door lock (140) safety signals are received.

**43-FollowM.Brake**  
**Passive**

**43-Follow Motor Brake:** If this parameter is activated, motor brake watching contacts have to be connected. When it is in “Passive” mode, in gearless machines A3 does not detect any error in case it falls out of system. Because of that, it has to be ensured that it is not made passive. Our company will not be responsible or liable from cancellation of this parameter.

**NOTE:** If brake watch error is given, keep “ESC” button pressed for 30 second.

- **Passive :** Motor brake contact is not watched. Choosing this option should be strictly avoided in A3 systems.
- **Active :** Motor brake contact is watched

**44.Counter Type  
Encoder**

**44-Counter Type:** This parameter is used to program floor selection system used for lift position information.

- [M0] Counter:** M0 counter
- [M1] Counter:** M1 counter
- [ML1] & [ML2]:** Chosen for lifts employing speed control device and for hydraulic lifts.
- Encoder:** Chosen for lifts using well learning and complying with A3 standard.

**45.TravelAfterJF  
10 Second**

**45-Travel After JF:** This parameter is used to increase stopping distance when the magnet distance is insufficient in low speed lifts.

**46-PhotocellTime  
10 Second**

**46-Photocell Time:** This parameter is used to adjust delay time for closing the door after the automatic door is opened and photocell signal is interrupted.

**47-KRC  
Passive**

**47-KRC:** In terms of EN81-1/2 regulations, the positions of the connectors used in control board must be controlled by Gizmo+A3. But for countries not applying rules of Europe standards, KRC signal can be cancelled. The using option of KRC signal can be adjusted by this parameter.

- Active:**KRC control is active
- Passive:**KRC control is passive

**WARNING ! :** For compliance with EN81-1/2 directives, it HAS TO be adjusted as “Active”.

**48-EncoderFactor  
25.0**

**48-Encoder Factor:** This parameter must be calculated in mm for precise leveling considering lift speed, encoder pulse number and motor speed. The calculation is made in the following way;

$$Encoder Factor = \frac{\frac{Motor Speed \times Encoder Pulse}{60}}{Lift Speed \times 1000}$$

$$Encoder Factor = \frac{\frac{1500 \times 1024}{60}}{1.5 \times 1000} = 17$$

**49-DoorOnParking  
WaitClosedDoor**

**49-Automatic Door Parking Position:** In the lifts having automatic door, this parameter is used to define the position of the door while waiting idle in parking stop.

- **WaitClosedDoor:** The door is closed while the lift is idle on a floor
- **WaitOpenedDoor:** The door is open while the lift is idle on a floor

**50-PositionReset  
Passive**

**50-Position Reset:** In systems operating in counter type, the last stop the car is situated is kept in memory in case of power cuts. However, in some special cases, when the power is restored, a position reset may be requested. For example, in lifts with battery-powered rescuer systems, this parameter can be activated to provide position reset. For the position reset process, the car moves to search for the position of 817 bottom final limit switch.

- **Passive:** Do not do the position reset
- **Active:** Do the position reset

**51-FollowOverSpe  
Active**

**51-Follow Overspeed Governor:** If this parameter is activated, regulator watching contacts have to be connected. When it is in “**Passive**” mode, A3 does not detect any error in case it falls out of system. Because of that, it has to be ensured that it is not made passive. Our company will not be responsible or liable from cancellation of this parameter. In “**Active**” mode, the lift does not start its movement prior to receiving regulator coil pulled signal. So, during activation, verify that RGA signal is active.

- **Passive:** Regulator status is not watched. Choosing this option should be strictly avoided in A3 systems.
- **Active:** Regulator status is watched

**52-DOWN Fixing**

**52-DOWN Fixing:** For the lifts the “**44-Counter Type**” was programmed as encoder, this parameter can be used to enter floor alignment value in mm for each floor in down direction. If the car is situated above the floor level “-” value is entered, otherwise if it is situated below the floor, “+” value is entered.

**53-UP Fixing**

**53-UP Fixing:** For the lifts the “**44-Counter Type**” was programmed as encoder, this parameter can be used to enter floor alignment value in mm for each floor in upward direction. If the car is situated above the floor level “-” value is entered, otherwise if it is situated below the floor, “+” value is entered.

**56-Gong Signal**  
Active

**56-Gong Signal:** In the case of using CARCOMM car-top serial communication board, it is used to activate GONG output on the CARCOMM board. When the internal inspection board placed on the CARCOMM board arrives at its target floor, it plays gong sound.

- Passive:** GONG sound is not played
- Aktive:** GONG sound is played

**57-First Setup**  
Passive

**57-First Installation:** In the lifts using well learning, this parameter must be activated for well learning process. After the well learning process completes, it must be taken back to “Passive” mode.

- Passive:** Learning well is completed and will operate normally.
- Active:** Learning well will be executed.

**58-LCD Contrast**  
100

**58-LCD Contrast:** This value is used to adjust contrast of LCD screen located on Gizmo+A3 control board.

**59-UCM Test**  
Passive

**59-UCM Test:** The operating condition of the lift leveling system can be tested by this parameter.

- Passive:** Leveling testing is not made.
- Active:** Leveling test is made.

**61-KAK/SAK Time**  
7 Second

**61-KAK/SAK Time:** The activation times of grid contactor and rescuer contactors can be adjusted by this parameter.

**62-DefaultSett.**

**62-Restore Factory Default Settings :** If ENTER key is pressed when this parameter was chosen, factory default values are restored.

## **7.ERROR CODES**

**H1.Stop Error**  
d01→h-- 24V

**H1.Stop Error:** Stop circuit does not conduct. When this fault occurs the lift is instantly halted and all calls are erased. When stop circuit is short circuited, the lift returns to its normal operation.

**H2.DoorOpened**  
d01→h-- 24V

**H2.DoorOpened:** Shown in cases where the elevator doors not closed. There may be a situation that prevents the door closing or disconnect the safety circuit.

**H3.PTC Error**  
d01→h-- 24V

**H3.PTC Error:** Motor's temperature is continuously monitored by a temperature sensor attached to the windings of the lift's motor. If the temperature limit value is exceeded while the lift is moving, the control system halts at the nearest available floor in moving direction and existing records are cancelled. New calls are not accepted until the temperature decreases below the limit value.

**H4.KRC Error**  
d01→h-- 24V

**H4.KRC Error:** A signal terminal connected through normally closed contacts of contactors is connected to KRC. Therefore, in case of any fault such as sticking of contactor terminals, this fault occurs in control board and no new record is accepted.

**H5.OverLoad**  
d01→h-- 24V

**H5.Over Load Error:** If the weight of the car is more than allowed, over load contact is closed and 24V comes across the connector numbered 804. Control board does not let the motion of the lift. Door of the lift is kept open to await the decrease of the load inside car.

**H6.818 NoLimit**  
d01→h-- 24V

**H6.818 Limit is not present:** No signal is received from 818 top final limit bistable switch. Control board does not let the motion of the lift in this condition.

**H7.817 NoLimit**  
d01→h-- 24V

**H7.817 Limit is not present:** No signal is received from 817 bottom final switch. Control board does not let the motion of the lift in this condition.

**H8.LowSpeedTime**  
d01→h-- 24V

**H8.LowSpeedTime:** It indicates the maximum allowed time for the lift to move in low speed. If the lift can not reach to target floor in this time, the lift is instantly stopped. It is automatically reset after a defined period of time.

**H9.HighSpeedTime**  
d01→h-- 24V

**H9.HighSpeedTime:** It indicates the maximum allowed time for the lift to move from one floor to the other at high speed. If the lift can not reach to the next floor in this time, the lift is instantly stopped. High speed error is automatically reset after a defined period of time.

**H19.LowVoltage**  
d01→h-- 24V

**H19.LowVoltage:** Low voltage warning is displayed when the supply voltage of GIZMO+A3 control board is below 17V.

**[R] Phase Failure**  
d01→h-- 24V

**[R] Phase Failure:** R phase can not be detected by control board.

**[S] Phase Failure**  
d01→h-- 24V

**[S] Phase Failure:** S phase can not be detected by control board.

**[T] Phase Failure**  
d01→h-- 24V

**[T] Phase Failure:** T phase can not be detected by control board.

**NoProperLocation**  
d01→h-- 24V

**No Proper Location:** During the well learning process, if 817 and 818 signals (final switches) are simultaneously passive, this message is displayed.

**Encoder Error**  
d01→h-- 24V

**Encoder Fault:** This message is displayed in case something unexpected happens in encoder connections or received signals.

**OverSpeedActive**  
d01→h-- 24V

**Regulator coil did not break loose:** It indicates regulator coil remained pulled-in. After checking the regulator, press ESC key for 5 seconds to reset this error.

**ReverseDirection**  
d01→h-- 24V

**Motion in reverse direction:** The lift moves in the opposite of the commanded direction. Replace ML1 and ML2 magnetic switches.

**ML ShortCircuit**  
d01→h-- 24V

**ML Short Circuit Error:** Signals received from ML1 or ML2 magnetic switches do not change.

## **8.WELL LEARNING PROCEDURE**

Owing to its well learning feature incorporating advanced encoder, Gizmo+A3 control board simplifies the installation of the lift. The following steps should be followed for well learning with encoder.

### ***1.Step***

**44-Counter Type Encoder**

**44-Counter Type** parameter should be programmed as **Encoder**

### ***2. Step***

**48-Encoder Factor  
25.5**

**2.Encoder Factor:** This parameter must be calculated in mm for precise leveling considering the lift speed, encoder pulse number and motor speed in rpm. The calculation is made by;

$$Encoder Factor = \frac{\frac{Motor Speed \times Encoder Pulse}{60}}{Lift Speed \times 1000}$$

$$Encoder Factor = \frac{\frac{1500 \times 1024}{60}}{1.5 \times 1000} = 17$$

### ***3. Step***

**33-Door Pre-Open Active**

**33-Door Pre-Open** parameter must be programmed **Active**.

### ***4. Step***

**36-Re-Leveling Active**

**36-Re-Leveling** parameter must be programmed **Active** for the lift to be able to stop at exact floor level.

### ***5. Step***

**03-NumberOfStops  
10**

**3- NumberOfStops** must be programmed by **Stop Number** parameter.

### ***6. Step***

**57-First Setup Active**

**57-First Setup** parameter must be programmed **Active**. When well learning action is completed it must be programmed **Passive**.

**7. Step**

Well Learning  
d01 65534 0.00

After programming the parameter settings as described in the first 5 steps, menu must be exited. Prior to initiating well learning procedure, the message on the left is displayed.

**8. Step**

Inspection Well  
d01 62123 0.10

Put the lift from the well mode to inspection mode. Give up/down commands while running in inspection mode and observe that encoder pulse and lift speed values are counting properly. If they are not changing or changes in reverse direction, check your encoder connections.

**9. Step**

EncoderReset  
d05 65534 0.10

Keep ESC key pressed for 3 seconds. If 817 and 818 signals are active, well learning procedure initiates and lift starts to move down. “**EncoderReset**” message is displayed, it moves in high speed to search for the position of 817 bottom final limit switch and stops in the lowest floor.

**10. Step**

UP Dir.Learning  
d10 65534 0.15

After completing the encoder reset procedure, “**UP Dir. Learning**” message is displayed and the lift moves up to record the positions of number of stops indicated in **03-NumberofStops** parameter. It decelerates to slow speed prior to reaching the top floor and stops on the floor level. Its speed during deceleration must be at most 0.15.

**11. Step**

DOWN Dir.Learning  
d10 65534 0.15

Following the up recognition is complete, “**DOWN Dir.Learning**” message is displayed on the screen and the lift moves until 817 bottom limit switch signal is interrupted. Meanwhile, it records stop positions. The movement is ended when ML1 and ML2 signals are active.

**12. Step**

UP Dir. Learning  
d10 65534 0.15

Following the down recognition, “**UP Dir.Learning**” message is displayed second time and in the upper direction the lift detects and stores floor alignments by accelerating and decelerating at each floor. After well learning procedure is completed **57-First Setup** parameter must be adjusted **Passive**.

After the well learning procedure is completed, for the floors on which the car does not stop at exact alignment, **52-DOWN Fixing** and **53-UP Fixing** parameters can be used to make floor adjustment for each floor in mm. If the car is below the floor alignment “+”, if it is over floor alignment “-“ value must be input. Floor adjustment corrections can be made at most +/- 125mm. In case there is higher difference, the positions of 30cm strip magnets should be checked and well learning procedure must be repeated.

Another advanced feature of Gizmo+A3 control board during well learning function is that floor adjustment can be made on the interior of the car. These steps should be followed for floor adjustment on the interior of the car.

**1.Step**

Inside of the car, keep pressed the call button of which the car is situated.

**2.Step**

Push and release the door opening button for a short time for 5 times. When the car lamp turns off, keep door-opening button pressed.

**3.Step**

Release the call button, execute the down correction using the call button of the lowest floor and execute upward correction by one upper floor of the lowest floor and bring the car in floor level. When the car is in exact floor alignment, release door opening button. The adjusted value is stored for the floor car is situated.

**9. FREQUENTLY ASKED QUESTIONS (FAQ)**

• *No movement during inspection.*

When the system was taken to inspection using inspection power switch, signal numbered 869 must turn off. Control card displays whether the lift was taken to inspection from the well or from the panel. Inspection movement buttons turn on signals numbered 500 and 501. If they are not turned on, cabin connections must be checked. When the lift has been taken to inspection, safety circuit is cut off. Safety circuit closes its loop through inspection movement buttons. When the buttons are pressed, check that safety circuit closes its loop. Limit switches should not prevent the movement. Thereby, 817 (KSR1) and 818 (KSR2) cutting signals in the card must be on. Else, limit power switches must be checked. Make sure that 120 (Stop), 130 (Door contact), 140 (Lock) circuits conduct. (All signals on the control card must be on).

• *The lift stops without decelerating.*

If the same problem is present in every stop, probably precision stop magnetic switch is damaged. When the lift starts decelerating, signal 142 in the card must be on. If the problem exists in only one stop, the magnets and the distance between magnets and magnetic switches must be checked.

• *The lift hits above.*

Check that upper limit switch 818 (KSR2) circuit functions well. In last stop's deceleration level 818 signal in the card must be off. Else, tubes and magnets must be checked. Floor stopping magnetic 142 may be stucked. Signal 142 must be off in precise floor levels. If not, check the magnetic switches and magnets.

• *The lift hits below.*

Check that lower limit switch 817 (KSR1) circuit functions well. In the last stop's deceleration level, 817 signal in the card must be off. Else, tubes and magnets must be checked. Floor stopping magnetic 142 may be stucked. Signal 142 must be off in precise floor levels. Else, check the magnetic switches and magnets.

• *When one button is pressed in the card, all recorded signals turn on.*

Probably, the common terminal of signal lamps are connected to each other, but 100 (+24V) is not connected to the connector. Thereby, buttons loop through common terminal.

- *Position count gets mixed.*

Check that number of stops and digital settings are adjusted correctly. Make sure that 817 breaker circuit in the first stop and 818 breaker circuit disconnect. By monitoring M1 or M0 signal during movement, check if any faulted signal is generated. M1 or M0 must be blinking at least once in each stop. If any problem is observed, magnetic switch may be too far from the magnets, it may be damaged or a magnetisation in the rails may have occurred.

- *M1 signal is blinking but the card does not count the stops.*

The stops can only be counted correctly, in case 817,818 limit breakers close their circuits. Therefore, 817, 818 limit breaker signals are supposed to be on, except for upper and lower limits. Keep in mind that when the lift is moved by switching the contactors, the counting can not be done as the card does not know which direction the lift moves.

## **10. IMPORTANT CONSIDERATIONS IN INSTALLATION OF THE PRODUCT**

Panel manufacturer firm producing GIZMO+A3 control card and lift control panel must have sufficient knowledge and experience on EN-81 standard, other norms, regulations and directives dealing with this subject. In case the instructions given here have not been complied, EEM Imp. Exp. Trade Co. does not assume responsibility in appropriateness of the produced panel to the EN-81 standards. Installation of Gizmo+A3 control card and double speed lift control panel is shown in schematics. The important considerations throughout the manufacturing of control panel are explained below item by item.

- A minimum space of 9mm must exist between Gizmo+A3 control card and control panel surface. Gizmo+A3 control card must be fixed on 4 holes in each corner.
- For EMC compliance, control card must be laid away from the contactors.
- 24VDC signal cables and other cables must be placed separately.
- Some conductive particles such as iron powder produced during installation of all electronic cards into the panel must be carefully cleansed. Else, these particles may cause damage by falling over the control card or other equipment during transport or installation.
- Connections between Gizmo+A3 control card and connector cards must be implemented as shown in the schematics. To avoid any mistake, connector names are written in large typesize.
- The contactors used for the lifts having AC motor must be AC3 class as described in EN60947 and they must be rated in regards to motor power. The connections must be done as shown in the schematics.
- The auxiliary contacts placed over the contactors must comply with EN60947 standard and it must be assured that contactors open and close at the same time with power contacts.
- It must be assured that damping circuits (series resistor-capacitor) are connected to contactor coil terminals.
- As shown in the schematics, a 20mA leakage current fuse must be used to cut supply voltage of safety contacts in case of a leakage from safety contacts to chassis.
- Bridge diode connections of brake and pump must be done as shown in the schematics and they must be electrically isolated.
- For long and healthy operation, brake coil output contacts and RU1 and RU2 contacts are needed to be power contacts.
- Control panel inspection switch connection must be done as shown in the schematics. By means of this connection, when the inspection switch over the cabin is turned ON, inspection buttons on the control panel can not move the lift.
- Cable contactors, connected to KRC connector that is used to check whether contactors operate well must be serially connected through normally closed contacts. If possible, these normally closed contacts must be auxiliary contacts fixed on contactor, instead of additional auxiliary blocks.
- Following the completion of control panel production, manufacturer must test it by checking all connections.

## **11. IMPORTANT CONSIDERATIONS IN CONNECTION OF CONTROL PANEL TO LIFT SYSTEM AND MAKING THE SYSTEM OPERATIONAL**

The information given here only aims a general description and recommendation. EEM Imp. Exp. Trade Co. in any circumstance does not assume responsibility for any damages and accidents caused by the descriptions given here. The product must only be installed and operated by qualified, trained personnel who have knowledge on EN-81 standard and practices. The operation of the lift must be carried out only after assuring all precautions.

### **11.1- Important Considerations in Connecting Control Panel to Lift System**

- The connections between control panel and motor, cabin and well must be carefully implemented in accordance with the schematics.
- Contactor, automatic fuse, motor protection switch and thermic relay must be rated in accordance with the motor power.
- Neutral and ground cables must be installed separately and panel chassis must be connected to the ground properly.
- The lift must have all the stopping mechanisms mentioned in EN-81 standard and these mechanisms' contacts must be connected to control panel carefully. These connections to safety contacts must be done in accordance with the schematics properly. All safety contacts used must be in compliance with EN60947 standards.

### **11.2- Important Considerations on Preparing the System Become Operational**

- Check that the connections between control panel and lift system are consistent with the schematics.
- Using a measuring device check whether any short-circuit exist between connections.
- Turn ON the inspection switch in control panel.
- Turn ON motor protection switch and power the panel.
- Check that 02-Out of service led in Gizmo+A3 control card and out of service leds on floor buttons are operating.
- By checking the leds on control card (which are labelled 5V and 100) make sure that supply voltages exist. Measuring between 100 and 1000 connectors, a voltage should read between 20...26VDC.
- Make sure that all safety contacts are connected in consistence with the schematics and make sure they operate correctly. By checking the leds on control card (120,130,140), make sure that safety contact inputs are active.
- In order to be able to move the cabin in both ways, temporarily connect lower and upper stopper bistable switch inputs with the connector numbered 100. In that case, as the lower and upper stopper bistable switches will not be able to perform their duties, give extreme care during working in the lowest and highest floors.
- As the control panel inspection switch is ON, cabin travels only in low speed. Make sure that low speed coil of the motor is correctly connected, by moving the cabin using up and down buttons placed on control panel. If the pressed button and the travel direction of the cabin do not match, exchange the connection of any two of the U2,V2,W2 terminals on the motor between low speed coil and control panel.
- While the cabin is travelling, measure the voltages between 2001
- Afterwards, move the cabin in one of the interval floors and turn ON the inspection switch on the cabin. In that case, cabin can not be conveyed using inspection buttons on the control panel.
- Move the cabin to the lowest stop. Place the magnets of gray code, floor stopper and upper and lower limit stopper bistable switches in consistent with the magnets.
- By monitoring stop numbers in LCD screen or in display placed over the control card, check that the ordering has been done correctly.

- Remove the connecting link between lower and upper stopper bistable switch inputs applied through the connector numbered 100.
- Place the cabin in one of the interval floors and turn OFF the over-cabin inspection switch.
- Turn OFF the control panel inspection switch. Therefore, lift returns to its normal operation state and OUT OF SERVICE leds on floor buttons turn off.
- Give a call to the lift and make sure it travels in expected direction in high speed. If the lift does not travel in the expected direction, reverse only two terminals (U1,V1,W1) of motor's connection between high speed coil and control panel.
- In each floor, give calls for both directions and check that the cabin stops in exact floor level. If needed, re-arrange the positions of stopper bistable switch magnets.



In normal operation state of the lift, it must be assured that lower and upper stopper bistable switch inputs are not linked through the connector numbered 100.



Check that all safety contacts operate correctly before the lift returns to its normal operating mode.



Never link safety circuits (120 emergency stopping, 130 door, 140 lock)

## **12. MAINTENANCE AND CLEANING OF GIZMO+A3 CONTROL CARD**

- It does not need periodical maintenance.
- If any faulted operation is detected, it must be sent to the manufacturer firm for test and repair.
- It must be kept free of water and any other kind of liquids.
- If needed, the dust over the control card must be cleaned using low pressure air.

## **13. SAFETY NOTICES**

Averting any accident risks in a lift without having user risk (in a lift having security measures such as automatic door complying with standards and over-load system) is in responsibility of subsidiary firms and installation and maintenance firms. Some fundamental security subjects concerned with lift control system are touched on below.



For the lift system to be fully complied with EN81 standards, control panel of control card and electrical connections must be appropriate. Our firm guarantees that control card is complied to the standards. However, installer firm is responsible for inner and outer connections of control panel and other electrical connections.



Safety circuit of Gizmo+A3control card operates from 220VAC. Motor start-up contactors are directly supplied from the return terminal of safety circuit. Therefore, in safety circuit, unintentional operations besides control are prevented.



The terminal numbered 11 in Gizmo+A3 control card **HAVE TO** be connected to the return terminal of safety circuit (140-lock return). Otherwise, risks grow. However, if control card does not sense the return terminal of safety circuit, it halts the lift instantly.



Do not connect safety circuit through any relays or contacts in any way directly or indirectly except for security arrangements.



Hide the connectors that you attached door contact and lock circuits to the door apertures by avoiding any contact to door chassis. Keep in mind that during the building cleaning water may drain through the cabin. Therefore, it may be necessary to implement safety connections in isolated channels. Otherwise, they must be isolated with isolation bands.



Door frames must be assured to be connected to the ground bus bar. In case the grounding has not been installed, there is a risk that safety circuit is indirectly linked through door chassis.



It must be assured that the contactors are not released manually. In that case, safety circuits and control card can not prohibit the lift's movement.



When the 24 VAC signal fuse is damaged or it permanently remained on, it must be ensured it is not shunted. This may damage Gizmo+A3 control card.



To make sure that cabin lamp stays on when thermic relay in the panel is switched off, supply voltage of cabin lamp (1F) must be directly connected to the electric panel on machine room.



The safety circuit may lose its functionality by subjecting to wear and tear and exposing to dust, dirt and oil. In periodical maintenances remember to check functions of door contacts and locks. Consider important that all these precautions are necessary to operate our lifts safely and therefore reduce any accident risk.

## **14. DRAWINGS and DIAGRAMS**

Control panel, car and shaft connection and drawings of GIZMO+A3 control board listed below.

<b>Drawing No</b>	<b>Page</b>	<b>Description</b>
1A	1	Single Speed Control Panel Connection Draw
1B	1	Double Speed Control Panel Connection Draw
2A	2	Akiş Hydraulic Control Panel Connection Draw
2B	3	KLEEMANN Hydraulic Control Panel Connection Draw
2C	4	Morris Hydraulic Control Panel Connection Draw
3A	5	LG IV5 Speed Controlled Control Panel Connection Draw
3B	6	LG IV5 Speed Controlled A3 Control Panel Connection Draw
3C	7	LG IV5 Speed Controlled Gearless A3 Control Panel with UPS Rescuer Connection Draw
4	8	DELTA VL Speed Controlled A3 Control Panel Connection Draw with UPS Rescuer
5	9	MEIDEN Speed Controlled A3 Control Panel Connection Draw with UPS Rescuer
6	11	VACON NXP Speed Controlled A3 Control Panel Connection Draw with UPS Rescuer
7	11	FUJI Speed Controlled A3 Control Panel Connection Draw with UPS Rescuer
8	12	ADRIVE Speed Controlled A3 Control Panel Connection Draw with UPS Rescuer
9	13	CARCOMM Car Communication Board and Inspection Board Connection Draw
10	14	Parallel Car Connection
11	15	Safety Circuit Connection
12	16	Door Control Board Connection Draw
13	17	Floor installation, Brake and Motor thermistor connection
14	18	M1 counter magnet order for double speed and VVVF speed controlled roped lift
15	19	M0 counter magnet order for double speed and VVVF speed controlled roped lift
16	20	ML1 & ML2 Magnet order for roped and hydraulic lift
17	21	Shaft learning magnet order for roped and hydraulic lift
18	22	SONIC Announcement Board connection draw with GIZMO+A3 and CARCOMM
19	23	Set working parameter on SONIC announcement board
20	24	Encoder Connections
21	25	GIZMO+A3 TERMINAL board flexible cable connection
22	26	TERMINAL connection board symbols

NOTE: If your grounding resistor equals or less than 5 Ohm, there is no need to use the isolation transformer.  
 In this case, leakage current relay inputs can be connected to S and Mp terminals directly which are placed on outputs of motor protection switch.  
 There is no need to use grounding the primary or secondary terminals of transformer because isolation transformer wasn't used.  
 But the body of transformer must be grounded.  
 Bobbins of these contactors must be AC-3 class 220VAC bobbin. RC filters must be connected to the bobbins of contactors certainly.

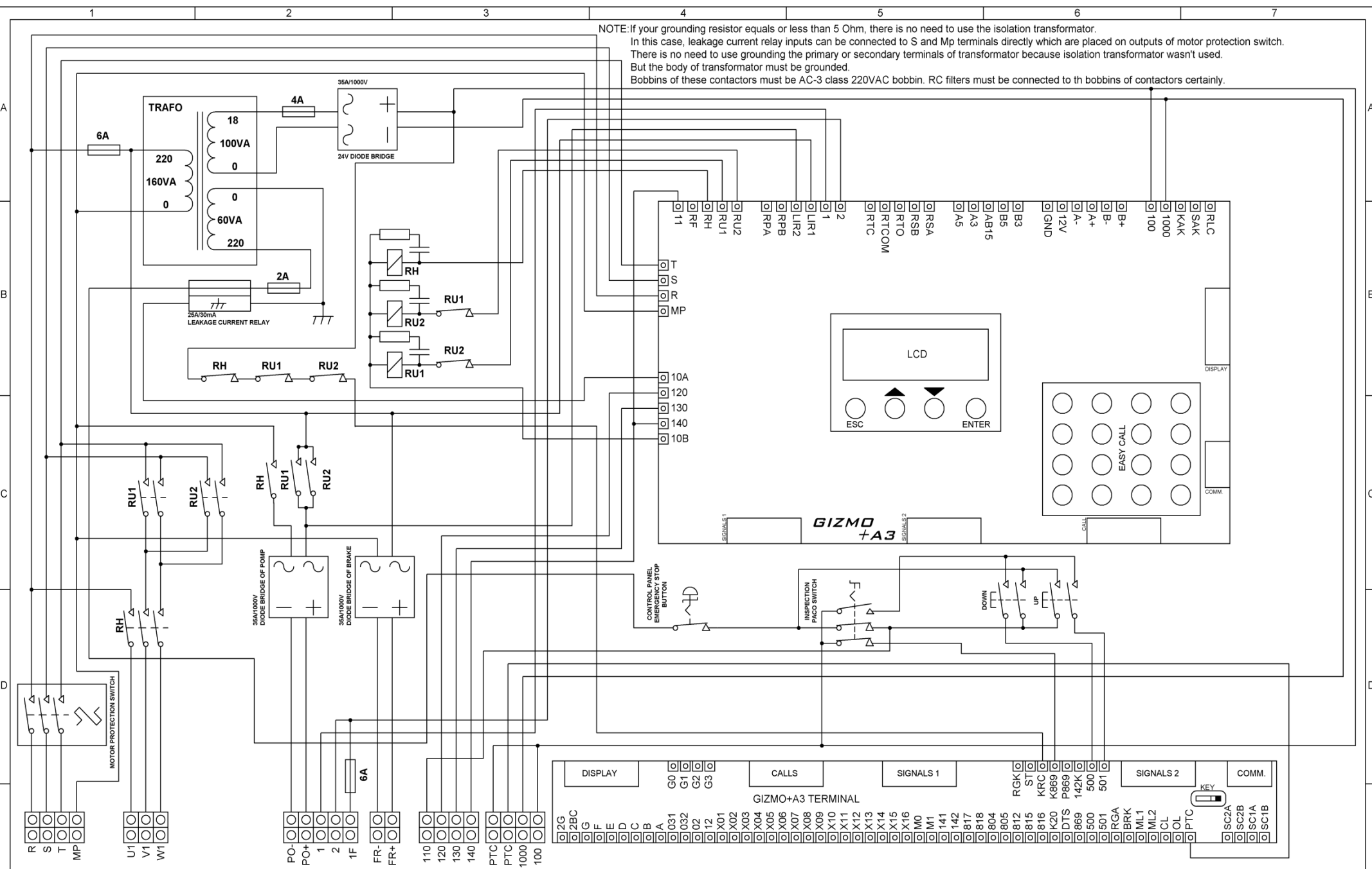

EEM Imp. Exp. Trade Co.  
 Lift Control System

Project Name Gizmo+A3 Lift Control System

Drawing Name Single Speed Control Panel Connection Draw

Description

Version 2.00

Date 05.07.2015

Drawing No 1A

Page 1



Drawer HU

Control BA

Tel: +90.332 346 46 56 - 66  
 Fax: +90.332 346 46 76

www.eem.com.tr

NOTE: If your grounding resistor equals or less than 5 Ohm, there is no need to use the isolation transformer.  
 In this case, leakage current relay inputs can be connected to S and Mp terminals directly which are placed on outputs of motor protection switch.  
 There is no need to use grounding the primary or secondary terminals of transformer because isolation transformer wasn't used.  
 But the body of transformer must be grounded.  
 Bobbins of these contactors must be AC-3 class 220VAC bobbin. RC filters must be connected to th bobbins of contactors certainly.

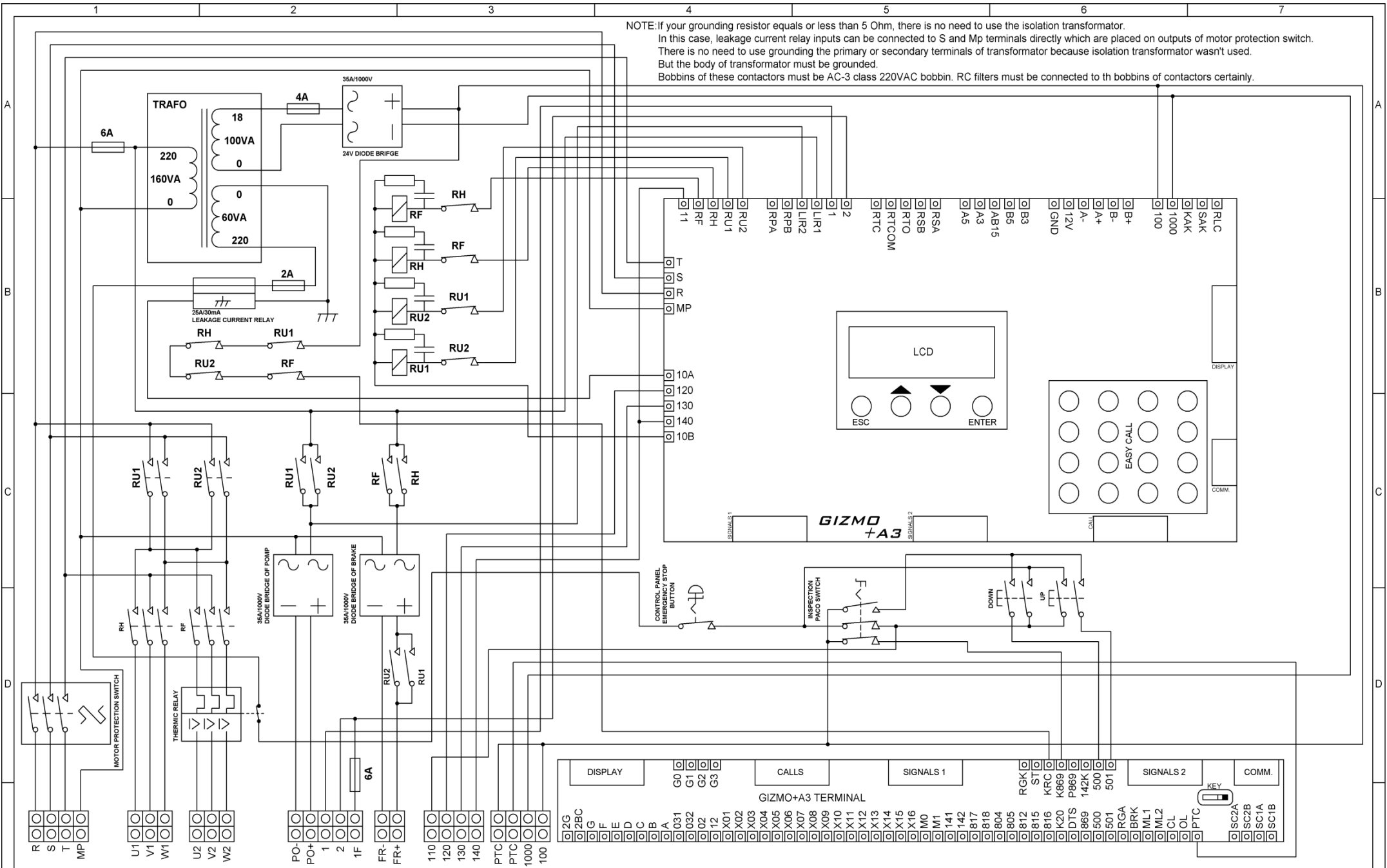

**eem** EEM Imp. Exp. Trade Co.  
 Lift Control System  
 Tel: +90.332 346 46 56 - 66  
 Fax: +90.332 346 46 76 www.eem.com.tr

Project Name Gizmo+A3 Lift Control System  
 Drawing Name Double Speed Control Panel Connection Draw  
 Description

**CE** Drawer HU  
 Control BA  
 Version 2.00 Date 05.07.2015 Drawing No 1B Page 1

NOTE: If your grounding resistor equals or less than 5 Ohm, there is no need to use the isolation transformer.  
 In this case, leakage current relay inputs can be connected to S and Mp terminals directly which are placed on outputs of motor protection switch.  
 There is no need to use grounding the primary or secondary terminals of transformer because isolation transformer wasn't used.  
 But the body of transformer must be grounded. Bobbins of these contactors must be AC-3 class 220VAC bobbin.  
 RC filters must be connected to th bobbins of contactors certainly.

V10: Valve Common Terminal  
 VA: UP-Slow Valve  
 VB: UP-Fast Valve  
 VC: DOWN-Fast Valve  
 VD: DOWN-Slow Valve

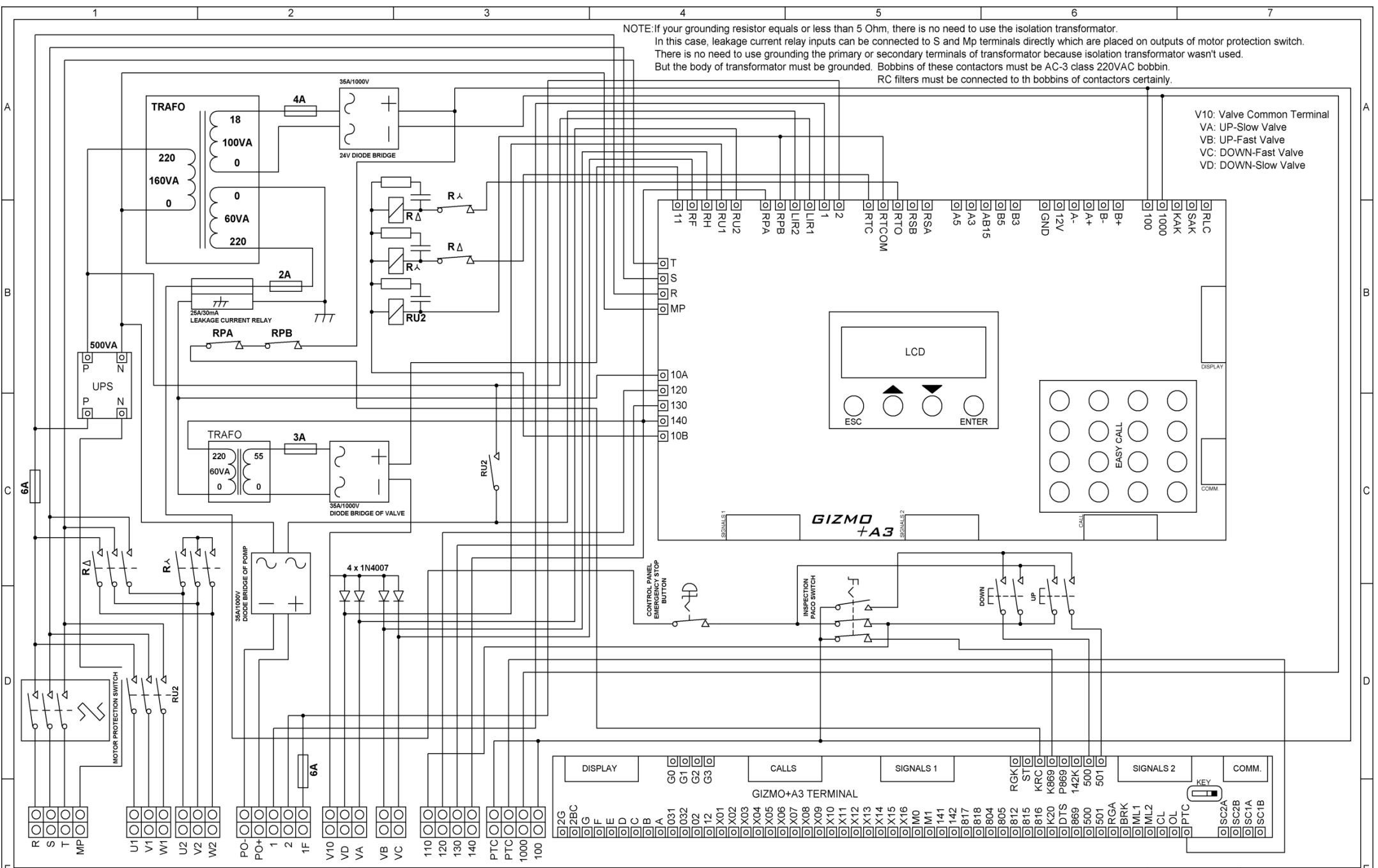

EEM Imp. Exp. Trade Co.  
 Lift Control System

Project Name Gizmo+A3 Lift Control System  
 Drawing Name Akiş Hydraulic Control Panel Connection Draw



Drawer HU  
 Control BA

Tel: +90.332 346 46 56 - 66  
 Fax: +90.332 346 46 76

www.eem.com.tr

Description Version 2.00 Date 05.07.2015 Drawing No 2A Page 2

NOTE: If your grounding resistor equals or less than 5 Ohm, there is no need to use the isolation transformer.  
 In this case, leakage current relay inputs can be connected to S and Mp terminals directly which are placed on outputs of motor protection switch.  
 There is no need to use grounding the primary or secondary terminals of transformer because isolation transformer wasn't used.  
 But the body of transformer must be grounded. Bobbins of these contactors must be AC-3 class 220VAC bobbin.  
 RC filters must be connected to th bobbins of contactors certainly.

V10: Valve Common Terminal  
 VD: DOWN-Slow valve  
 VA: UP-Slow valve  
 VB: UP-Fast valve  
 VC: DOWN-Fast valve

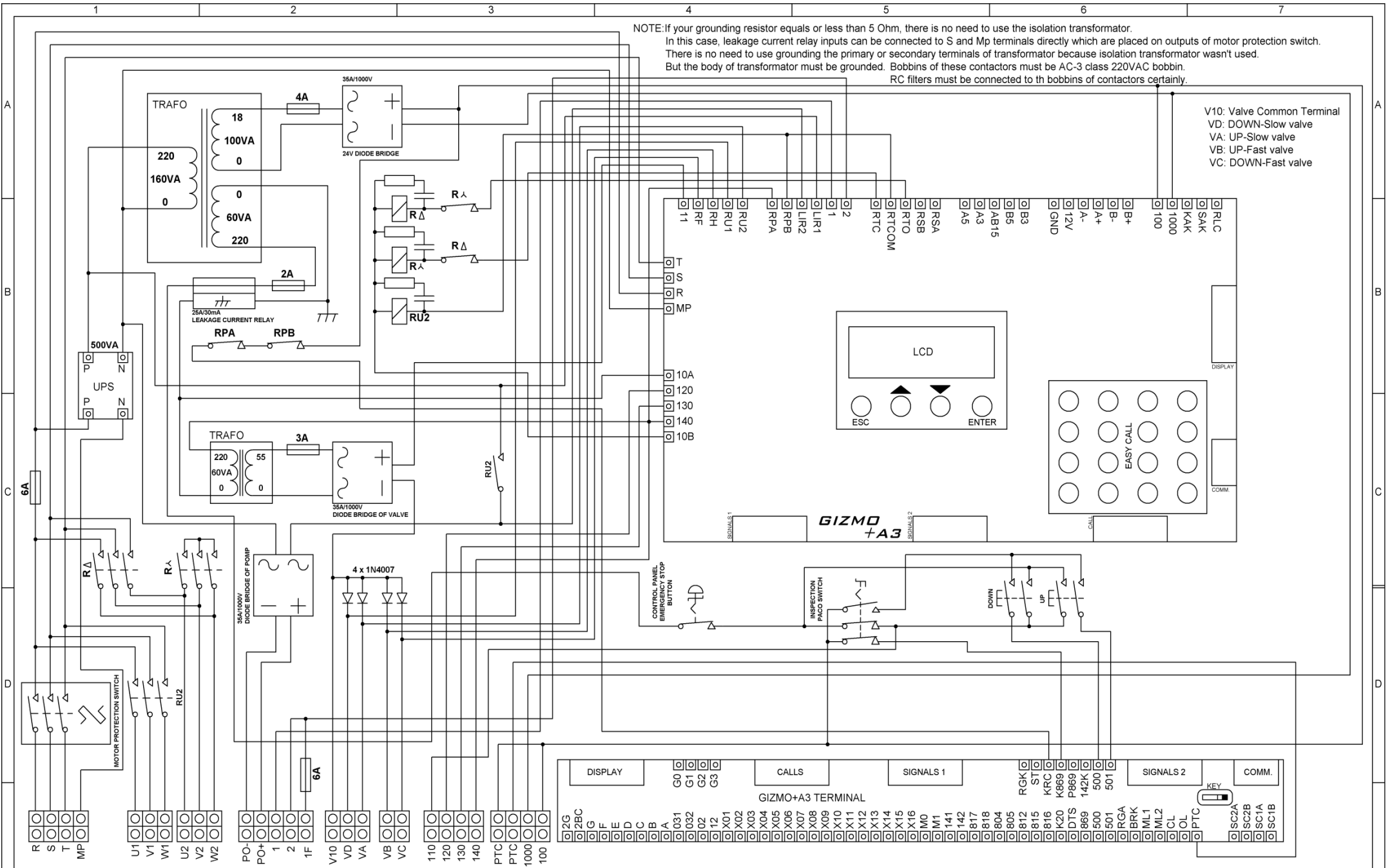

EEM Imp. Exp. Trade Co.  
 Lift Control System

Tel: +90.332 346 46 56 - 66  
 Fax: +90.332 346 46 76

www.eem.com.tr

Project Name Gizmo+A3 Lift Control System

Drawing Name KLEEMANN Hydraulic Control Panel Connection Draw

Description



Drawer HU

Control BA

Version 2.00

Date 05.07.2015

Drawing No 2B

Page 3

NOTE: If your grounding resistor equals or less than 5 Ohm, there is no need to use the isolation transformer.  
 In this case, leakage current relay inputs can be connected to S and Mp terminals directly which are placed on outputs of motor protection switch.  
 There is no need to use grounding the primary or secondary terminals of transformer because isolation transformer wasn't used.  
 But the body of transformer must be grounded. Bobbins of these contactors must be AC-3 class 220VAC bobbin.  
 RC filters must be connected to th bobbins of contactors certainly.

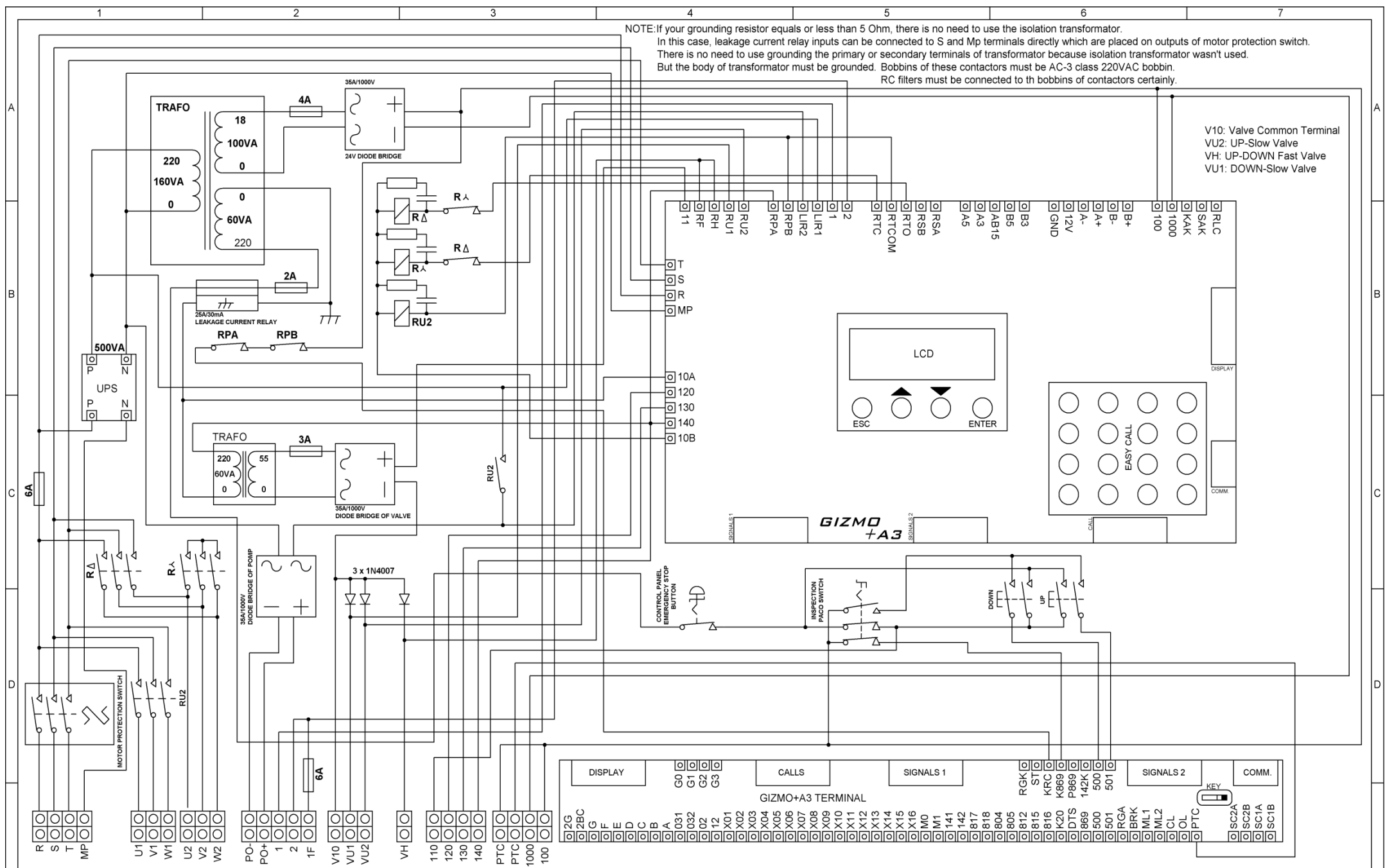

V10: Valve Common Terminal  
 VU2: UP-Slow Valve  
 VH: UP-DOWN Fast Valve  
 VU1: DOWN-Slow Valve

GIZMO+A3 TERMINAL																										
2G	2BC	G	F	E	D	C	B	A	031	G0	G1	G2	G3	CALLS			SIGNALS 1			SIGNALS 2			COMM.			
032	02	12	X01	X02	X03	X04	X05	X06	X07	RGK	ST	KRC	K869	K20	DTS	866	500	501	501	CL	OL	PTC	SC2A	SC2B	SC1A	SC1B
X08	X09	X10	X11	X12	X13	X14	X15	X16	M0	812	815	816	818	804	805	812	815	816	818	BRK	MIL1	MIL2	KEY			
M1	141	142	147	148	149	149	149	149	149	142K	500	501	501	501	501	501	501	501	501	IRGA	IRGA	IRGA				



EEM Imp. Exp. Trade Co.  
 Lift Control System

Project Name Gizmo+A3 Lift Control System

Drawing Name Morris Hydraulic Control Panel Connection Draw

Description



Drawer HU

Control BA

Tel: +90.332 346 46 56 - 66  
 Fax: +90.332 346 46 76

www.eem.com.tr

Version 2.00 Date 05.07.2015 Drawing No 2C Page 4

NOTE: If your grounding resistor equals or less than 5 Ohm, there is no need to use the isolation transformer.  
 In this case, leakage current relay inputs can be connected to S and Mp terminals directly which are placed on outputs of motor protection switch.  
 There is no need to use grounding the primary or secondary terminals of transformer because isolation transformer wasn't used.  
 But the body of transformer must be grounded. Bobbins of these contactors must be AC-3 class 220VAC bobbin.  
 RC filters must be connected to the bobbins of contactors certainly.

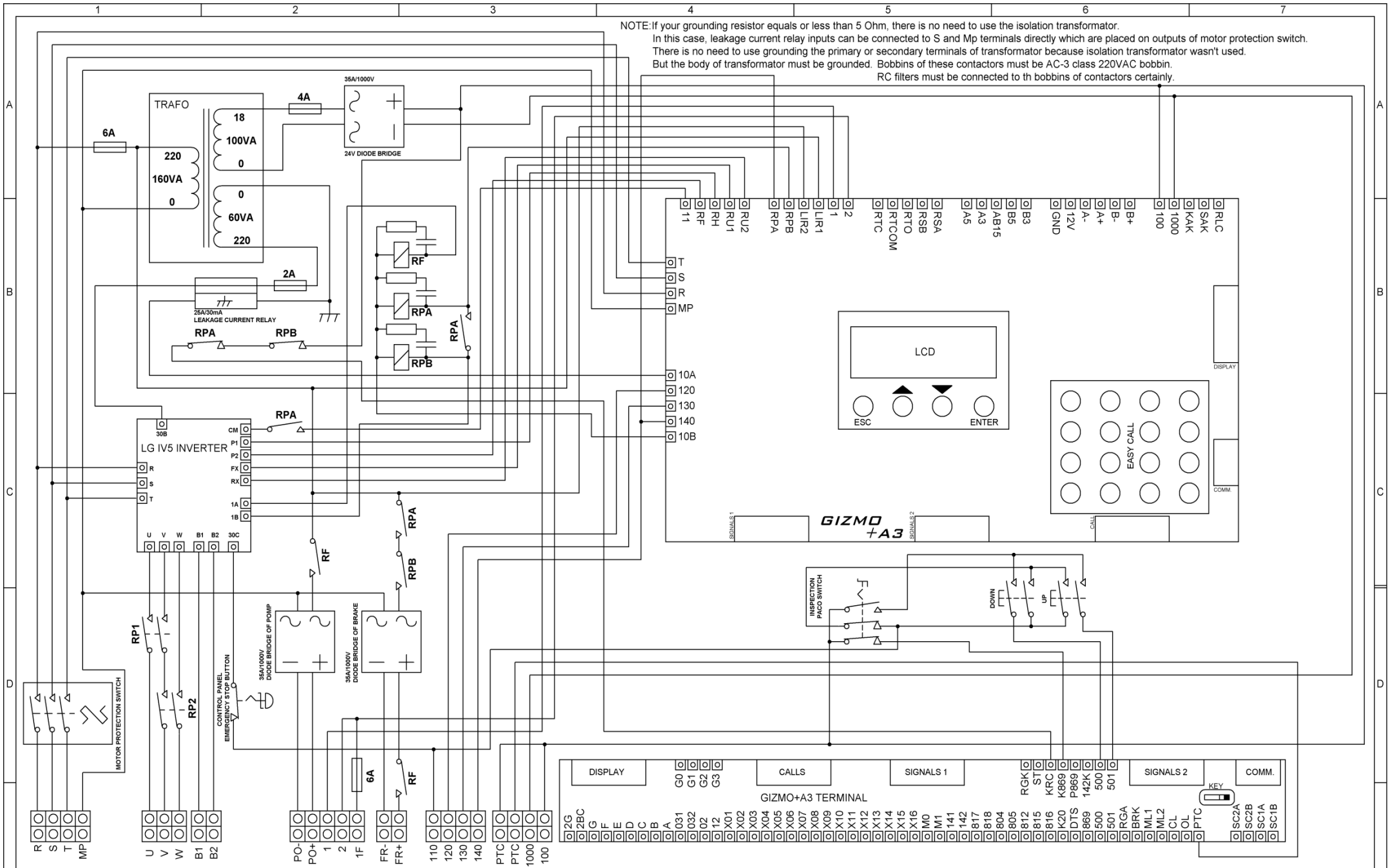

EEM Imp. Exp. Trade Co.  
 Lift Control System

Tel: +90.332 346 46 56 - 66  
 Fax: +90.332 346 46 76

www.eem.com.tr

Project Name Gizmo+A3 Lift Control System

Drawing Name LG IV5 Speed Controlled Control Panel Connection Draw

Description

Version 2.00

Date 05.07.2015

Drawing No 3A

Page 5



Drawer HU

Control BA

NOTE: If your grounding resistor equals or less than 5 Ohm, there is no need to use the isolation transformer.  
 In this case, leakage current relay inputs can be connected to S and Mp terminals directly which are placed on outputs of motor protection switch.  
 There is no need to use grounding the primary or secondary terminals of transformer because isolation transformer wasn't used.  
 But the body of transformer must be grounded. Bobbins of these contactors must be AC-3 class 220VAC bobbin.  
 RC filters must be connected to the bobbins of contactors certainly.

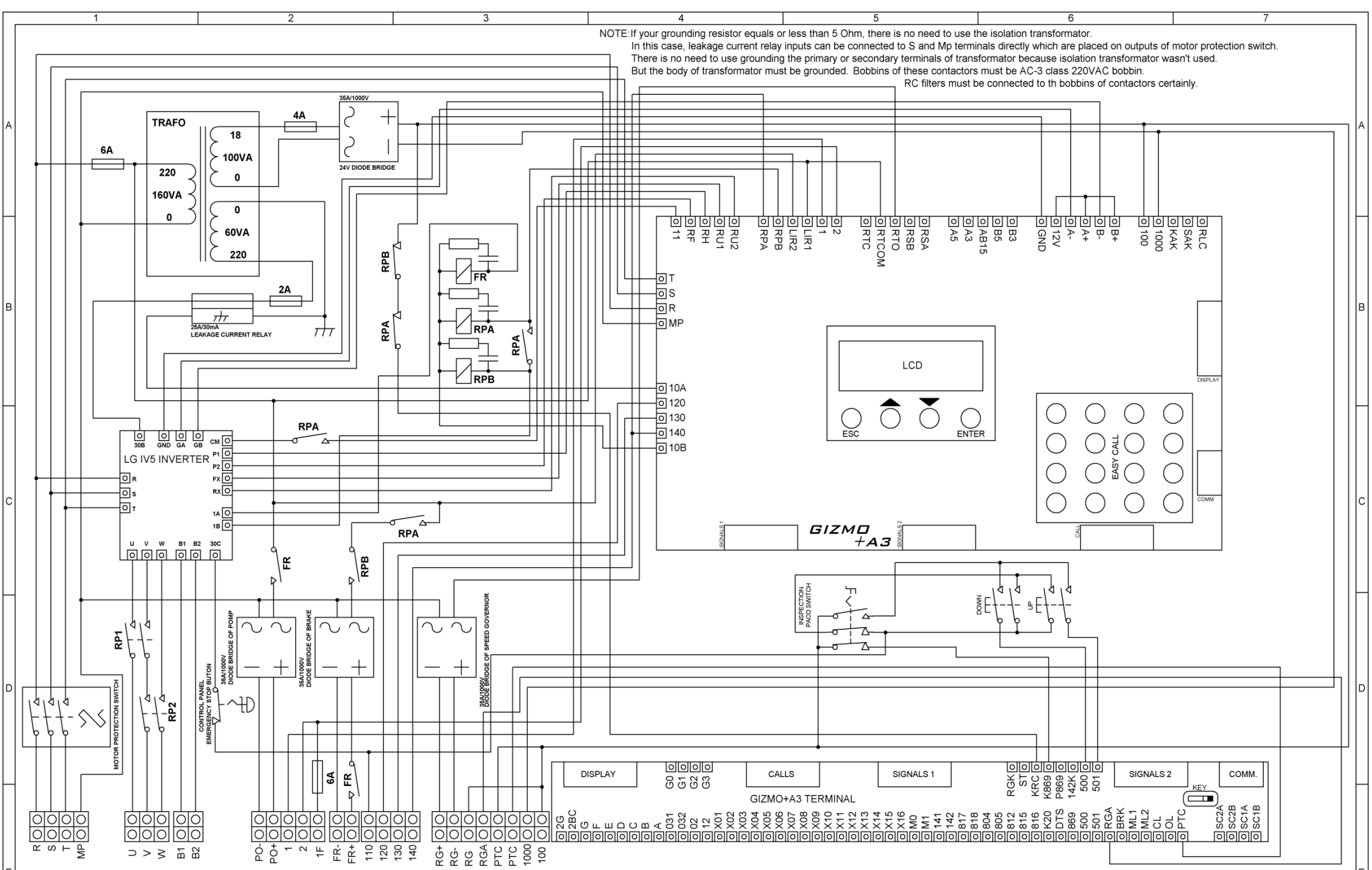

EEM Imp. Exp. Trade Co.  
Lift Control System

Tel: +90.332 346 46 56 - 66  
Fax: +90.332 346 46 76

www.eem.com.tr

Project Name Gizmo+A3 Lift Control System  
Drawing Name LG IV5 Speed Controlled A3 Control Panel Connection Draw

Description



Drawer HU

Control BA

Version 2.00

Date 04.02.2015

Drawing No 3B

Page 6

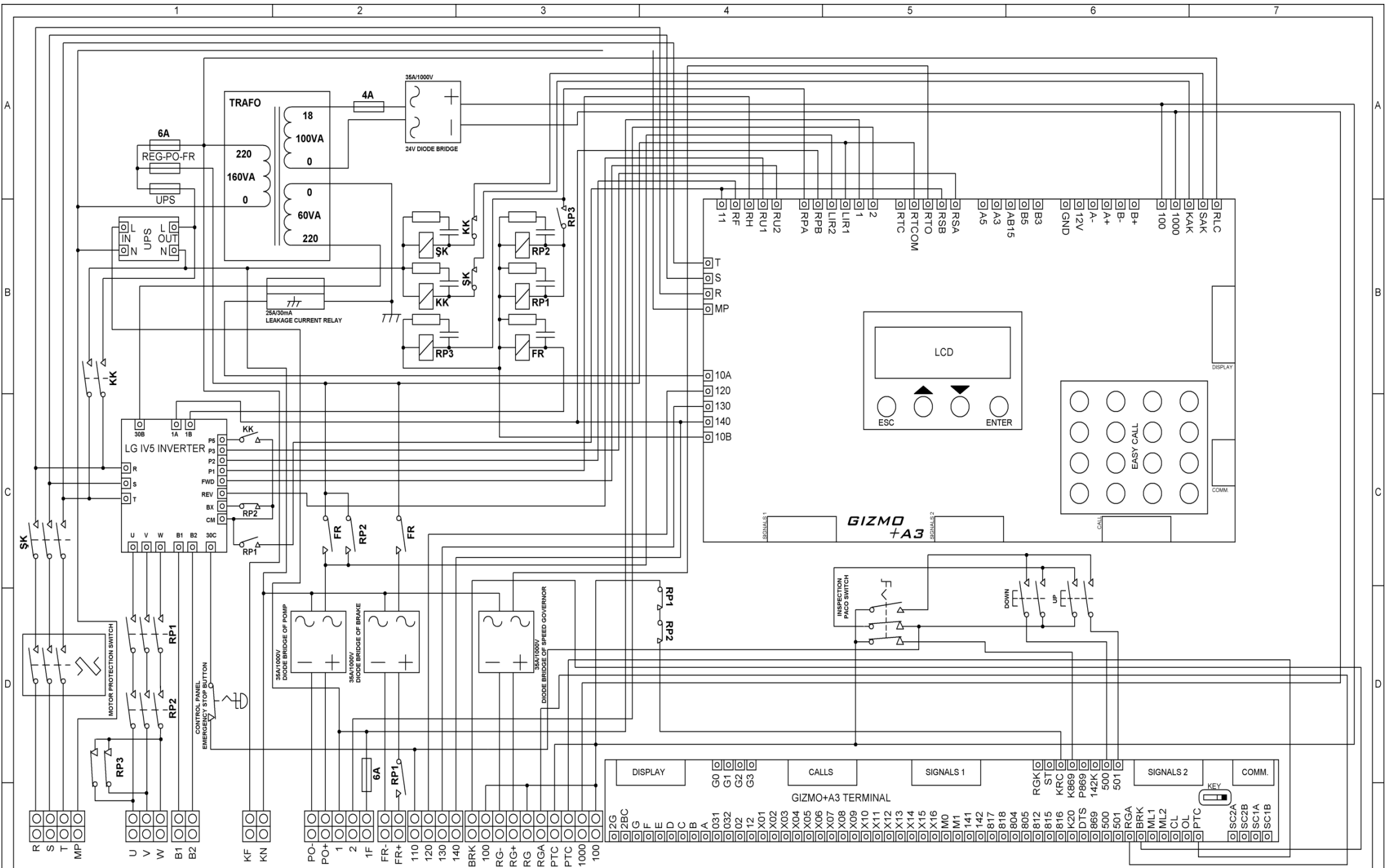

EEM Imp. Exp. Trade Co.  
Lift Control System

Project Name Gizmo+A3 Lift Control System

Drawing Name LG IV5 Speed Controlled Gearless A3 Control Panel with UPS Rescuer Connection Draw



Drawer HU

Control BA

Tel: +90.332 346 46 56 - 66  
Fax: +90.332 346 46 76

www.eem.com.tr

Description

Version 2.00

Date 05.07.2015

Drawing No 3C

Page 7

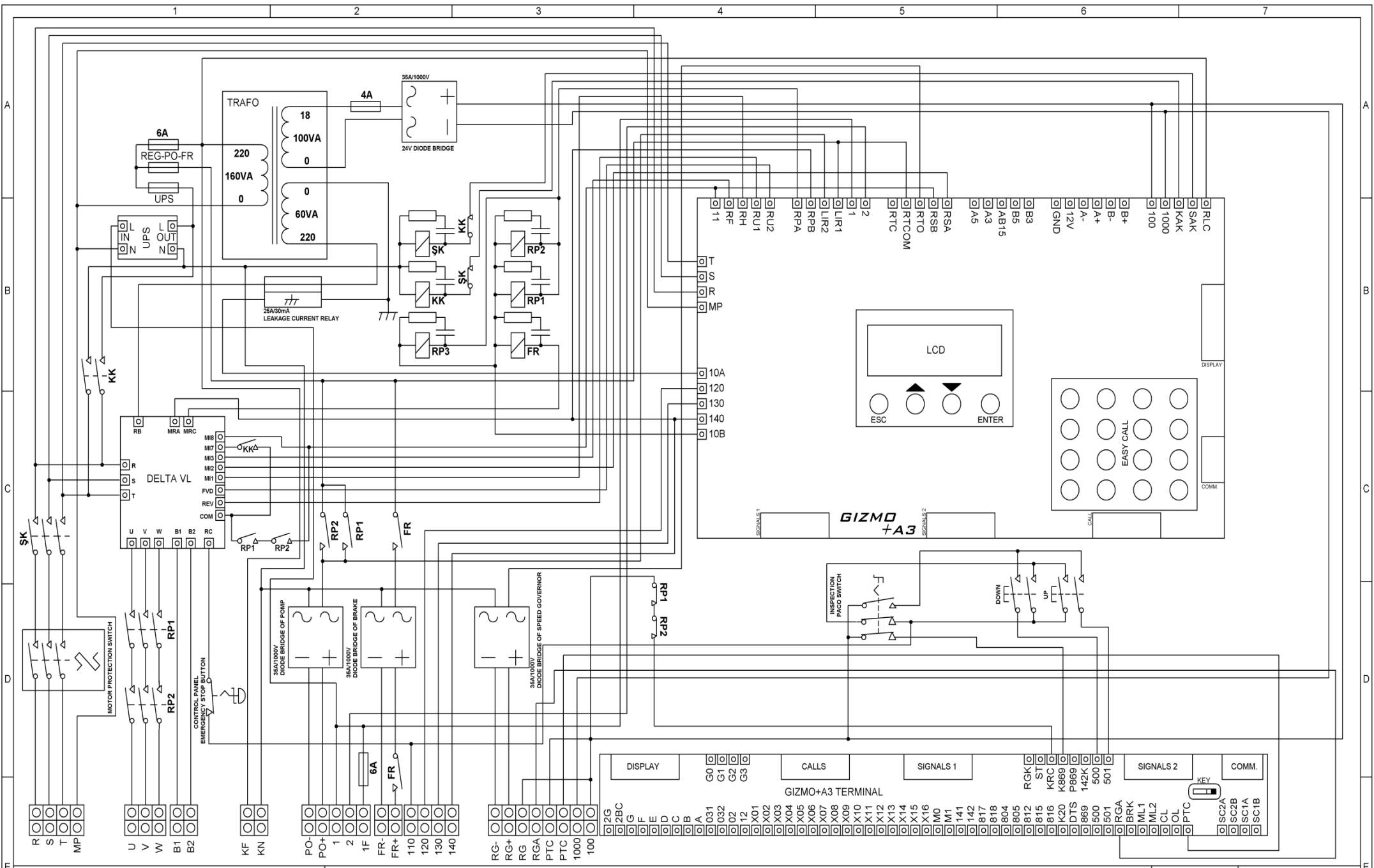

EEM Imp. Exp. Trade Co.  
Lift Control System

Project Name Gizmo+A3 Lift Control System		Drawer HU	
Drawing Name DELTA VL Speed Controlled A3 Control Panel Connection Draw with UPS Rescuer		Control BA	
Description		Version 2.00	Date 05.07.2015
		Drawing No 4	Page 8

Tel: +90.332 346 46 56 - 66  
Fax: +90.332 346 46 76

www.eem.com.tr



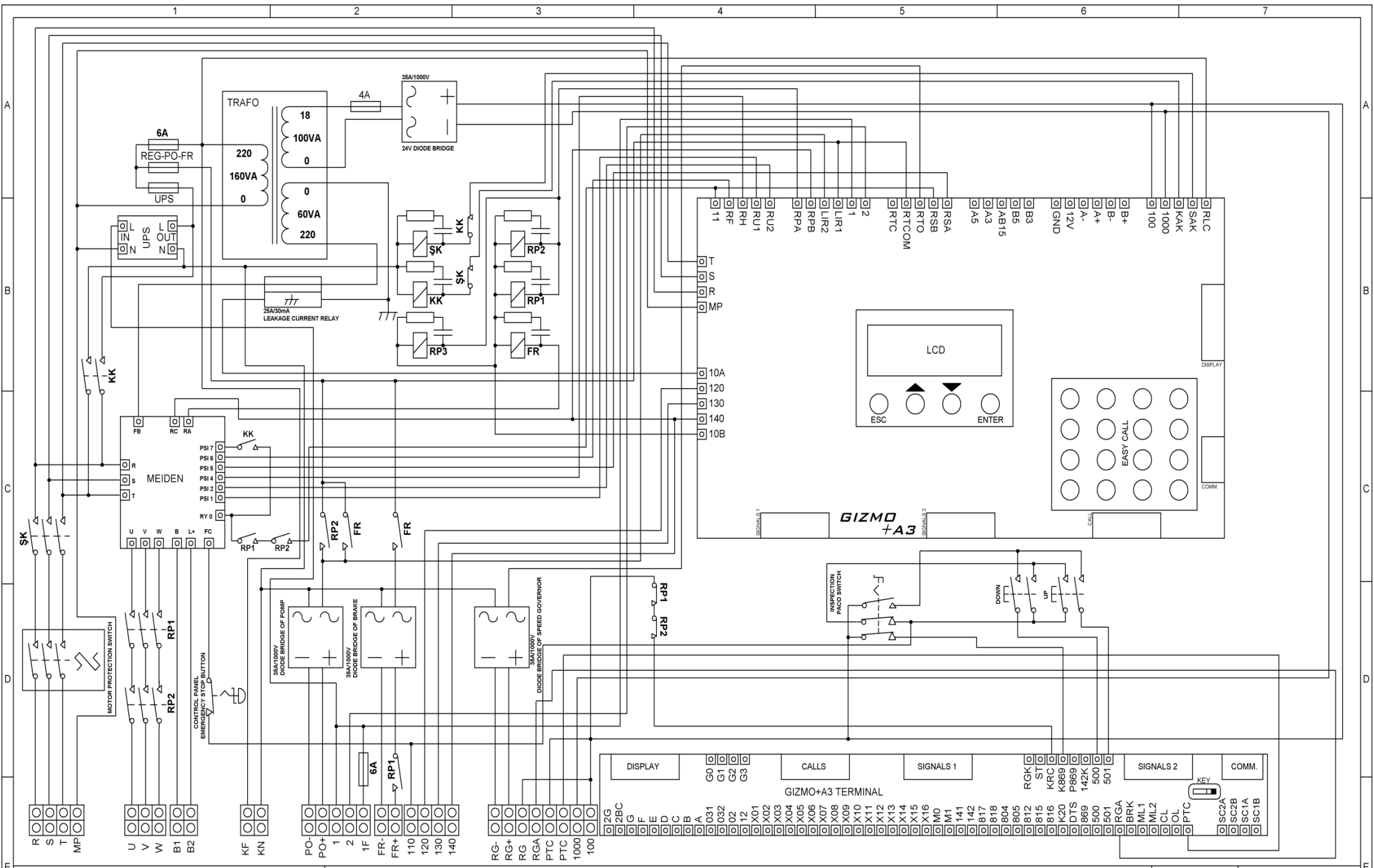

EEM Imp. Exp. Trade Co.  
Lift Control System

Tel: +90.332 346 46 56 - 66  
Fax: +90.332 346 46 76

www.eem.com.tr

Project Name Gizmo+A3 Lift Control System

Drawing Name MEIDEN Speed Controlled A3 Control Panel Connection Draw with UPS Rescuer

Description

Version 2.00

Date 05.07.2015

Drawing No 5

Page 9



Drawer HU

Control BA

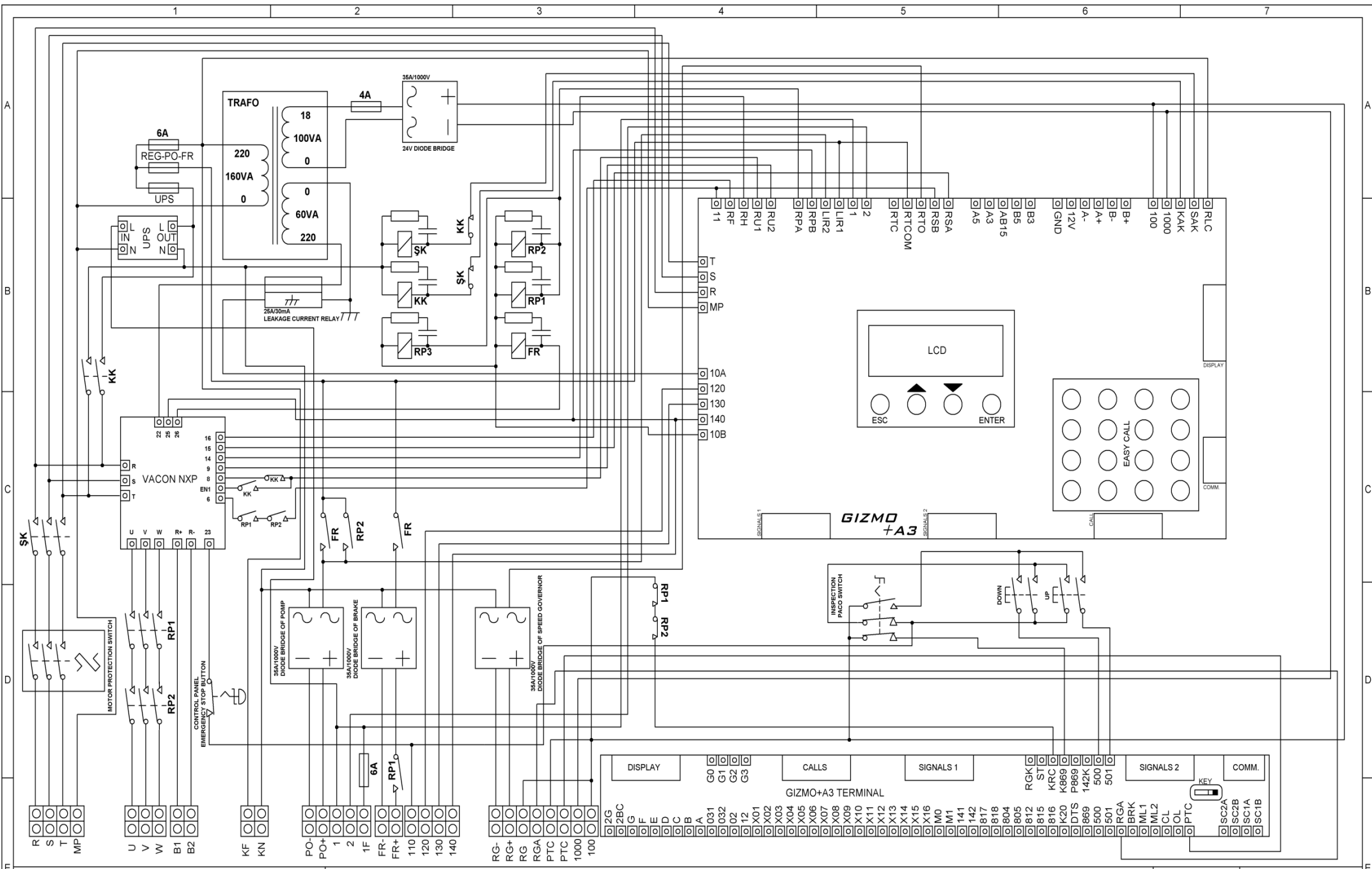

EEM Imp. Exp. Trade Co.  
Lift Control System

Tel: +90.332 346 46 56 - 66  
Fax: +90.332 346 46 76

www.eem.com.tr

Project Name Gizmo+A3 Lift Control System  
Drawing Name VACON NXP Speed Controlled A3 Control Panel Connection Draw with UPS Rescuer

Description

Version 2.00

Date 05.07.2015

Drawing No 6

Page 10



Drawer HU  
Control BA

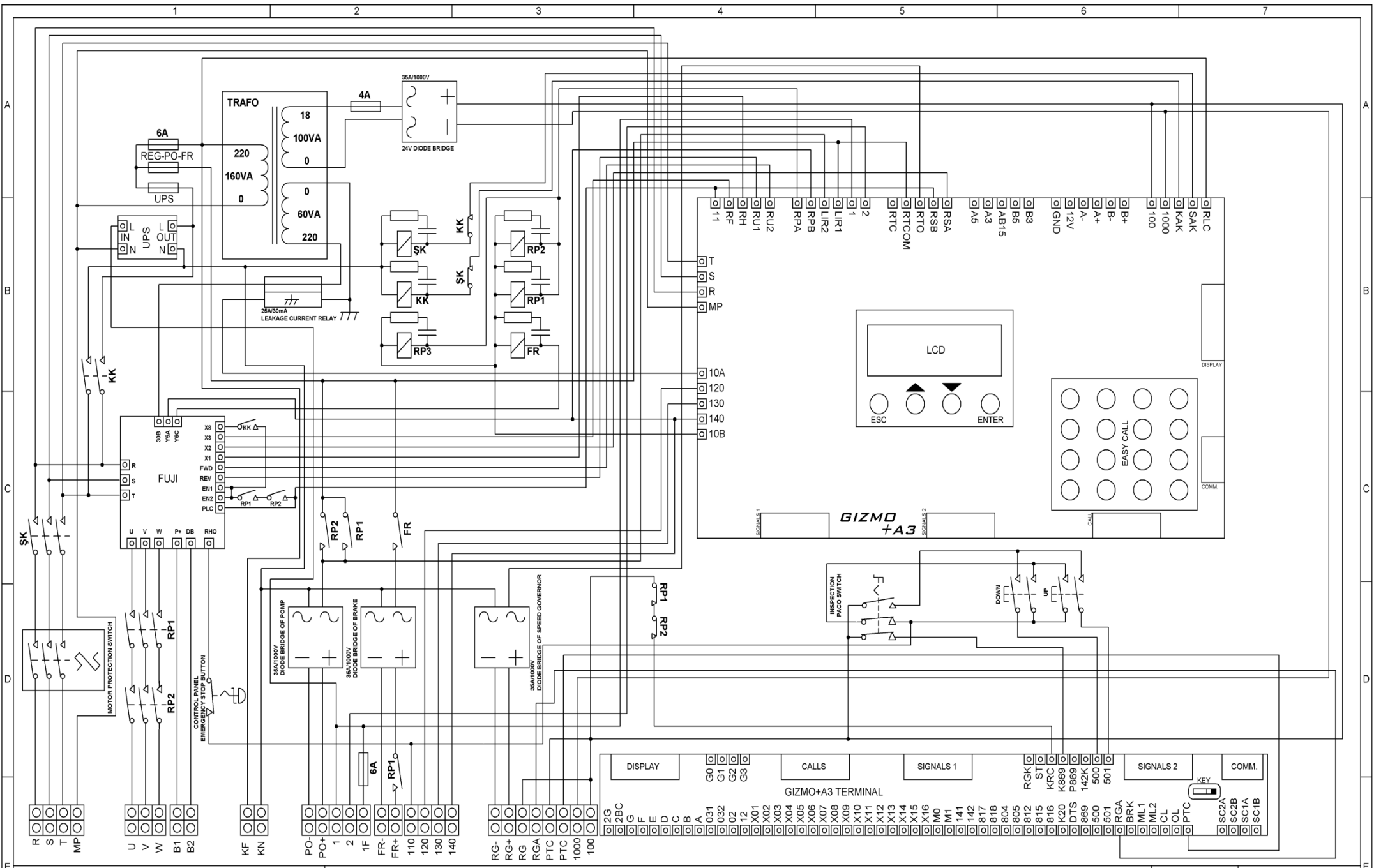

EEM Imp. Exp. Trade Co.  
Lift Control System

Project Name Gizmo+A3 Lift Control System  
 Drawing Name FUJI Speed Controlled A3 Control Panel Connection Draw with UPS Rescuer  
 Description

CE  
 Drawer HU  
 Control BA

Tel: +90.332 346 46 56 - 66  
 Fax: +90.332 346 46 76

www.eem.com.tr

Version 2.00 Date 05.07.2015 Drawing No 7 Page 11

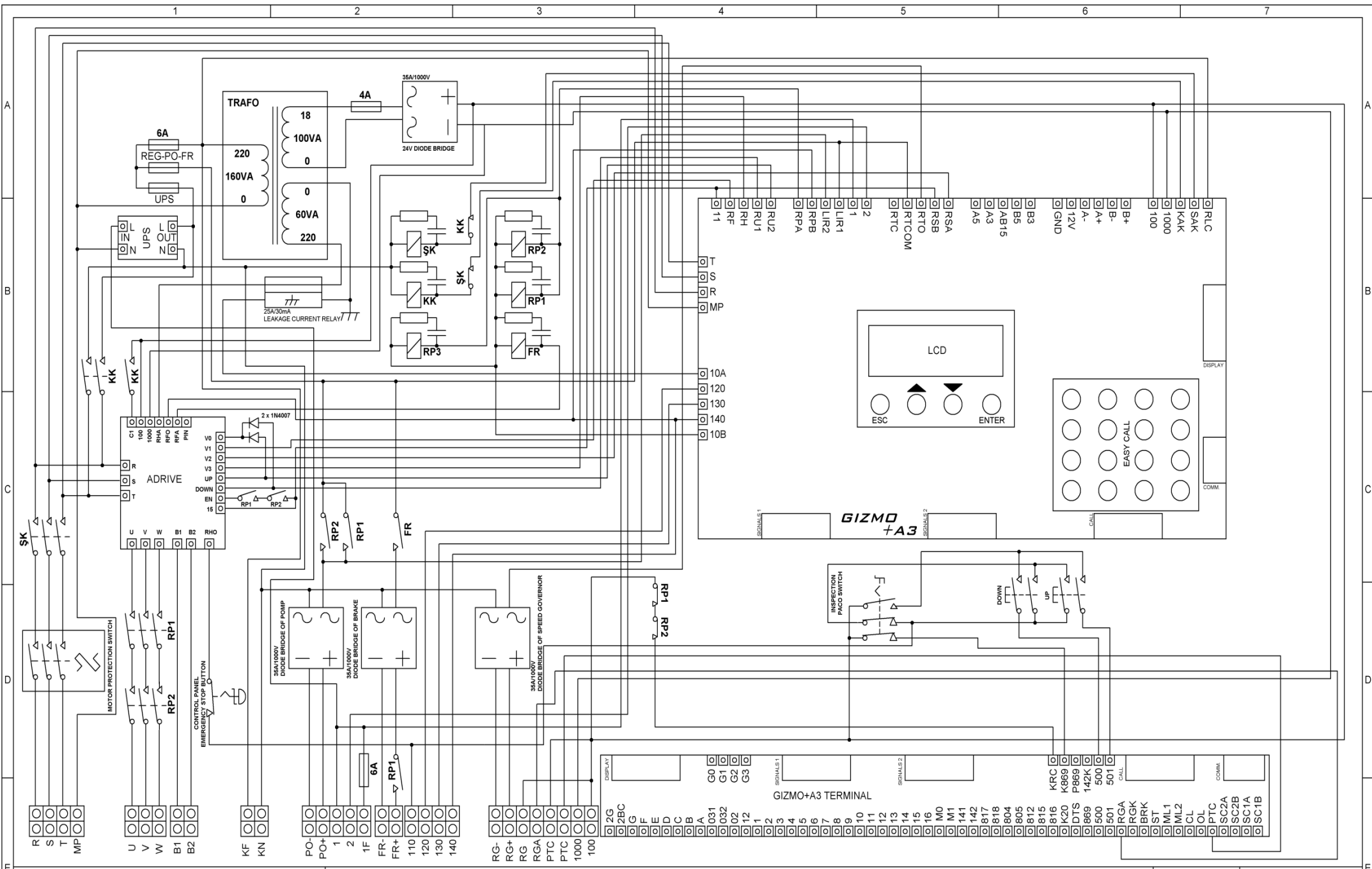

**eem** EEM Imp. Exp. Trade Co.  
 Lift Control System  
 Tel: +90.332 346 46 56 - 66  
 Fax: +90.332 346 46 76  
 www.eem.com.tr

Project Name **Gizmo+A3 Lift Control System**  
 Drawing Name **ADRIVE Speed Controlled A3 Control Panel Connection Draw with UPS Rescuer**  
 Description

**CE** Drawer HU  
 Control BA  
 Version 2.00 Date 05.07.2015 Drawing No 8 Page 12

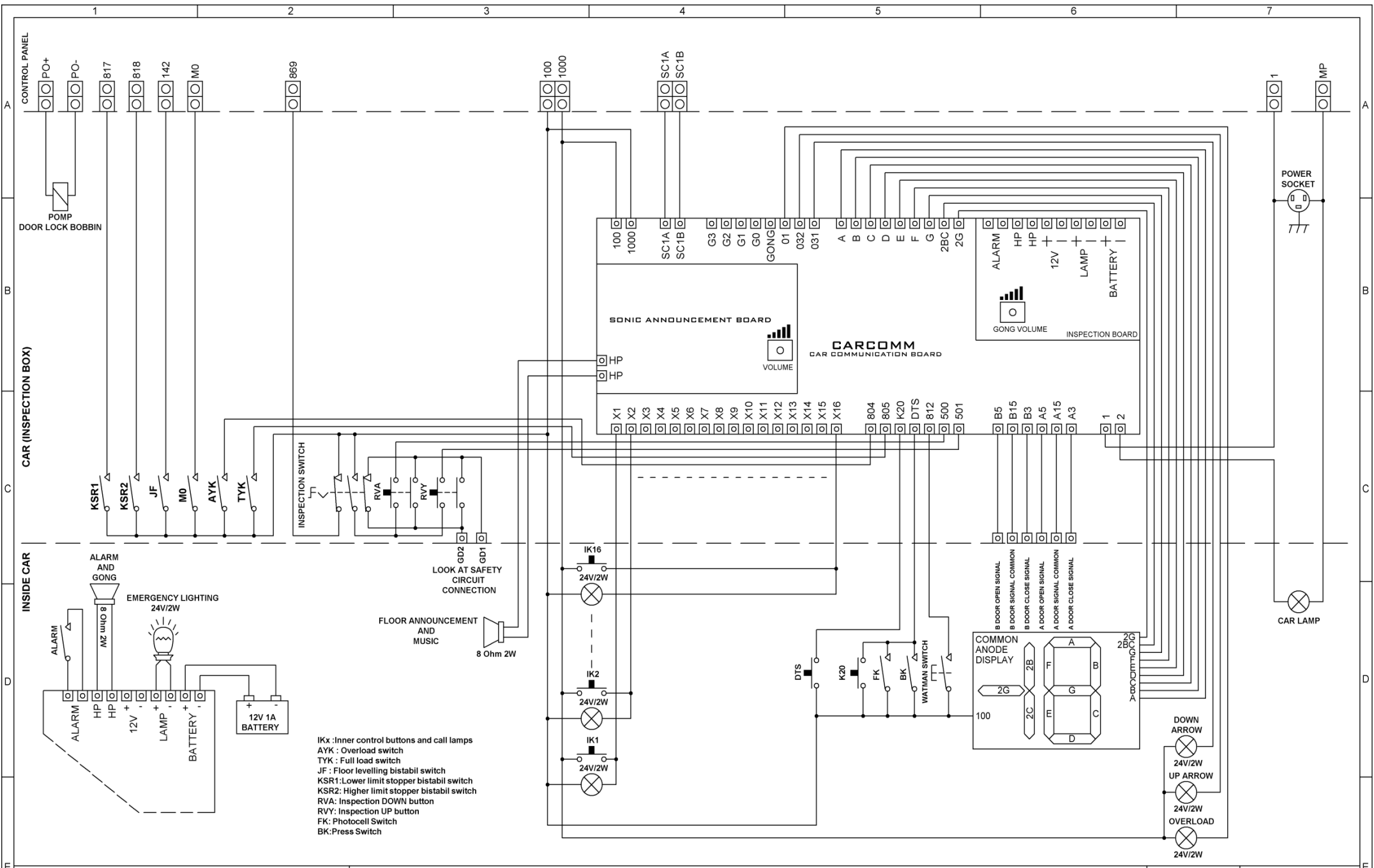

EEM Imp. Exp. Trade Co.  
Lift Control System

Project Name Gizmo+A3 Lift Control System

Drawing Name CARCOMM Car Communication Board and Inspection Board Connection Draw

Description

Version 2.00

Date 05.07.2015

Drawing No 9

Page 13



Drawer HU

Control BA

Tel: +90.332 346 46 56 - 66

Fax: +90.332 346 46 76

www.eem.com.tr

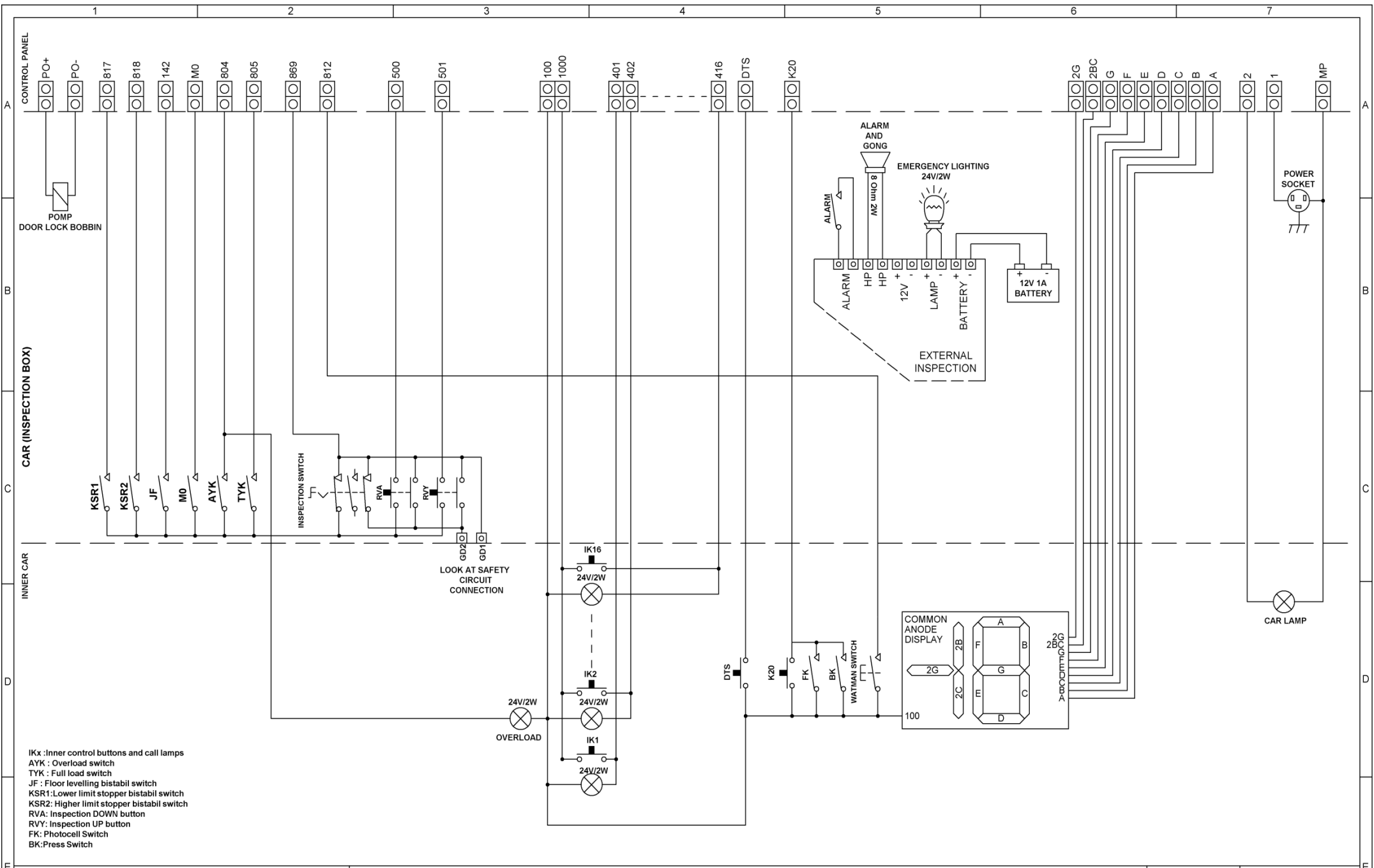

EEM Imp. Exp. Trade Co.  
Lift Control System

Project Name Gizmo+A3 Lift Control System

Drawing Name Parallel Car Connection

Description

Version 2.00

Date 05.07.2015

Drawing No 10

Drawer HU

Control BA

Page 14



Tel: +90.332 346 46 56 - 66

Fax: +90.332 346 46 76

www.eem.com.tr

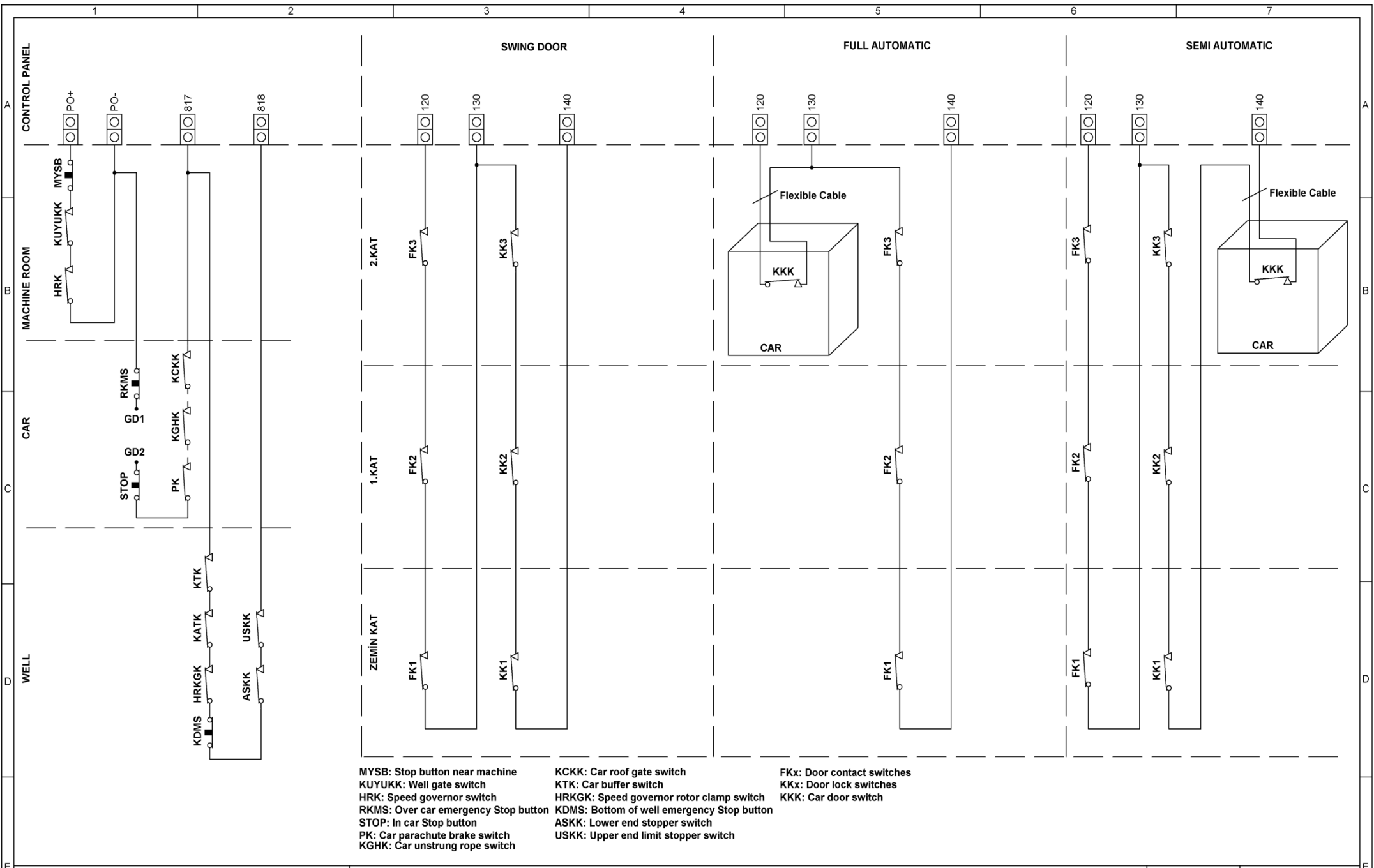

MYSB: Stop button near machine  
 KUYUUKK: Well gate switch  
 HRK: Speed governor switch  
 RKMS: Over car emergency Stop button  
 STOP: In car Stop button  
 PK: Car parachute brake switch  
 KGHK: Car unstrung rope switch  
 KCKK: Car roof gate switch  
 KTK: Car buffer switch  
 HRKGK: Speed governor rotor clamp switch  
 KDMS: Bottom of well emergency Stop button  
 ASKK: Lower end stopper switch  
 USKK: Upper end limit stopper switch  
 FKx: Door contact switches  
 KKx: Door lock switches  
 KKK: Car door switch



EEM Imp. Exp. Trade Co.  
Lift Control System

Tel: +90.332 346 46 56 - 66  
Fax: +90.332 346 46 76

www.eem.com.tr

Project Name Gizmo+A3 Lift Control System

Drawing Name Safety Circuit Connection

Description

Version 2.00

Date 05.07.2015

Drawing No 11

Drawer HU

Control BA

Page 15



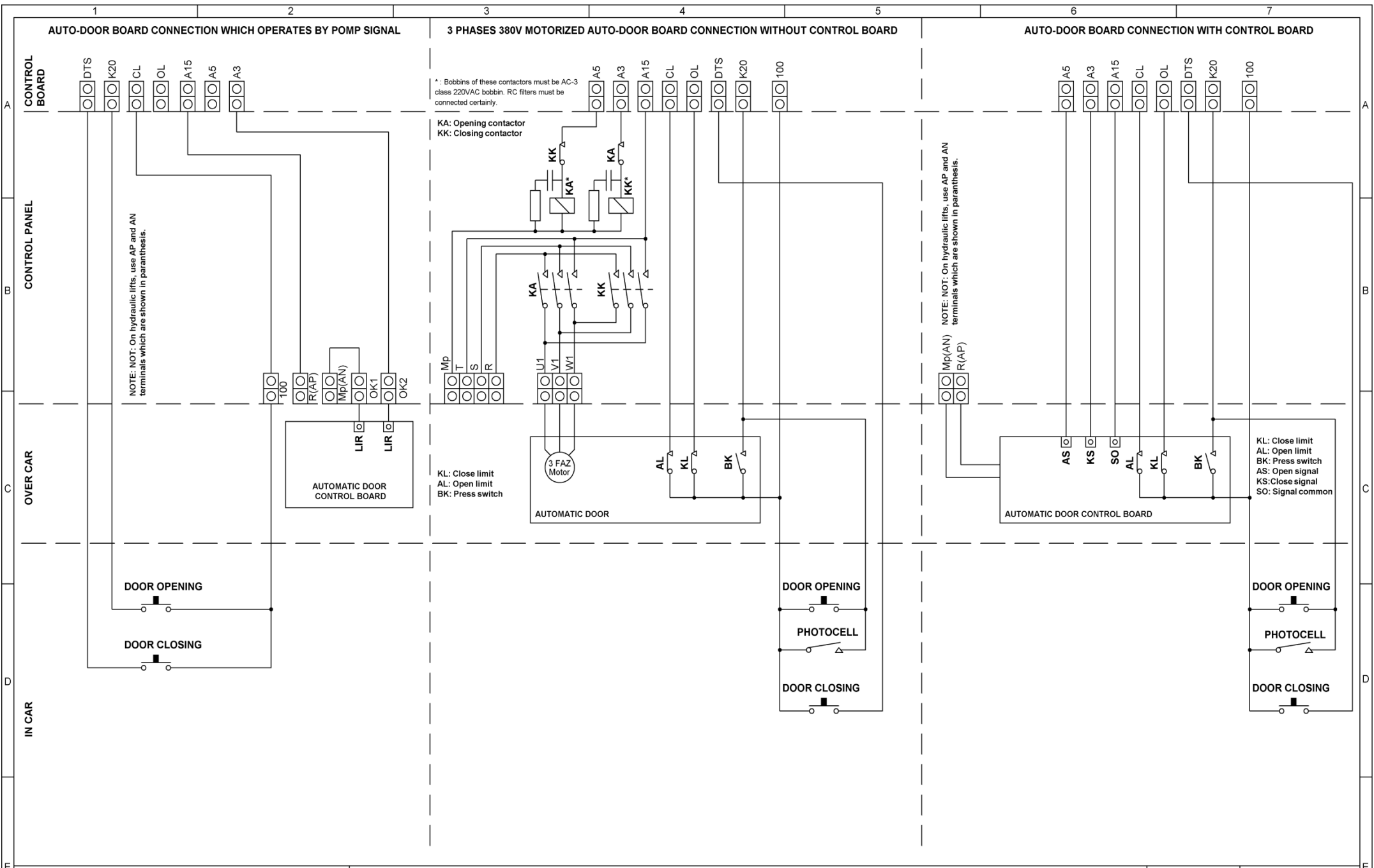

EEM Imp. Exp. Trade Co.  
Lift Control System

Tel: +90.332 346 46 56 - 66  
Fax: +90.332 346 46 76

www.eem.com.tr

Project Name	Gizmo+A3 Lift Control System		
Drawing Name	Door Control Board Connection Draw		
Description			



Drawer	HU
Control	BA
Version	2.00
Date	05.07.2015
Drawing No	12
Page	16

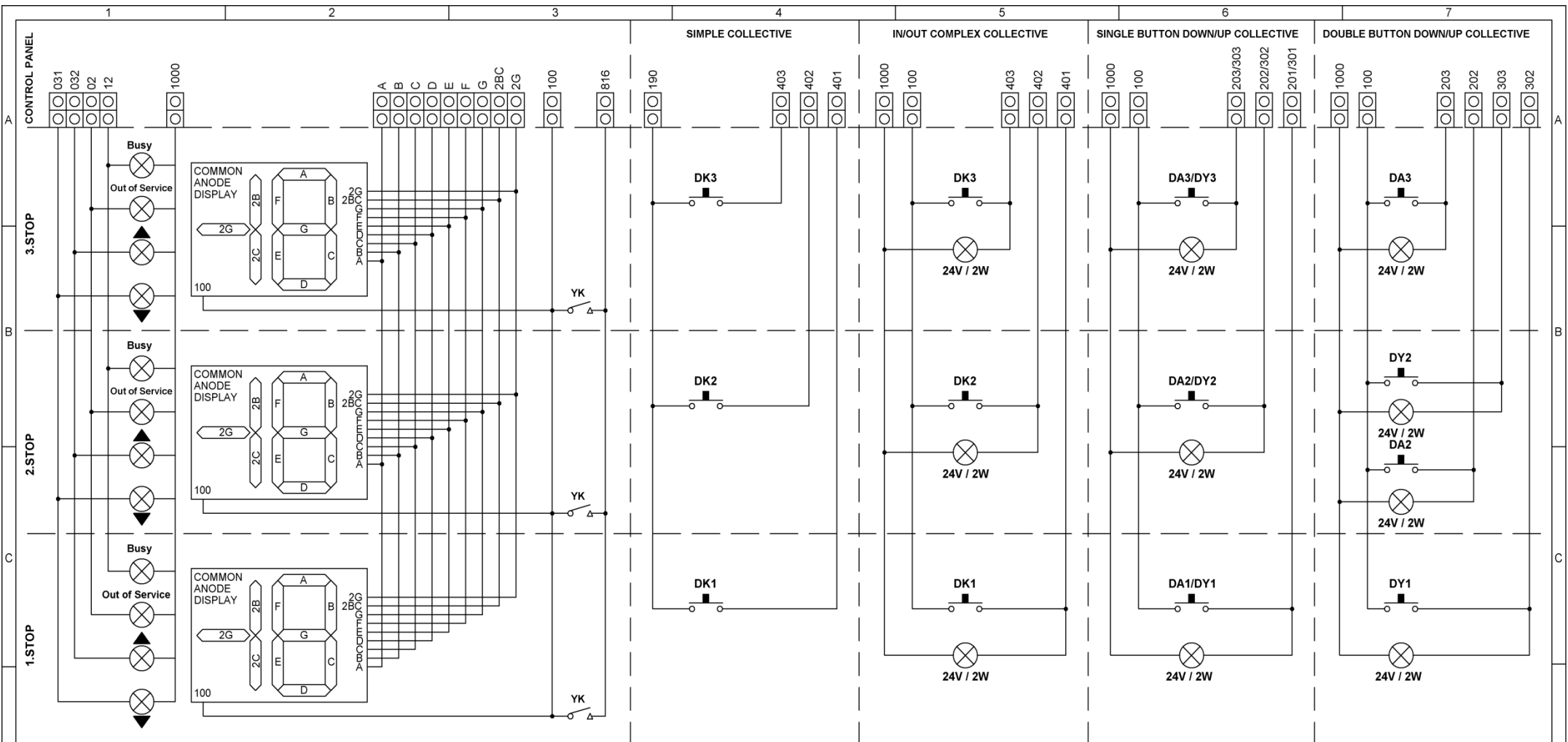

DKx: Call buttons and lamps  
 DAx: DOWN call buttons and lamps  
 DYx: UP call buttons and lamps  
 YK: Fire switch

NOTE: Common of Down arrow, Up arrow, out of service and busy signals set 100 as a default settings.  
 If you want you can change with jumper on Gizmo+A3 control board as 1000.

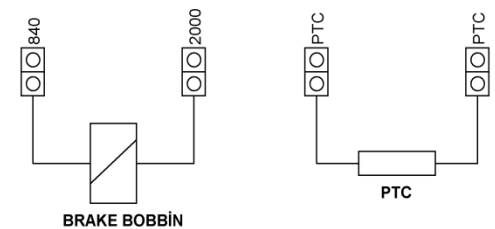

**MACHINE ROOM**



EEM Imp. Exp. Trade Co.  
 Lift Control System

Project Name Gizmo+A3 Lift Control System  
 Drawing Name Floor installation, Brake and Motor thermistor connection



Drawer HU  
 Control BA

Tel: +90.332 346 46 56 - 66  
 Fax: +90.332 346 46 76

www.eem.com.tr

Description

Version 2.00

Date 05.07.2015

Drawing No 13

Page 17

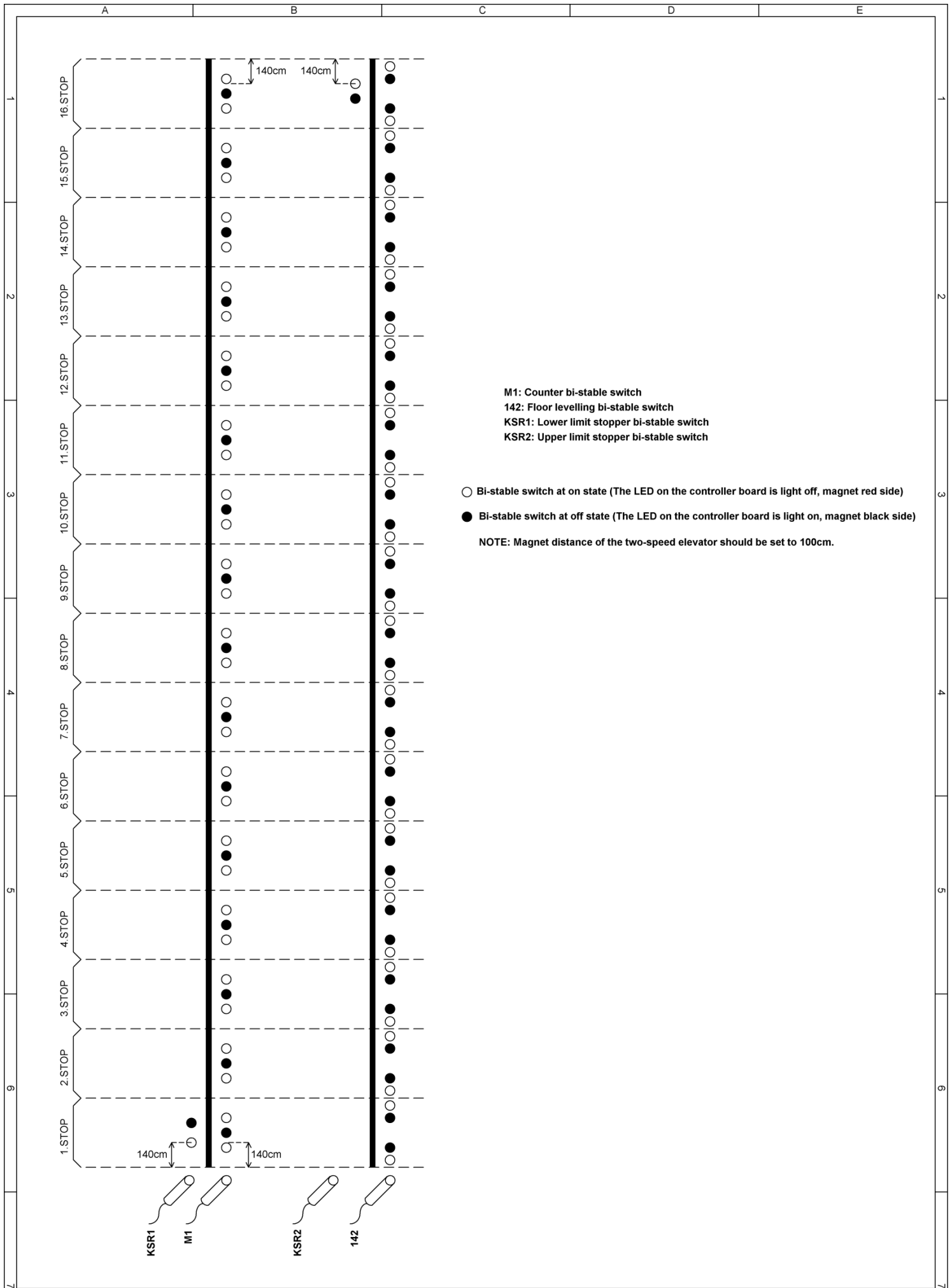

M1: Counter bi-stable switch  
 142: Floor levelling bi-stable switch  
 KSR1: Lower limit stopper bi-stable switch  
 KSR2: Upper limit stopper bi-stable switch

- Bi-stable switch at on state (The LED on the controller board is light off, magnet red side)
- Bi-stable switch at off state (The LED on the controller board is light on, magnet black side)

NOTE: Magnet distance of the two-speed elevator should be set to 100cm.



EEM Imp. Exp. Trade Co.  
 Lift Control System

Tel: +90.332 346 46 56 - 66

Fax: +90.332 346 46 76

www.eem.com.tr

Project Name Gizmo+A3 Lift Control System

Drawing Name M1 counter magnet order for double speed and VVVF speed controlled roped lift

Description

Version 2.00

Date 05.07.2015



Drawer HU

Control BA

Drawing No 14

Page 18

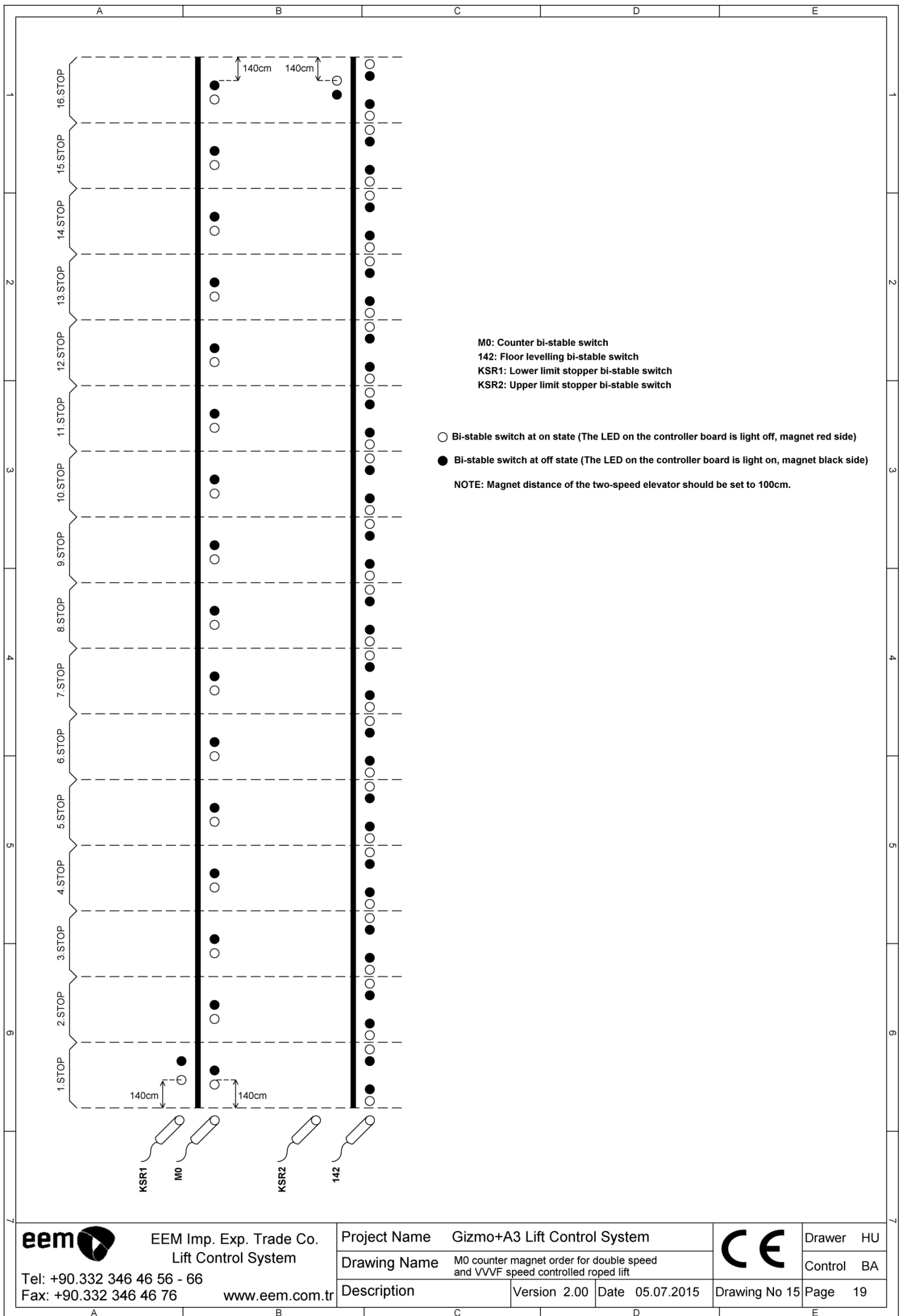

EEM Imp. Exp. Trade Co.  
Lift Control System

Tel: +90.332 346 46 56 - 66  
Fax: +90.332 346 46 76

www.eem.com.tr

Project Name	Gizmo+A3 Lift Control System		
Drawing Name	M0 counter magnet order for double speed and VVVF speed controlled roped lift		
Description	Version 2.00	Date 05.07.2015	Drawing No 15



Drawer	HU
Control	BA
Page	19

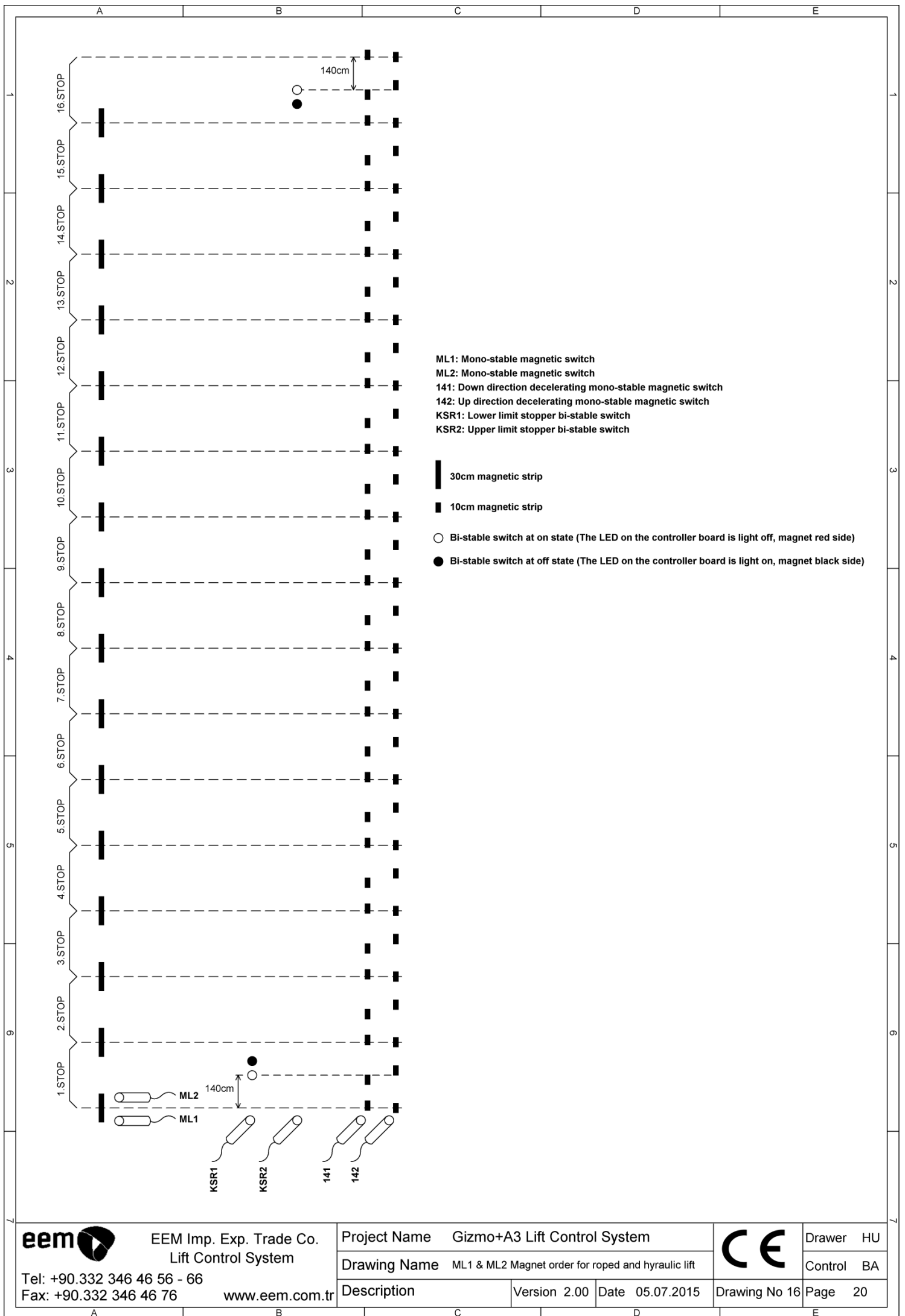

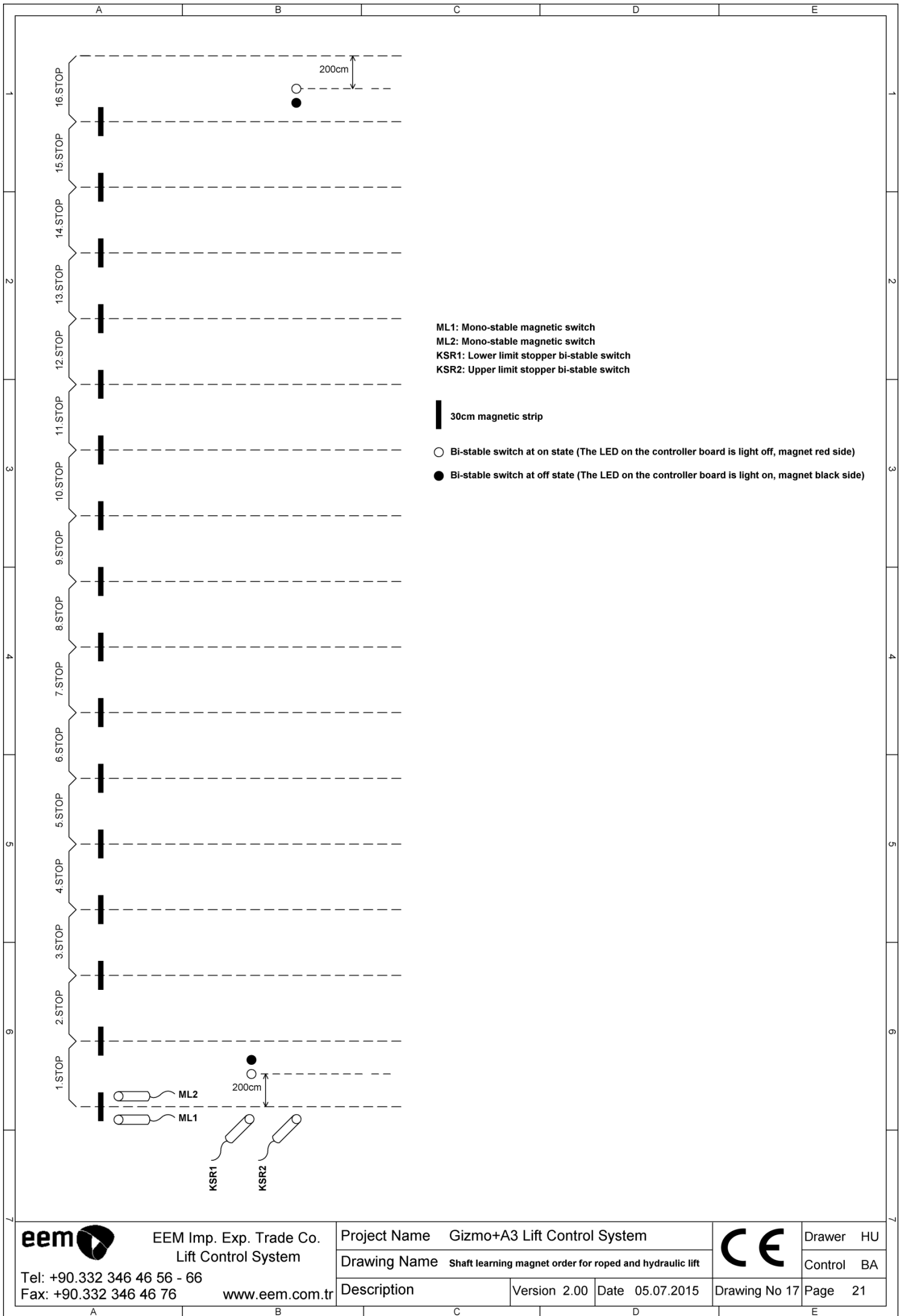

ML1: Mono-stable magnetic switch  
 ML2: Mono-stable magnetic switch  
 KSR1: Lower limit stopper bi-stable switch  
 KSR2: Upper limit stopper bi-stable switch

30cm magnetic strip

○ Bi-stable switch at on state (The LED on the controller board is light off, magnet red side)  
 ● Bi-stable switch at off state (The LED on the controller board is light on, magnet black side)



EEM Imp. Exp. Trade Co.  
 Lift Control System

Tel: +90.332 346 46 56 - 66  
 Fax: +90.332 346 46 76

www.eem.com.tr

Project Name	Gizmo+A3 Lift Control System		
Drawing Name	Shaft learning magnet order for roped and hydraulic lift		
Description	Version 2.00	Date 05.07.2015	Drawing No 17



Drawer	HU
Control	BA
Page	21

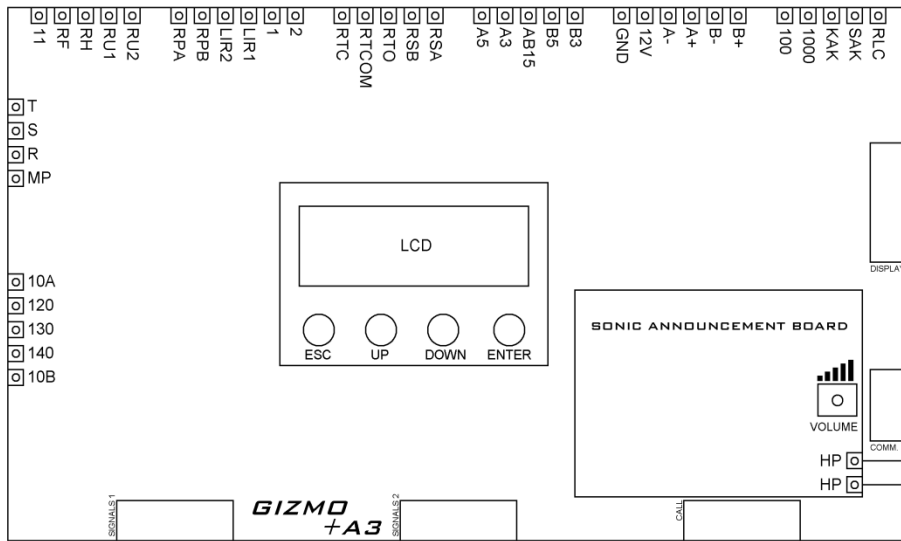

**Note:** SONIC board provides, floor announcement, out of service, over-load, rescue and photocell warning announcements. Besides it can play music during the travel. (The playlist in the memory card is played randomly).  
 When SONIC Announcement board is used with GIZMO+A3, it is plugged into control board and without needing any cable connection, all signals are received from the control board. Only a loudspeaker connection is sufficient. Playing music, language and the starting floor can be adjusted by DIPSWITCH placed on the SONIC board.

8 Ohm 2W Speaker

How to make the setting of SONIC announcement board described in Page 23 / Drawing 21

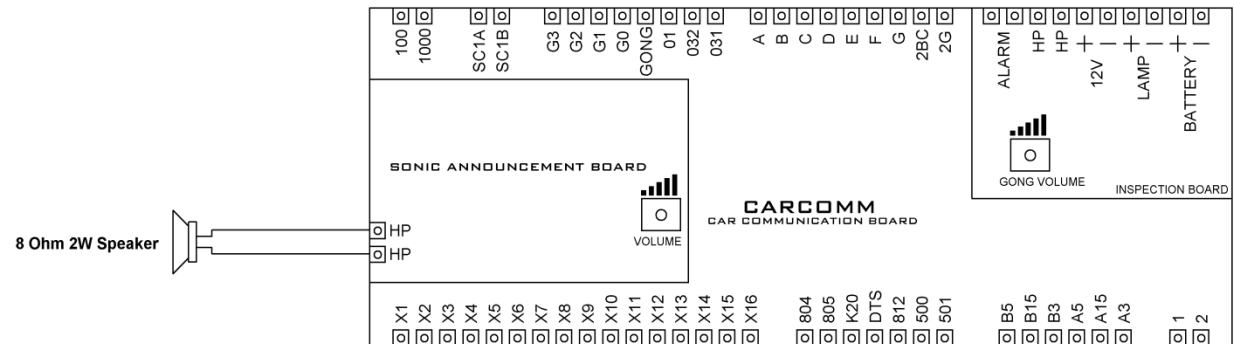

8 Ohm 2W Speaker



EEM Imp. Exp. Trade Co.  
Lift Control System

Tel: +90.332 346 46 56 - 66  
Fax: +90.332 346 46 76

www.eem.com.tr

Project Name Gizmo+A3 Lift Control System

Drawing Name SONIC Announcement Board connection draw with GIZMO+A3 and CARCOMM

Description

Version 2.00

Date 05.07.2015

Drawing No 18

Drawer HU  
Control BA



Page 22

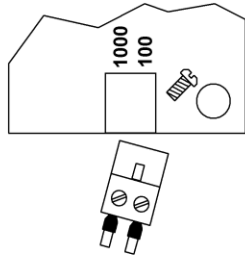

**1. STEP:**

Remove 100-1000 terminal of CARCOMM or GIZMO+A3 to power off that connect SONIC announcement board.

**2. STEP:**

Remove memory card from the microSD card connector.

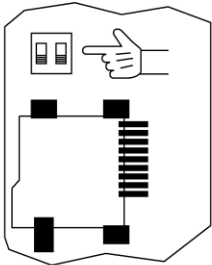
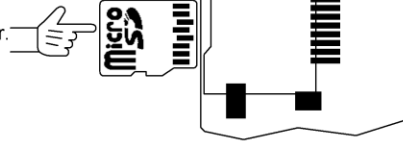

**3. STEP:**

Select the setting you want to change using with DIPSWITCH. Connect 100-1000 terminal to SONIC sound announcement board.

**4. STEP:**

Remove 804 (Overloaded signal) signal from 804 terminal and connect 100 signal to 804 terminal.

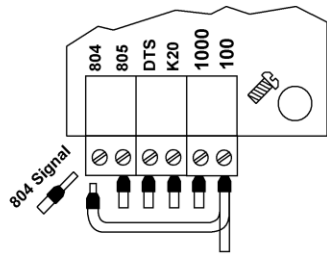
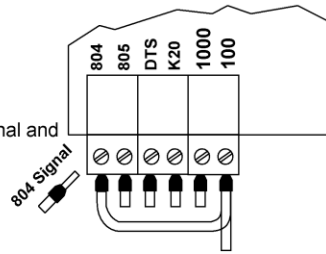

**5. STEP:**

Select the parameter you want to change using with DIPSWITCH after hear warning sound. When you hear warning sound second time, save parameter that you change. If you want to change other parameter, remove 100 signal from 804 terminal and repeat the process from 3. STEP.

**6. STEP:**

After complete the parameter settings, remove 100-1000 terminal to power off. Carefully insert the Micro SD memory card slot. Connect 804 signal to 804 terminal. Connect 100-1000 terminal to CARCOMM or GIZMO+A3 board to power on. Test your board to sure saved parameter.

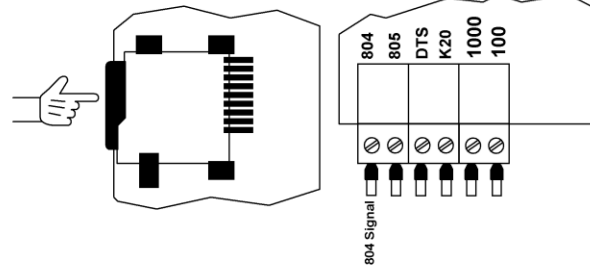

<p><b>LANGUAGE SETTING</b></p>		<p><b>1 2</b></p> <ul style="list-style-type: none"> <li><input type="checkbox"/> <input type="checkbox"/> Turkish</li> <li><input type="checkbox"/> <input type="checkbox"/> Arabic</li> <li><input type="checkbox"/> <input type="checkbox"/> English</li> <li><input type="checkbox"/> <input type="checkbox"/> Reserve</li> </ul>
<p><b>BASEMENT SETTING</b></p>		<p><b>1 2</b></p> <ul style="list-style-type: none"> <li><input type="checkbox"/> <input type="checkbox"/> Basement 2</li> <li><input type="checkbox"/> <input type="checkbox"/> Basement 1</li> <li><input type="checkbox"/> <input type="checkbox"/> Basement</li> <li><input type="checkbox"/> <input type="checkbox"/> Entrance</li> </ul>
<p><b>MINUS FLOOR SETTING</b></p>		<p><b>1 2</b></p> <ul style="list-style-type: none"> <li><input type="checkbox"/> <input type="checkbox"/> -3</li> <li><input type="checkbox"/> <input type="checkbox"/> -2</li> <li><input type="checkbox"/> <input type="checkbox"/> -1</li> <li><input type="checkbox"/> <input type="checkbox"/> Entrance</li> </ul>
<p><b>BACKGROUND MUSIC SETTING</b></p>		<p><b>1 2</b></p> <ul style="list-style-type: none"> <li><input type="checkbox"/> <input type="checkbox"/> Play background music, announce last floor information</li> <li><input type="checkbox"/> <input type="checkbox"/> Play background music, not announce floor information</li> <li><input type="checkbox"/> <input type="checkbox"/> Not play background music, announce last floor information</li> <li><input type="checkbox"/> <input type="checkbox"/> Not playing background music, announce every floor information</li> </ul>



EEM Imp. Exp. Trade Co.  
Lift Control System

Tel: +90.332 346 46 56 - 66  
Fax: +90.332 346 46 76

www.eem.com.tr

Project Name	Gizmo+A3 Lift Control System		
Drawing Name	Set working parameter on SONIC announcement board		
Description	Version 2.00	Date 05.07.2015	Drawing No 19



Drawer HU  
Control BA

Page 23

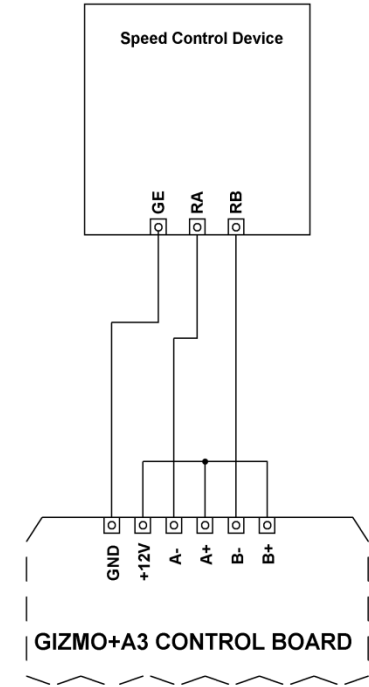
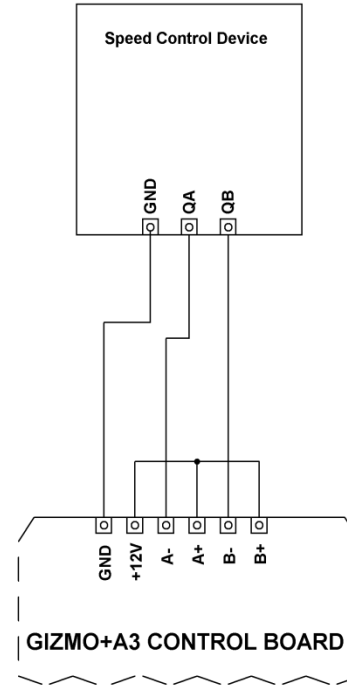
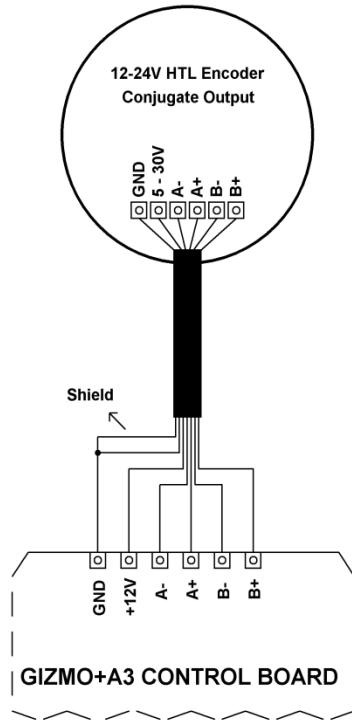
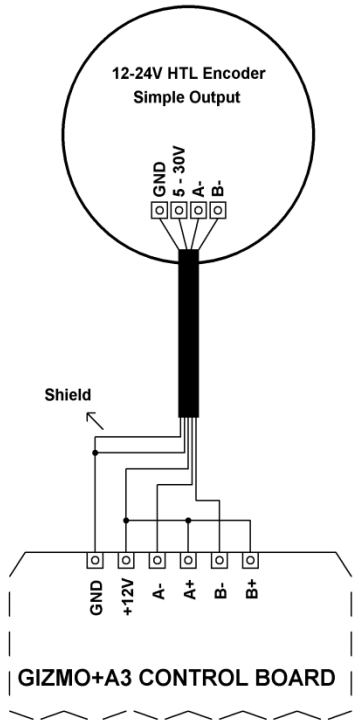

Note: Shielded helical cable (LIYCY) must be used. Signal terminals and 12V-GND terminals must be connected to helical cables.  
Cable shield must be connected to GND.

The calculation of Encoder Factor Parameter:

$$\text{Encoder Factor} = \frac{\text{Motor RPM} \times \text{Encoder Pulse}}{\text{Elevator Speed} \times 1000} \times 60$$

Example Calculation:

Motor RPM= 1500 RPM  
Encoder Pulse = 1024 pulse  
Elevator Speed= 1.5 m/s

$$\text{Encoder Factor} = \frac{1500 \times 1024}{1.5 \times 1000} = 17 \text{ (This value must be entered into "48-EncoderFactor" parameter)}$$

Note: In case encoder is connected to regulator, following values must be entered into "48-EncoderFactor" parameter.  
For 1024 pulse output encoder enter "1"  
For 500 pulse output encoder enter "0"



EEM Imp. Exp. Trade Co.  
Lift Control System

Tel: +90.332 346 46 56 - 66  
Fax: +90.332 346 46 76

www.eem.com.tr

Project Name Gizmo+A3 Lift Control System

Drawing Name Encoder Connection

Description

Version 2.00

Date 05.07.2015

Drawing No 20

Drawer HU  
Control BA



Page 24

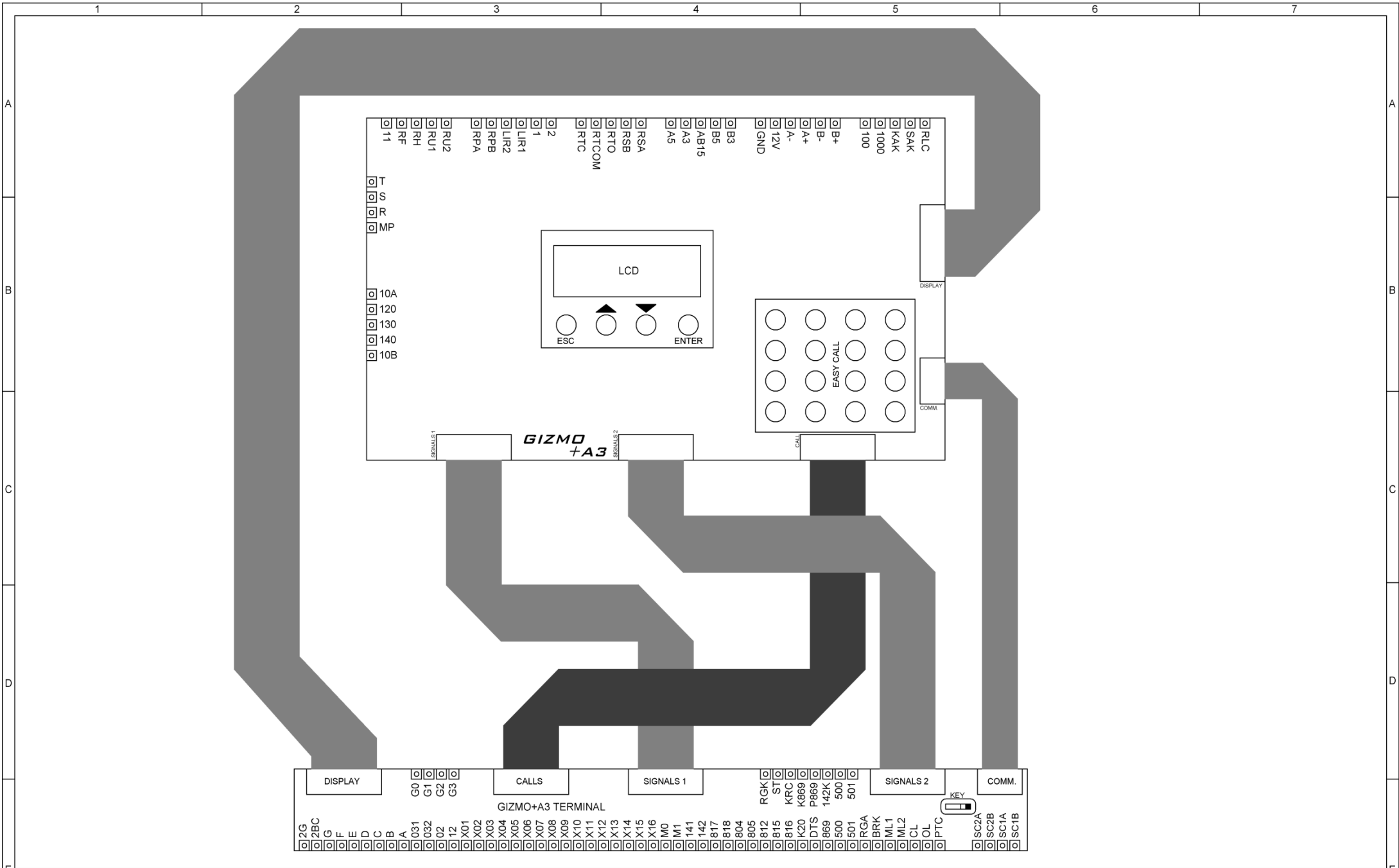

EEM Imp. Exp. Trade Co.  
Lift Control System

Tel: +90.332 346 46 56 - 66  
Fax: +90.332 346 46 76  
www.eem.com.tr

Project Name	Gizmo+A3 Lift Control System		
Drawing Name	GIZMO+A3 TERMINAL board flexible cable connection		
Description			Version 2.00
		Date 05.07.2015	Drawing No 21



Drawer HU
Control BA
Page 25

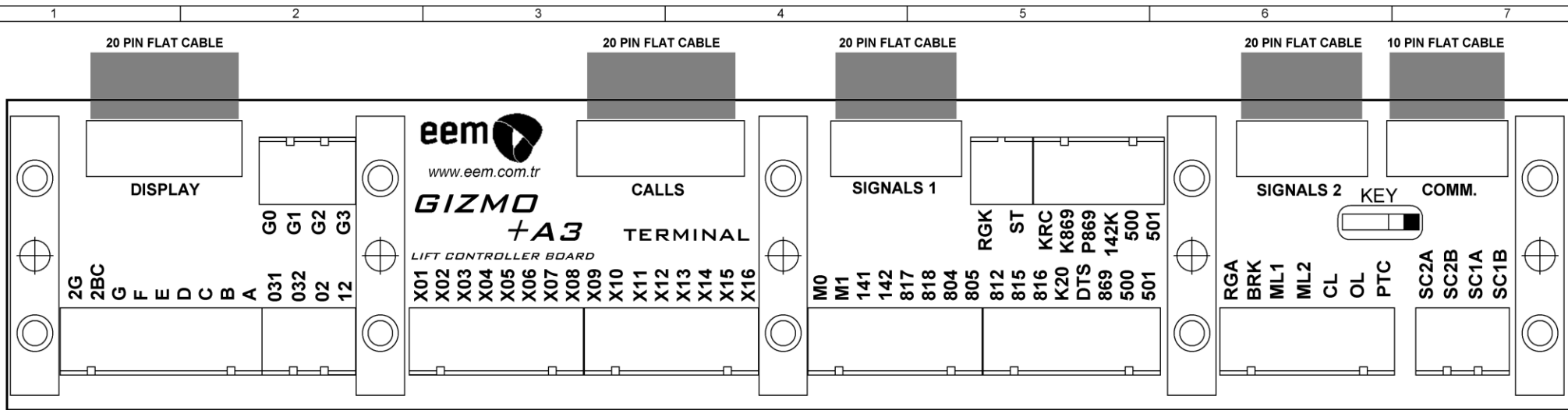

<b>A</b>	7 Segment Display A Signal (1000)
<b>B</b>	7 Segment Display B Signal (1000)
<b>C</b>	7 Segment Display C Signal (1000)
<b>D</b>	7 Segment Display D Signal (1000)
<b>E</b>	7 Segment Display E Signal (1000)
<b>F</b>	7 Segment Display F Signal (1000)
<b>G</b>	7 Segment Display G Signal (1000)
<b>2BC</b>	7 Segment Display 2BC Signal (1000)
<b>2G</b>	7 Segment Display 2G Signal (1000)
<b>031</b>	Down Arrow Signal (100 or 1000)
<b>032</b>	Up Arrow Signal (100 or 1000)
<b>02</b>	Out Of Service Signal (100 or 1000)
<b>12</b>	Busy Signal (100 or 1000)
<b>G0</b>	GRAY Code Signal (100)
<b>G1</b>	GRAY Code Signal (100)
<b>G2</b>	GRAY Code Signal (100)
<b>G3</b>	GRAY Code Signal (100)

<b>X01</b>	1. Stop Call Signal (100)
<b>X02</b>	2. Stop Call Signal (100)
<b>X03</b>	3. Stop Call Signal (100)
<b>X04</b>	4. Stop Call Signal (100)
<b>X05</b>	5. Stop Call Signal (100)
<b>X06</b>	6. Stop Call Signal (100)
<b>X07</b>	7. Stop Call Signal (100)
<b>X08</b>	8. Stop Call Signal (100)
<b>X09</b>	9. Stop Call Signal (100)
<b>X10</b>	10. Stop Call Signal (100)
<b>X11</b>	11. Stop Call Signal (100)
<b>X12</b>	12. Stop Call Signal (100)
<b>X13</b>	13. Stop Call Signal (100)
<b>X14</b>	14. Stop Call Signal (100)
<b>X15</b>	15. Stop Call Signal (100)
<b>X16</b>	16. Stop Call Signal (100)

<b>M0</b>	M0 Counter Bi-Stable Switch Connection (100)
<b>M1</b>	M1 Counter Bi-Stable Switch Connection (100)
<b>141</b>	JF1 Floor Slowdown Bi-Stable Switch Connection (100)
<b>142</b>	JF2 Floor Slowdown Bi-Stable Switch Connection (100)
<b>817</b>	Down Limit Stopper Bi-stable Switch Connection (100)
<b>818</b>	Upper Limit Stopper Bi-stable Switch Connection (100)
<b>804</b>	Overload Signal Connection (100)
<b>805</b>	Full Load Connection (100)
<b>812</b>	Watman Connection (100)
<b>815</b>	Quake Signal Connection (100)
<b>816</b>	Fire Signal Connection (100)
<b>K20</b>	Automatic Door Open Button, Photocell Thrust Force Contact Connection(100)
<b>DTS</b>	Automatic Door Close Button Connection (100)
<b>869</b>	Inspection Switch (100)
<b>500</b>	DOWN Moving Button Connection in Inspection Mode (100)
<b>501</b>	UP Moving Button Connection in Inspection Mode (100)
<b>KRC</b>	Contact Control (KRC) Connection (100)
<b>K869</b>	Inspection Well Connection (100)
<b>P869</b>	Inspection Panel Connection (100)
<b>142K</b>	(100)

<b>RGA</b>	Overspeed Governor Signal Connection (100)
<b>RGK</b>	Overspeed Governor Signal Connection (100)
<b>BRK</b>	Motor Brake Signal Connection (100)
<b>ST</b>	Determine Rescue Direction Signal Connection (100)
<b>ML1</b>	ML1 - ML2 Counter Mono-Stable Switch Signal(100)
<b>ML2</b>	ML1 - ML2 Counter Mono-Stable Switch Signal(100)
<b>CL</b>	Door Close Limit (100)
<b>OL</b>	Door Open Limit (100)
<b>PTC</b>	Motor Thermistor Connection (100)
<b>SC2A</b>	Group Operating Communication Line
<b>SC2B</b>	Group Operating Communication Line
<b>SC1A</b>	CARCOMM Car Communication Line
<b>SC1B</b>	CARCOMM Car Communication Line
<b>KEY</b>	Technical Service key connection port



EEM Imp. Exp. Trade Co.  
Lift Control System

Tel: +90.332 346 46 56 - 66  
Fax: +90.332 346 46 76

www.eem.com.tr

Project Name Gizmo+A3 Lift Control System  
Drawing Name TERMINAL connection board symbols

Description

Version 2.00

Date 05.07.2015

Drawing No 22

Page 26



Drawer HU  
Control BA



TÜRKAK  
TÜRK AKREDİTASYON KURUMU  
TURKISH ACCREDITATION AGENCY  
tarafından akredite edilmiştir.



EMC

Test ve Kontrol Hizmetleri San. Tic. A.Ş.

Hasköy Sanayi Sitesi İdari Bina No:13  
Gebze - KOCAELİ / TÜRKİYE

DENEY RAPORU

TESTING REPORT

AB-387-T

EMC 240

03.15

V.0

Cihazın Sahibi

Customer

EEM İTHALAT İHRACAT PAZARLAMA SAN. VE TİC. A.Ş.

Fevzi Çakmak Mah. Modesa San. Sit. 10735 Sokak No:3 Karatay / KONYA

İstek Numarası

Order Number

EMC 240 - 0315

Makine / Cihaz

Equipment

ASANSÖR KONTROL KARTI

Lift Control Board

Tip

Type

GIZMO A+3

İmalatçı

Manufacturer

EEM İTHALAT İHRACAT PAZARLAMA SAN. VE TİC. A.Ş.

Fevzi Çakmak Mah. Modesa San. Sit. 10735 Sokak No:3 Karatay / KONYA

Açıklamalar

Remarks

Numune Kabul Tarihi

Date of receipt

16.03.2015

Deney Tarihi

Date of Test

16.03.2015 - 17.03.2015

Raporun Sayfa Sayısı

Number of pages of the Report

31

Deney ve / veya ölçüm sonuçları, genişletilmiş ölçüm belirsizlikleri (olması halinde) ve deney metodları bu raporun tamamlayıcı kısmı olan takip eden sayfalarda verilmiştir.

The test and / or measurement results, the uncertainties (if applicable) with confidence probability and measurement methods are given on the following pages which are part of this report.

Bu rapor; firmamıza verilen numunelere uygulanan deney veya deneyler sonucunda hazırlanmıştır. Müşteriye ait diğer numuneleri kapsamaz.

This report was prepared after applying test / tests to the samples that are sent to our laboratory. Note that this report does not involve other samples of the customer.

Mühür ve Tarih

(Seal and Date)



18.03.2015

Deney Sorumlusu

(Person in Charge of Test)

Hakan ALTUN

Laboratuvar Müdürü

(Head of Laboratory)

Refik ALEMDAR

Bu rapor, laboratuvarın yazılı izni olmadan kısmen kopyalanıp çoğaltılamaz. İmzasız ve mühürsüz raporlar geçersizdir.

This report shall not be reproduced other than in full except with the permission of the laboratory. Test reports without signature and seal are not valid.

TF07 (Rev.02) 03.01.2012

SZUTEST TECHNICAL INSPECTION and CERTIFICATION

*Rely on Experience*



## ATTESTATION OF COMPLIANCE UYGUNLUK ONAYI

The technical file and test results of the following product has been checked and found in compliance with the essential requirements of European Parliament and Council Directive 2004/108/EC (EMC) of 15 December 2004 on the approximation of the laws of the Member States relating to electromagnetic compatibility.

*Teknik dosya ve test raporları incelenerek, belirtilen ürünün Avrupa Birliği Teknik Komisyonu tarafından 15 Aralık 2004 tarihinde yayınlanan 2004/108/AT Elektromanyetik Uyumluluk Yönetmeliğine uygunluğu saptanmıştır.*

**Applicant:**  
Başvuru Sahibi:

**EEM İth. İhr. Paz. ve Tic. A.Ş**  
Fevzi Çakmak Mah. MODESA Sanayi Sitesi 10735.Sok. No:3  
Karatay/KONYA/TÜRKİYE

**Manufacturer:**  
Üretici:

**EEM İth. İhr. Paz. ve Tic. A.Ş**  
Fevzi Çakmak Mah. MODESA Sanayi Sitesi 10735.Sok. No:3  
Karatay/KONYA/TÜRKİYE

**Product:**  
Ürün:

**Lift Controller Board**  
Asansör Kontrol Kartı

**Type/Model**  
Tip/Model

GIZMO+A3

**Base of attestation:**  
Onay Dayanağı:

File of technical documentation, test report of EMC Test ve Kontrol Hizmetleri A.Ş. EMC 240-0315.  
*Teknik Dökümantasyon, - EMC Test ve Kontrol Hizmetleri A.Ş. firmasına ait EMC 240-0315 numaralı Test Raporu.*

\* The referred technical file(s) is reviewed and attested with presumption of compliance with the essential requirements listed EU Directive(s) above. Other relevant Directives have to be observed. This attestation does not abrogate the compulsory obligation of the manufacturer to issue the declaration of conformity.

\*\* Product is not evaluated according to EN 81-1:1998+A3:2009 Annex F.6 and Annex F.8

\* Diğer ilgili direktiflere uyulmalıdır. Bu onay üreticinin uygunluk beyanı düzenleme zorunluluğunu ortadan kaldırmaz. Referans teknik dosya ile ürünün yukarıda belirtilen AT Direktiflerinin temel gereklerine uygunluğu kabul edilir.

\*\* Ürün EN 81-1:1998+A3:2009 EK F.6 ve EK F.8 şartlarına göre değerlendirilmemiştir.

Istanbul, Date/Tarih 2015-03-24  
Expiry Date: 2020-03-23



  
S. Oğuz Savaş  
Department Responsible



Dear Customer,

We, as EEM Co., Ltd. give utmost importance to the customer satisfaction. We are seeking your help about this. Please contribute developing our products by kindly spending a few minutes of your precious time to fill up this form and send it to us by post or fax. Thank you very much for your contribution.

❖ Please introduce us your firm?

Firm Name: \_\_\_\_\_ Contact Person \_\_\_\_\_  
 Address : \_\_\_\_\_

Tel : \_\_\_\_\_  
 Fax : \_\_\_\_\_

❖ What is your firm's area of interest?

- Installation  Electronic equipment for lifts  
 Equipment wholesale  Mechanical parts production  
 Control panel production  Other .....

❖ How did you hear about us?

- Fair  Internet  
 Advise  Magazine/Newspaper ads  
 Other .....

❖ Which products of ours have you used? Are you satisfied with our service?

Service\ Product	Rescuer	Control Card	Speed Control Eq.	Control Panel	Revision Set	Door Card
Sale	😊 😐 😞	😊 😐 😞	😊 😐 😞	😊 😐 😞	😊 😐 😞	😊 😐 😞
Price	😊 😐 😞	😊 😐 😞	😊 😐 😞	😊 😐 😞	😊 😐 😞	😊 😐 😞
Quality	😊 😐 😞	😊 😐 😞	😊 😐 😞	😊 😐 😞	😊 😐 😞	😊 😐 😞
Delivery	😊 😐 😞	😊 😐 😞	😊 😐 😞	😊 😐 😞	😊 😐 😞	😊 😐 😞
Installation	😊 😐 😞	😊 😐 😞	😊 😐 😞	😊 😐 😞	😊 😐 😞	😊 😐 😞
Technical Support	😊 😐 😞	😊 😐 😞	😊 😐 😞	😊 😐 😞	😊 😐 😞	😊 😐 😞
After Sale Service	😊 😐 😞	😊 😐 😞	😊 😐 😞	😊 😐 😞	😊 😐 😞	😊 😐 😞

😊 : Good    😐 : Medium    😞 : Bad

❖ Are you seeking for a new product, technical support or supplier firm?

Yes     No    Explanation:.....

❖ In your opinion, what are the two prime factors for a product? (Please make at most two choices.)

- Confidence     Easy Installation     Price     After Sales Service  
 Delivery Time     Technical Support



SENDER :

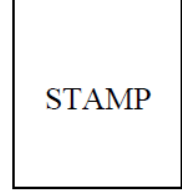

ADDRESS :

EEM İthalat İhracat Pazarlama ve Ticaret A.Ş  
Fevzi Çakmak Mah. MODESA Sanayi Sitesi 10735. Sok. No:3  
Karatay/KONYA/TURKIYE

Curve from here!

---

**eem**  
LIFT CONTROLLER and RESCUE SYSTEM



**EEM İTH. İHR. PAZ. ve TİC. AŞ.**

Tel: +90 332 346 46 56-66

Fax: +90 332 346 46 76

Fevzi Çakmak Mah.  
MODESA Sanayi Sitesi  
10735. Sok. No:3  
Karatay / Konya / Türkiye

[www.eem.com.tr](http://www.eem.com.tr)  
[bilgi@eem.com.tr](mailto:bilgi@eem.com.tr)