

# Gizmo User Manual

**eem**  
LIFT CONTROLLER and RESCUE SYSTEM



**“Beyond Usual Conditions”**



EEM IMP. EXP. TRADE CO.  
LIFT CONTROL SYSTEMS



# GIZMO

## LIFT CONTROLLER BOARD USER MANUAL



Serial Number:.....

Version: 3.20

NOTE: Make sure that the serial number of the user guide and the product is same. Otherwise, the product you use and the explanations given here may not match.

**CONNECTOR NUMBERS AND MEANINGS:**

10A	: Neutral of security circuit
120	: Stop return, Door contact start
130	: Door contact return, Lock start
140	: Lock return
11A	: Common terminal of Ru1/Rah, Ru2/Ryh, Rh/Ray, Rf/Ryy relays.
Ru1/Rah	: Terminal of down direction or down-fast relay.
Ru2/Ryh	: Terminal of up direction or up-fast relay.
Rh/Ray	: Terminal of fast or down-slow relay.
Rf/Ryy	: Terminal of slow or up-slow relay.
X2,R/Rx	: Normally opened (NO) terminals of Rx relay.
1, 2	: Normally open (NO) terminals of car lamp relay.
LO, LA	: Normally open(NO) terminals of pump relay.
NC1,COM1,NO1	: Normally opened (NO) and closed (NC) terminals of Rsvr relay.
K3	: Closing signal (Common terminal is K15)
K5	: Opening signal (Common terminal is K15)
K15	: Common terminal of K3-K5
K16	: Automatic door opening limit terminal (Common terminal is 100)
K19	: Automatic door closing limit terminal (Common terminal is 100)
9V – 9V	: Supply of 9V AC
100	: +24 Volts
1000	: Common terminal of 100 signal (-24 Volt)
a,b,c,d,e,f,g,2bc,2g	: Display outputs (Common terminal is 100)
02	: Out of service lamp (Common terminal is 1000)
12	: Busy lamp (Common terminal is 1000)
031	: Up direction arrow lamp (Common terminal is 1000)
032	: Down direction arrow lamp (Common terminal is 1000)
190	: Outer floor call common for simple control
Rrvd_a,Rrvd_b	:Normally opened(NO) terminals of Rrvd relay.(Note: Only use this relay for low current values)
M0,M1,M2,M3	: Bistable switch input (Common terminal is 100)
142	: JF precise stopper bistable floor switc (Common terminal is 100)
142K-142K	:JF bistable switch if rescuer is present in panel.(Common terminal is 100)
EY <sup>(1)</sup>	:Input of power cut information(Common terminal is 100)
OSB <sup>(1)(2)</sup>	: Auto leveling zone bistable switch.(Common terminal is 100)
JFA <sup>(1)(2)</sup>	: Down direction soft stopper bistable switch.(Common terminal is 100)
JFY <sup>(1)(2)</sup>	: Up direction soft stopper bistable switch.(Common terminal is 100)
817	: Lower limit stopper bistable switch (Common terminal is 100)
818	: Higher limit stopper bistable switch (Common terminal is 100)
819	: Lower and higher limit stopper switch for faster lifts than 1,0m/s speed.(Common terminal is 100)
804	: Over load contact (Common terminal is 100)
805	: Full load contact (Common terminal is 100)
812	: Cabin call Watman (Common terminal is 100)
815	: Earthquake contact (Common terminal is 100)
816	: Fire contact (Common terminal is 100)
K20	: Automatic door opening button, photocell contact, thrust force contact (Common terminal is 100)

## EEM Imp. Exp. Trade.Co. – Lift Control Systems

Fevzi Çakmak Mah. MODESA Sanayi Sitesi 10735. Sok .No:3 Karatay / KONYA / Türkiye  
Tel: +90 332 346 46 56-66 Fax: +90 332 346 46 76

DTS	: Automatic door closing button (Common terminal is 100)
867	: Cabin inspection switch (Common terminal is 100)
869	: Well inspection switch (Common terminal is 100)
500	: Inspection down button (Common terminal is 100)
501	: Inspection up button (Common terminal is 100)
KRC	: Contactor control signal input (Common terminal is 100)
PTC	: Motor termistor connection (Common terminal is 100)
X1-X16	: Call terminals (Common terminal is 100, signal common terminal is 1000)

(1): These inputs are properly active on “Hydraulic lifts” only.

(2): These inputs are properly active on “Hydraulic lifts”, “Rope lifts which have “door pre-opening” feature (integrated with ESP card) ” and “Rope VVVF lifts”.

**NOTE:** The default adjustment of the common terminals for low arrow, up arrow, busy and out of service lamps are 1000. The common terminal can be arranged as 100 from the jumpers over Gizmo.

### **CONTROL PANEL CONNECTOR NUMBERS AND MEANINGS:**

R,S,T	: Main Phases
Mp	: Neutral
PE	: Ground
U1,V1,W1	: High speed motor outputs for roped lifts, motor winding terminals for hydraulic lifts
U2,V2,W2	: Low speed motor outputs for roped lifts, motor winding terminals for hydraulic lifts
100	: +24 Volts
1000	: Common terminal of 100 signal (-24 Volt)
FR+,FR-	: Brake inductor terminals
PO+,PO-	: Pump inductor terminals
1F	: Direct Phase
1	: Direct phase over the cabin
2	: Cabin lamp
110	: Safety circuit start
111,112,113	: Null connectors
120	: Stop return, Door contact start
130	: Door contact return, Lock start
140	: Lock return
K3	: Closing signal (Common terminal is K15)
K5	: Opening signal (Common terminal is K15)
K15	: Common terminal of K3-K5
K16	: Automatic door opening limit terminal (Common terminal is 100)
K19	: Automatic door closing limit terminal (Common terminal is 100)
24+,24-	: 24V DC door opening voltage if rescue board is available in panel

**INDEX**

1) INTRODUCTION .....	6
2) FEATURES OF THE PRODUCT .....	6
3) LCD SCREEN AND KEYPAD .....	7
4) USE OF MENUS IN GIZMO LIFT CONTROL CARD .....	8
5) PARAMETERS .....	9
5-1) System Parameters .....	9
5-2) Rope Lift Application Macro .....	12
5-3) Rope VVVF Lift Application Macro .....	14
5-4) Star-Delta Hydrolic Lift Application Macro .....	16
5-5) Starter Hydrolic Lift Application Macro .....	18
6) OTHER FEATURES .....	28
7) FAULT CODES .....	29
8) FREQUENTLY ASKED QUESTIONS (FAQ) .....	32
9) IMPORTANT CONSIDERATIONS IN INSTALLATION OF THE PRODUCT .....	33
10) IMPORTANT CONSIDERATIONS IN CONNECTION OF CONTROL PANEL TO LIFT SYSTEM AND MAKING THE SYSTEM OPERATIONAL .....	34
10-1) Important Considerations in Connecting Control Panel to Lift system .....	34
10-2) Important Considerations on Preparing the System Become Operational .....	34
11) MAINTENANCE AND CLEANING OF GIZMOCONTROL CARD .....	35
12) SAFETY NOTICES .....	35
13) DRAWINGS & SCHEMES .....	36

## **EEM Imp. Exp. Trade.Co. – Lift Control Systems**

*Fevzi Çakmak Mah. MODESA Sanayi Sitesi 10735. Sok .No:3 Karatay / KONYA / Türkiye  
Tel: +90 332 346 46 56-66 Fax: +90 332 346 46 76*

---

Dear Customer,

Thank you for choosing Gizmo Board prepared based on the latest advancements of microelectronic systems. We would like to present you the best efficacy by our product that was manufactured in our modern facility and was carefully quality controlled. Therefore, we would like to request you to read this user guide thoroughly before starting installation and please keep it as a reference.

We give great care to ensure making installation and use of our product accurately and allow it to be in your service for long years. For this, we continuously update and extend our documets. All technical drawings are presented by carefully checking several times. However, should you notice any mistakes please do not hesitate to inform us. We will be in your service with newer and richer up-to-date versions.

Please follow our new products and updates at our web site [www.eem.com.tr](http://www.eem.com.tr) .

We hope you find our products to be a valuable tool in your business.

**ATTENTION !** : All documents given in this user manual are inteded for an advisory. Despite all our attention it may still contain mistakes and flaws. Please apply this information by controlling and throughly questioning.

## **1.INTRODUCTION**

GIZMO lift control card is a microcontroller based electronic lift control system. This board can be used to control both traction drive and hydrolic elevators. Also with addition of the special software, this card can be used to control the lifts which have no machine room and driven by stable magnet synchronised motors. Connector module that comes with GIZMO control card is used to connect control card connectors easily to control panel connectors. Fast call card allows calls during repair-maintenance of the lift easily and flawlessly.

## **2.FEATURES OF THE PRODUCT**

- Easy using and best performance for all type of lifts by different application macros of different lift types.
- Adjustable control type.
- Adjustable number of stops.
- Call inputs and stop capacities can be increased with card addition.
- Call lamps and buttons can be connected to the system with a single cable.
- All parameters can be adjusted easily using LCD screen and program buttons.
- Simple and error-free installation provides savings from time and number of control panel connectors.
- Short circuit protected display outputs having adjustable codes for every stop is available.
- Overload function is available.
- Full load function is present.
- Driver switch function is available.
- In case of fire, lift can be guided to a pre-defined stop.
- Adjustable parking stop and park travel time is available.
- For floor selector gray code and counter mode is available.
- Adjustable position reset function is available.
- In case of bistable switch faults, broken bistable switch can be detected easily.
- Auto reset feature of KRC fault, low-speed fault and hi-speed fault can be selected.
- Rlir relay can be programmed to be used in a different application.
- Programmable RX,Rrvd,Rlir,Rsvr relays for different using which aren't used on some type of applications.
- Warning function in LCD screen is available in case the door is left open for a long time.
- Adjustable busy time, wait time on the floor, lock wait time, door stay open time, door open error signal time, parking time, maximum high speed time and maximum low speed time features are present.
- For different types of buttons, display output type can be chosen as "a,b,c,d Segment", "Gray Code", "Reverse Gray", "Binary Code", "Reverse Binary".
- On the "Kartopu Serial Communication Card", display output type can be choosed as "a,b,c,d Segment", "Gray Code", "Reverse Gray", "Binary Code", "Reverse Binary".

- It can be operate in duplex mode.
- Auto-door type is eligible and Open/Closed standby mode for the fully automatic door can be adjusted. Also auto-door type can be chosen seperately for each floor. For example door type can be chosen as full automatic for ground and first floor, and it can be chosen as semiauto for garage floor. Also it can be chosen as “open on floor” for ground floor, “closed on floor” for first floor.
- Adjustable Rx time and drifting time for soft stop on the VVVF lifts.
- This card can properly run till 2,0m/s speed lifts.Number of neighbor stops can be adjusted. Different decelerate zones can be determined by Gizmo for neighbor calls and the others.
- Run properly with hydrolic lifts which is driven by “star-delta” or “soft-starter”.
- In star-delta hydrolic lifts; star-delta time, start-up valve delay, stopping motor delay, stopping valve delay can be adjusted individually.
- Adjustable soft starter contactor delay in soft starter hydrolic lifts.
- In roped or hydrolic lifts, door can operate on pre-opening mode with the addition of ESP card.
- In hydrolic lifts, door open leveling can be done with the additionof ESP card.
- In hydrolic lifts, rescuing can be done with UPS addition.
- It stores the latest 50 errors.
- All inputs and outputs can be tested on test menu.
- Turkish and English language options are present as standard feature.

### **3.LCD SCREEN AND KEYPAD**

GIZMO lift control card includes two line 16 character LCD screen and four push-buttons designated as ENTER, ESC, UP and DOWN keys.

EEM Engineering  
GIZMO Mainboard

When the system is powered, LCD screen displays messages named “Initialize Screen”. In the first message, our firm and product names are displayed. Afterwards the version number of the product is displayed. In the third message, the serial number of the card used is shown. Each of these screens are displayed for one second and then the screen called “Main screen” is displayed

EEM Engineering  
sn:01x195

Main screen displays that lift waits for an entry and also transformer voltage feeding control signals are shown. On this screen, “c” denotes the stop where the Cabin is located and “t” denotes the Target stop of the cabin.

AwaitingRecord  
c01→t-- AC=25V

For example, while the cabin is located in the 1<sup>st</sup> stop, if it gets an entry for 5<sup>th</sup> stop, after the lift starts moving, the screen shown on the left side is displayed.

UP FAST  
c01→t05 AC=25V

#### **4.USE OF MENUS IN GIZMO LIFT CONTROL CARD**

In GIZMO lift control card all parameters have been grouped and numbered. Hence, reaching any parameter, displaying its value and making changes are extremely easy.

\*\*\* MAIN MENU \*\*\*

1-WellSettings

When GIZMO is in standby mode in main screen, menu is entered by pressing ENTER key for 3 seconds. Here, the screen shown in the left side is displayed. User can browse in main menu by using UP and DOWN keys. ENTER key can be pressed to enter in the desired parameter group.

2.1-BusyTime  
8 seconds

For example, to enter in the 2<sup>nd</sup> parameter group, when ENTER key is pressed, the first one of the 2<sup>nd</sup> parameter group “2.1-Busy Time” parameter is displayed as shown in the left. Similarly, other parameters can be browsed using UP and DOWN buttons. To change the parameter, desired parameter is chosen by pressing ENTER button.

2.1-BusyTime  
> 8 seconds

When ENTER key is pressed a right ARROW sign is displayed on the screen. Now, it is possible to change this parameter using UP and DOWN keys. Pressing ENTER key confirms the changes or ESC key can be pressed to cancel the changes and current menu is exited. The ARROW sign disappears and the changes you have made is immediately stored and activated. Similarly, after all necessary adjustments have been made; menu can be exited by pressing ESC key.

## 5.PARAMETERS

A large number of adjustable parameters are provided to the user to meet demands of lifts in the field. Because many number of parameters exist, for ease of use, they have been classified in terms of their characteristics and functions. Parameter list is shown below.

### 5.1. System Parameters

Gizmo Control Card provides high quality features to the user by presenting different application macros of different lift types. The constant system parameters are conceived as follows.

Par. No	Parameter Name	Setting Field	Default Settings	Explanations
<b>7.REPORTS</b>				
7.1	Faults		-	The number of the latest occurred fault is 1.
7.2	Erase Faults		-	
<b>8.SYSTEM INFORMATION</b>				
8.2	Versiyon Number		-	
8.3	Serial Number		-	
8.4	Manufacturer Info		-	
8.5	Dealer Info		-	
<b>9.GIZMO TEST MENU</b>				
9.1	Input Test		-	The ordering of the information on the screen and general purpose inputs are same.
9.2	Call Test		-	
9.3	Expansion Call Test		-	It operates in connection with control type and number of stops. If even the expansion call card is connected and control type and the number of stops was set correctly, testing of the expansion call card is not possible.
9.4	Relay Test		-	To enter into menu, the lift must be taken to inspection and stop button must be pressed. Also, if KRC signals are cut for any reason, bu menu is automatically exited.
<b>10.SECURITY</b>				
10.1	PIN Code Request	On	Off	
10.2	PIN Changing		-	This menu is not displayed if code inquiry is off.
<b>11.RETURN TO DEFAULT SETTINGS</b>				
11.1	Roped Lift		-	
11.2	Roped VVVF		-	
11.3	Star/Delta Hydrolic		-	
11.4	Soft Starter Hydrolic		-	
<b>12.LANGUAGE</b>				
12	Language - Dil	English-Turkish	Turkish	

----- SYSTEM PARAMETERS -----

## P7-REPORTS

7.1-Faults F=01  
F1.StopFault

**7.1-Faults:** Previously occurred 50 faults can be seen here. The number of the latest fault is 1 and the number of the first fault is 50. When more than 50 faults occur, the earliest occurred fault is lost.

7-Reports  
7.2-EraseFaults

**7.2-Erase faults:** It can be used to erase the recorded faults from the memory.

## P8-SYSTEM INFORMATION

8-SystemInfo  
8.2-VersionNumber

**8.2-Version Number:** Version number of the software can be seen from this parameter.

8-SystemInfo  
8.3-SerialNumber

**8.3-Serial Number:** Serial number of the product can be seen from this parameter.

8-SystemInfo  
8.4-ManufacturerInfo

**8.4-Manufacturer Information:** The communication information of the manufacturer EEM Imp. Exp. Trade Co. can be seen from this parameter. Other communication data can be obtained by using updown buttons inside this parameter.

8-SystemInfo  
8.5-DealerInfo

**8.5-Dealer Information:** The communication information of the authorized seller firm on your area can be seen from this parameter. Other communication data can be obtained by using up-down button inside this parameter.

## P9-TEST MENU

9-TestMenu  
9.1-InputTest

**9.1-Input Test:** 20 general purpose inputs located just below the LCD screen can be tested by this parameter. SFK is the abbreviation for stop, door contact and lock. 110 data just below the SFK abbreviation implies that stop and door contact are energized and lock is not. The numbers lying in two lines located on the right hand side represent 20 inputs located below the LCD screen, which is ordered from left to right, i.e. the first info on the upper line represent M0 and the second one represent M1. Therefore, all inputs whether they can be sensed by microcontroller or not can be tested.

SDL 01001-00011  
110 11010-10010

**9.2-Call Test:** The inputs coming from call buttons can be tested by this parameter. The information seen on the screen represents call inputs in the ordered way. The first character on the upper line represents the first one of the call inputs located on Gizmo. Therefore, all calls whether they can be sensed by microcontroller or not can be tested.

9-TestMenu  
9.2-CallTest

0100-0000  
0000-0001

**9.3-Expansion Call Test:** If an expansion call card connected to Gizmo is present, the inputs on this card can be tested by this parameter. The information seen on the screen represents expansion call inputs in the ordered way.

9-TestMenu  
9.3-ExpansionCallTest

NOTE: If control type and stop number parameters was set in a way that an expansion call card is not required, testing the expansion call card is not possible.

**9-TestMenu**  
**9.4-RelayTest**

**9.4-Relay Test:** All relays placed on Gizmo can be tested by this parameter. To prevent an undesired motion of the lift, before starting test process, emergency stop button must be pressed and the lift must be taken to the inspection. When these conditions are satisfied, R31 relay is instantly switched on. Using up and down buttons, switching the relays on and off one by one is possible. However, at the moment a relay is switched on, if KRC signal is cut off (i.e. contactor is released), for safety, all relays are automatically switched off and the menu is exited.

**P10-SECURITY**

**10.1-PIN CodeRequest Off**

**10.1-PIN Code Request:** Password query can be activated by this parameter to ensure no unauthorized person to get access to Gizmo, observe parameters and modifying them.If password query is enabled, the password must be correctly submitted to disable it. NOTE: When password query was disabled and enabled again the former password is valid. For that reason, even if you disable password query, don't forget it. The factory default of the password is "000000".

NOTE: If you submit wrong password 5 times, Gizmo blocks itself. Sytem goes on operating but parameter access is prevented. After your password is blocked, a key number is seen on the screen. Call EEM Ltd.Co. and notify us this key number. You can reactivate the card by entering Gizmo the number provided to you.

**10.2-PIN Changing**

**10.2-PIN Changing:** This menu can only be displayed if password query is enabled. When you wanted to change the password, your old password is asked. Then you submit your new password. For approval, Gizmo asks for the new password again. Then, "PasswordChanged" message is displayed on the screen. Your new password is now active.

**P11-RETURN TO DEFAULTS**

**11-ReturnToDefaults**  
**11.1-RopeLift**

- Rope Lift
- Rope VVVF Lift
- Star Delta – Hydrolic Lift
- Soft Starter – Hydrolic Lift

In Gizmo control card, the type of the lift can only be chosen by returning to defaults. Hence, hidden menus are also activated. For example, in roped lifts Rx time, star delta time is not displayed. Rx time can only be displayed for roped vvvf lifts and star delta time for star delta hydrolic lifts.

## P12-LANGUAGE - DİL

11-Language - Dil  
English

Gizmo control card standartyly supports Turkish and English languages. Please contact the manufacturer for other language demands.

### 5.2. Rope Lift Application Macro

If the lift type is selected as “Rope Lift”, the application macro which is prepared for rope lifts turns on. In this macro, parameters below are activated.

Par. No	Parameter Name	Setting Field	Default Settings	Explanations
<b>1.WELL SETTINGS</b>				
1.1	Lift Type	-	Rope Lift	Only displayable, not changeable. To make a change, look for 11.th group parameters.
1.2	Control Type	Simple Collective Complex Collective One button down collective One button up collective One button full collective Two button full collective	Complex Collective	For connection principle have a look at the drawings numbered 6x.
1.3	Car Communication	Serial Parallel	Parallel	
1.4	Button Communication	Serial Parallel	Parallel	
1.5	Lift Groups	Simplex Duplex A Duplex B	Simplex	
1.6	Auto Door	None Semi Automatic Full Automatic Full Automatic, Open at the Floor Special Door	Semi Automatic	
1.7	Special Door		-	This parameter can be displayed only if the type of door was set as <b>special door</b> .
1.8	Door Pre-Opening	Yes No	No	
<b>2.TIMES</b>				
2.1	Busy Time	1 ~ 20 seconds	8 seconds	
2.2	Wait Time At Stops	1 ~ 15 seconds	4 seconds	
2.3	Lock Wait Time	5 ~ 25 seconds	15 seconds	
2.4	Door Stay Opened Time	1 ~ 40 seconds	6 seconds	This parameter can be displayed only if the type of door was set as <b>full auto</b> or <b>special door</b> .
2.5	Open Door Fault Time	10 ~ 240 seconds	60 seconds	
2.6	Parking Time	20 ~ 250 seconds	30 seconds	This parameter can be displayed only if “ <b>3.6-Parking Stop</b> ” parameter was set as unlike
2.7	Slow Travel Time	5 ~ 20 seconds	10 seconds	
2.8	Fast Travel Time	10 ~ 100 seconds	15 seconds	

\*\*\*ROPE LIFT APPLICATION MACRO\*\*\*

## EEM Imp. Exp. Trade.Co. – Lift Control Systems

Fevzi Çakmak Mah. MODESA Sanayi Sitesi 10735. Sok .No:3 Karatay / KONYA / Türkiye

Tel: +90 332 346 46 56-66 Fax: +90 332 346 46 76

3.STOP SETTINGS				
3.1	Number Of Stops	2~16 stops	16	
3.2	Display Output Type	7 Segment Display Gray Code Inverted Gray Binary Code Inverted Binary	7 Segment Display	
3.3	Serial Communication Card Display Output Type	7 Segment Display Gray Code Inverted Gray Binary Code Inverted Binary	7 Segment Display	This parameter can be displayed only if "1.3-Car Comm." parameter was set as <b>serial</b> .
3.4	Display Settings		-	This parameter can be displayed only if one of "3.2-Display Output Type" or "3.3-Serial Comm.Display Output Type" parameter was set as "7 segment display". Also stops that adjusted by "3.1 Number Of Stops" can be adjusted only.
3.5	Fire Stop	Cancel, 1~16 stops	Cancel	
3.6	Parking Stop	Cancel, 1~16 stops	Cancel	You can adjust the parking time by "2.6-Parking Time" parameter.
4.SHAFT INFO				
4.1	Sensor Type	Gray Code Counter	Gray Code	For lifts with door pre-opening function enabled, as the default setting for cabin position sense is "counter", this parameter can not be displayed for these conditions.
4.2	Position Reset	Yes No	No	This parameter can be displayed only if the sensor type is "counter".
5.OTHER SETTINGS				
5.1	Auto Reset KRC	Yes No	No	
5.2	Auto Reset Max Low Speed Time Fault	Yes No	No	
5.3	Auto Reset Max High Speed Time Fault	Yes No	No	
5.4	Rx Relay	Cancel Inspection Gong Error Lift Functions Lir	Cancel	
5.5	Rlir Relay	Cancel Inspection Gong Error Lift Functions Lir	-	This parameter can be displayed if the type of door was set as "full auto", "full auto-open at floor" or "special door". Otherwise, this relay run as a <b>Rlir (Pomp)</b> relay.
5.6	Rsvr Relay	Cancel Inspection Gong Error Lift Functions Lir	Cancel	
5.7	Rrvd Relay	Cancel Inspection Gong Error Lift Functions	Cancel	Don't use this relay for high current values. We suggest you to use it for only at a current value that turns on only one relay.
5.11	Stop Clear Call	Yes No	Yes	

\*\*\*ROPE LIFT APPLICATION MACRO\*\*\*

\*\*\*ROPE LIFT APPLICATION MACRO\*\*\*

### 5.3. Rope VVVF Lift Application Macro

If the lift type is selected as “Rope VVVF Lift”, the application macro which is prepared for speed controlled lifts turns on. In this macro, parameters below are activated.

Par. No	Parameter Name	Setting Field	Default Settings	Explanations
<b>1.WELL SETTINGS</b>				
1.1	Lift Type	-	Rope VVVF Lift	Only displayable, not changeable. To make a change, look for 11.th group parameters.
1.2	Control Type	Simple Collective Complex Collective One button down collective One button up collective One button full collective Two button full collective	Complex Collective	For connection principle have a look at the drawings numbered 6x.
1.3	Car Communication	Serial Parallel	Parallel	
1.4	Button Communication	Serial Parallel	Parallel	
1.5	Lift Groups	Simplex Duplex A Duplex B	Simplex	
1.6	Auto Door	None Semi Automatic Full Automatic Full Automatic, Open at the Floor Special Door	Semi Automatic	
1.7	Special Door		-	This parameter can be displayed only if the type of door was set as <b>special door</b> .
1.8	Door Pre-Opening	Yes No	No	
<b>2.TIMES</b>				
2.1	Busy Time	1 ~ 20 seconds	8 seconds	
2.2	Wait Time At Stops	1 ~ 15 seconds	4 seconds	
2.3	Lock Wait Time	5 ~ 25 seconds	15 seconds	
2.4	Door Stay Opened Time	1 ~ 40 seconds	6 seconds	This parameter can be displayed only if the type of door was set as <b>full auto</b> or <b>special door</b> .
2.5	Open Door Fault Time	10 ~ 240 seconds	60 seconds	
2.6	Parking Time	20 ~ 250 seconds	30 seconds	This parameter can be displayed only if “ <b>3.6-Parking Stop</b> ” parameter was set as unlike
2.7	Slow Travel Time	5 ~ 20 seconds	10 seconds	
2.8	Fast Travel Time	10 ~ 100 seconds	15 seconds	
<b>3.STOP SETTINGS</b>				
3.1	Number Of Stops	2~16 stops	16	
3.2	Display Output Type	7 Segment Display Gray Code Inverted Gray Binary Code Inverted Binary	7 Segment Display	

\*\*\*ROPE VVVF LIFT APPLICATION MACRO\*\*\*

## EEM Imp. Exp. Trade.Co. – Lift Control Systems

Fevzi Çakmak Mah. MODESA Sanayi Sitesi 10735. Sok .No:3 Karatay / KONYA / Türkiye

Tel: +90 332 346 46 56-66 Fax: +90 332 346 46 76

***ROPE VVVF LIFT APPLICATION MACRO***	3.3	Serial Communication Card Display Output Type	7 Segment Display Gray Code Inverted Gray Binary Code Inverted Binary	7 Segment Display	This parameter can be displayed only if “ <b>1.3-Car Comm.</b> ” parameter was set as <b>serial</b> .	
	3.4	Display Settings		-	This parameter can be displayed only if one of “ <b>3.2-Display Output Type</b> ” or “ <b>3.3-Serial Comm.Display Output Type</b> ” parameter was set as “ <b>7 segment display</b> ”. Also stops that adjusted by “ <b>3.1 Number OfStops</b> ” can be adjusted only.	
	3.5	Fire Stop	Cancel, 1~16 stops	Cancel		
	3.6	Parking Stop	Cancel, 1~16 stops	Cancel	You can adjust the parking time by “ <b>2.6-Parking Time</b> ” parameter.	
	<b>4.SHAFT INFO</b>					
	4.1	Sensor Type	Gray Code Counter	Gray Code	For lifts with door pre-opening function enabled, as the default setting for cabin position sense is “ <b>counter</b> ”, this parameter can not be displayed for these conditions.	
	4.2	Position Reset	Yes No	No	This parameter can be displayed only if the sensor type is “ <b>counter</b> ”.	
	4.3	Neighbor Stops Number	Cancel, 1~16 stops	Cancel		
	<b>5.OTHER SETTINGS</b>					
	5.1	Auto Reset KRC	Yes No	No		
	5.2	Auto Reset Max Low Speed Time Fault	Yes No	No		
	5.3	Auto Reset Max High Speed Time Fault	Yes No	No		
	5.4	Rx Relay	Cancel Inspection Gong Error Lift Functions Lir	Cancel		
5.5	Rlir Relay	Cancel Inspection Gong Error Lift Functions Lir	-	This parameter can be displayed if the type of door was set as “ <b>full auto</b> ”, “ <b>full auto-open at floor</b> ” or “ <b>special door</b> ”. Otherwise, this relay run as a <b>Rlir (Pomp)</b> relay.		
5.6	Rsvr Relay	Cancel Inspection Gong Error Lift Functions Lir	Cancel			
5.7	Rrvd Relay	Cancel Inspection Gong Error Lift Functions	Cancel	Don't use this relay for high current values. We suggest you to use it for only at a current value that turns on only one relay.		
5.11	Stop Clear Call	Yes No	Yes			

### 5.4. Star-Delta Hydraulic Lift Application Macro

If the lift type is selected as “Star-Delta Hydraulic Lift”, the application macro which is prepared for hydraulic lifts which are driven by star-delta method, turns on. In this macro, parameters below are activated.

Par. No	Parameter Name	Setting Field	Default Settings	Explanations
<b>1.WELL SETTINGS</b>				
1.1	Lift Type	-	Rope Lift	Only displayable, not changeable. To make a change, look for 11.th group parameters.
1.2	Control Type	Simple Collective Complex Collective One button down collective One button up collective One button full collective Two button full collective	Complex Collective	For connection principle have a look at the drawings numbered 6x.
1.3	Car Communication	Serial Parallel	Parallel	
1.4	Button Communication	Serial Parallel	Parallel	
1.5	Lift Groups	Simplex Duplex A Duplex B	Simplex	
1.6	Auto Door	None Semi Automatic Full Automatic Full Automatic, Open at the Floor Special Door	Semi Automatic	
1.7	Special Door		-	This parameter can be displayed only if the type of door was set as <b>special door</b> .
1.8	Door Pre-Opening	Yes No	No	
1.9	Relevelling WithOpen Doors	Yes No	No	
<b>2.TIMES</b>				
2.1	Busy Time	1 ~ 20 seconds	8 seconds	
2.2	Wait Time At Stops	1 ~ 15 seconds	4 seconds	
2.3	Lock Wait Time	5 ~ 25 seconds	15 seconds	
2.4	Door Stay Opened Time	1 ~ 40 seconds	6 seconds	This parameter can be displayed only if the type of door was set as <b>full auto</b> or <b>special door</b> .
2.5	Open Door Fault Time	10 ~ 240 seconds	60 seconds	
2.6	Parking Time	20 ~ 250 seconds	30 seconds	This parameter can be displayed only if “ <b>3.6-Parking Stop</b> ” parameter was set as unlike
2.7	Slow Travel Time	5 ~ 20 seconds	10 seconds	
2.8	Fast Travel Time	10 ~ 100 seconds	15 seconds	
2.60	Star Delta Time	0.0 ~5.0 seconds	0.6 seconds	
2.61	Valve Delay At Running	0.0 ~5.0 seconds	0.5 seconds	
2.62	Motor Delay At Stopping	0.0 ~5.0 seconds	0.4 seconds	
2.64	Valve Delay At Stopping	0.0 ~5.0 seconds	0.0 seconds	

## EEM Imp. Exp. Trade.Co. – Lift Control Systems

Fevzi Çakmak Mah. MODESA Sanayi Sitesi 10735. Sok .No:3 Karatay / KONYA / Türkiye  
Tel: +90 332 346 46 56-66 Fax: +90 332 346 46 76

3.STOP SETTINGS				
3.1	Number Of Stops	2~16 stops	16	
3.2	Display Output Type	7 Segment Display Gray Code Inverted Gray Binary Code Inverted Binary	7 Segment Display	
3.3	Serial Communication Card Display Output Type	7 Segment Display Gray Code Inverted Gray Binary Code Inverted Binary	7 Segment Display	This parameter can be displayed only if "1.3-Car Comm." parameter was set as <b>serial</b> .
3.4	Display Settings		-	This parameter can be displayed only if one of "3.2-Display Output Type" or "3.3-Serial Comm.Display Output Type" parameter was set as "7 segment display". Also stops that adjusted by "3.1 Number Of Stops" can be adjusted only.
3.5	Fire Stop	Cancel, 1~16 stops	Cancel	
3.6	Parking Stop	Cancel, 1~16 stops	Cancel	You can adjust the parking time by "2.6-Parking Time" parameter.
4.SHAFT INFO				
4.2	Position Reset	Yes No	No	This parameter can be displayed only if the sensor type is "counter".
5.OTHER SETTINGS				
5.1	Auto Reset KRC	Yes No	No	
5.2	Auto Reset Max Low Speed Time Fault	Yes No	No	
5.3	Auto Reset Max High Speed Time Fault	Yes No	No	
5.5	Rlir Relay	Cancel Inspection Gong Error Lift Functions Lir	-	This parameter can be displayed if the type of door was set as "full auto", "full auto-open at floor" or "special door". Otherwise, this relay run as a <b>Rlir (Pomp)</b> relay.
5.11	Stop Clear Call	Yes No	Yes	

\*\*\*STAR-DELTA HYDRAULIC LIFT APPLICATION MACRO\*\*\*

### 5.5. Soft Starter Hydraulic Lift Application Macro

If the lift type is selected as “Soft Starter Hydraulic Lift”, the application macro which is prepared for hydraulic lifts which are driven by soft-starter method, turns on. In this macro, parameters below are activated.

Par. No	Parameter Name	Setting Field	Default Settings	Explanations
<b>1.WELL SETTINGS</b>				
1.1	Lift Type	-	Rope Lift	Only displayable, not changeable. To make a change, look for 11.th group parameters.
1.2	Control Type	Simple Collective Complex Collective One button down collective One button up collective One button full collective Two button full collective	Complex Collective	For connection principle have a look at the drawings numbered 6x.
1.3	Car Communication	Serial Parallel	Parallel	
1.4	Button Communication	Serial Parallel	Parallel	
1.5	Lift Groups	Simplex Duplex A Duplex B	Simplex	
1.6	Auto Door	None Semi Automatic Full Automatic Full Automatic, Open at the Floor Special Door	Semi Automatic	
1.7	Special Door		-	This parameter can be displayed only if the type of door was set as <b>special door</b> .
1.8	Door Pre-Opening	Yes No	No	
1.9	Relevelling WithOpen Doors	Yes No	No	
<b>2.TIMES</b>				
2.1	Busy Time	1 ~ 20 seconds	8 seconds	
2.2	Wait Time At Stops	1 ~ 15 seconds	4 seconds	
2.3	Lock Wait Time	5 ~ 25 seconds	15 seconds	
2.4	Door Stay Opened Time	1 ~ 40 seconds	6 seconds	This parameter can be displayed only if the type of door was set as <b>full auto</b> or <b>special door</b> .
2.5	Open Door Fault Time	10 ~ 240 seconds	60 seconds	
2.6	Parking Time	20 ~ 250 seconds	30 seconds	This parameter can be displayed only if “ <b>3.6-Parking Stop</b> ” parameter was set as unlike
2.7	Slow Travel Time	5 ~ 20 seconds	10 seconds	
2.8	Fast Travel Time	10 ~ 100 seconds	15 seconds	
2.60	Star Delta Time	0.0 ~5.0 seconds	0.5 seconds	
2.61	Valve Delay At Running	0.0 ~5.0 seconds	0.4 seconds	
2.63	Soft Starter Contactor Delay	0.0 ~5.0 seconds	1.0 seconds.	
2.64	Valve Delay At Stopping	0.0 ~5.0 seconds	0.0 seconds	

## EEM Imp. Exp. Trade.Co. – Lift Control Systems

Fevzi Çakmak Mah. MODESA Sanayi Sitesi 10735. Sok .No:3 Karatay / KONYA / Türkiye

Tel: +90 332 346 46 56-66 Fax: +90 332 346 46 76

3.STOP SETTINGS				
3.1	Number Of Stops	2~16 stops	16	
3.2	Display Output Type	7 Segment Display Gray Code Inverted Gray Binary Code Inverted Binary	7 Segment Display	
3.3	Serial Communication Card Display Output Type	7 Segment Display Gray Code Inverted Gray Binary Code Inverted Binary	7 Segment Display	This parameter can be displayed only if "1.3-Car Comm." parameter was set as <b>serial</b> .
3.4	Display Settings		-	This parameter can be displayed only if one of "3.2-Display Output Type" or "3.3-Serial Comm.Display Output Type" parameter was set as "7 segment display". Also stops that adjusted by "3.1 Number Of Stops" can be adjusted only.
3.5	Fire Stop	Cancel, 1~16 stops	Cancel	
3.6	Parking Stop	Cancel, 1~16 stops	Cancel	You can adjust the parking time by "2.6-Parking Time" parameter.
4.SHAFT INFO				
4.2	Position Reset	Yes No	No	This parameter can be displayed only if the sensor type is "counter".
5.OTHER SETTINGS				
5.1	Auto Reset KRC	Yes No	No	
5.2	Auto Reset Max Low Speed Time Fault	Yes No	No	
5.3	Auto Reset Max High Speed Time Fault	Yes No	No	
5.5	Rlir Relay	Cancel Inspection Gong Error Lift Functions Lir	-	This parameter can be displayed if the type of door was set as "full auto", "full auto-open at floor" or "special door". Otherwise, this relay run as a <b>Rlir (Pomp)</b> relay.
5.11	Stop Clear Call	Yes No	Yes	

\*\*\*SOFT STARTER HYDRAULIC LIFT APPLICATION MACRO\*\*\*

## P1-WELL SETTINGS

### 1.1-LiftType RopeLift

**1.1-Type of Lift:** The type of lift previously set can be seen from this parameter and it is not user changeable. The type of lift can be changed by adjusting 11th group parameters to factory default settings.

### 1.2-ControlType ComplexCollective

**1.2-Control Type:** The control type of the lift can be chosen by this parameter.

#### Simple Control Complex Collective

: Only one record is taken.

: Floor calls and cabin terminals are wired to the same connector. If the common of outer calls are taken from 190, no collecting is done for outer calls. Collecting is done only for the inner car.

#### 1 Button Down Collective

: For floor calls, the lift stops only for down travel direction.

#### 1 Button Up Collective

: For floor calls, the lift stops only for up travel direction.

#### 1 Button Full Collective

: For floor calls the lift stops for both directions.

#### 2 Buttons Collective

: On each floor, two call buttons are available.

Car Communication : Parallel		
Control Type	Max. Stops Numbers Without Expansion Card	Max. Stops Numbers With Expansion Card
Simple Collective	16	-
Complex Collective	16	-
1 Button Down Collective	8	16
1 Button Up Collective	8	16
1 Button Full Collective	8	16
2 Buttons Collective	6	11

Car Communication : Serial		
Control Type	Max. Stops Numbers Without Expansion Card	Max. Stops Numbers With Expansion Card
Simple Collective	16	-
Complex Collective	16	-
1 Button Down Collective	16	-
1 Button Up Collective	16	-
1 Button Full Collective	16	-
2 Buttons Collective	9	16

**1.3-CarComm.  
Parallel**

**1.3-Cabin Communication:** The connection type between control card and cabin can be set through this parameter.

- Parallel : A one-to-one connection is done between control card and all buttons and sensors in the cabin.
- Serial : A serial connection between control card and cabin is done through serial communication card. Thus, saving from flexible cable is provided.

**1.4-ButtonComm.  
Parallel**

**1.4-Button Communication:** It determines the communication type between floor buttons.

- Parallel : A one-to-one connection is done between control card and all buttons and signals on the floor.
- Serial : A connection through serial cable is done between control card and all buttons and signals on the floor.

**1.5-LiftGroups  
Simplex**

**1.5-Lift Groups:** This parameter determines the lift groups.

- Simplex : Control panel functions privately.
- Duplex A Panel : In double group operation, it functions as decider (master) panel.
- Duplex B Panel : In double group operation, it operates as 2nd (slave) panel.

**1.6-AutoDoor  
Full Automatic**

**1.6- Automatic Door:** This parameter determines the type of the automatic door.

- None : This parameter is set if the lift has only swing door.
  - Semi Automatic : The lift has only security door in cabin and has only swing door on floor.
  - Full Automatic : The lift has fully automatic floor and cabin doors.
  - Full Automatic Open At Floor: This parameter is used for the case where the lift has full automatic floor and cabin doors and full automatic door is desired to be standing open on the floor.
  - Special Door : At Gizmo, all doors at stops can be adjusted as “Semi Auto” or “Full Auto” or “Full Auto-Open” for per floors individually. To make this adjust, this parameter must be selected as “Special Door” at first, and then all doors must be adjusted individually for all floors.
- WARNING ! :** For the conformity to EN81-1/2 directives, the fully automatic door MUST be adjusted to be closed on the floor. This parameter was intended for the countries which are not bound to EU standards.

**1.7-SpecialDoor**

**1.7- Special Door:** This parameter can be displayed only if the type of door was set as “special door”. By this parameter, all doors at stops can be adjusted as “Semi Auto” or “Full Auto” or “Full Auto-Open” for per floors individually.

**1.8-DoorPreOpening  
No**

**1.8- Door Pre-Opening:** This parameter was designed to reduce the total travel time in buildings like business centers, hotels, and hospitals etc. where the lift is heavily used. When the lift arrived at the door opening zone towards the target stop with a speed less than 0.3m/sec, the specially designed ESP card enable door contact and lock circuits to be shunted and “open” command is given to the door. When the door starts to open, the lift is stil in motion. Thus, as the waiting time for the door to be opened is reduced, total course time reduces too. For this operation, ESP card designed by special security relays is used. Determination of the door opening zone requires the installment of OSB power switch. Door early opening operation can be used for both roped and hydrolic lifts.

- Yes : In proper conditions door early opening operation is applied.
- No : Door early opening function is not used.

**1.9-RelevelingWithOpe  
No**

**1.9- Releveling With Open Doors:** This parameter can be displayed for only hyraulic lifts. If for any reason the hydrolic lift slips up or down from the floor level, during standing still with its door open, control card senses this state, shunts door contact and lock circuits through ESP card and brings the lift to the exact floor level. This function can not be used without ESP card. (Door closed levelling feature is available as a standard.) It is particularly used in load carrying lifts. For example, in a load carrying lift, while the cabin is loaded using a forklift, the lift may slip downwards a little. In that case, while the door is open, it moves the cabin to the exact floor level.

- Yes : In proper conditions door open levelling operation is done.
- No : Door open levelling function is not used.

**P2-TIMES**

**2.1-BusyTime  
8 seconds**

**2.1-Busy Time:** This parameter determines busy time.

**2.2-WaitTimeAtStops  
4 seconds**

**2.2-Wait Time At Stops:** During collecting, before heading towards the other records, the wait time on the stop is determined by this parameter.

**2.3-LockWaitTime  
10 seconds**

**2.3-Lock Wait Time:** Control card lets the pump released at the end of a pre-determined time to prevent the pump to be harmed by staying pulled for a long time and a fault code is generated. This limit time can be set through this parameter.

**2.4-DoorStayOpenedTi  
6 seconds**

**2.4-Door Stay Opened Time:** In lifts with fully automatic doors, after the lift’s door opened the control card starts to count the time set through this parameter. At the end of this time the door is closed.

**2.4-DoorStayOpenedTi**  
6 seconds

**2.4-Door Stay Opened Time:** In lifts with fully automatic doors, after the lift's door opened the control card starts to count the time set through this parameter. At the end of this time the door is closed.

**2.5-OpenDoorFaultTim**  
20 seconds

**2.5-Open Door Fault Time:** At the end of the time determined by this parameter, if the door of the lift has not yet closed, control panel comes to the out of service mode. If group operation is present, the records are transferred to the other lift.

**2.6-Parking Time**  
30 seconds

**2.6-Parking Time:** The wait time before heading towards the park stop can be set through this parameter.

**2.7-SlowTravelTime**  
10 seconds

**2.7-Slow Travel Time:** This parameter is used to prevent slow winding of lift motor staying energized for a long time and being damaged. To prevent burning of the winding, motor is not allowed to be started for more than determined time.

**2.8-FastTravelTime**  
15 seconds

**2.8-Fast Travel Time:** The maximum allowed time between two neighbor stops are determined by this parameter. For example, if a lift accidentally turned into the brake mode, as it will not be able to reach to the new stop, it can stop safely.

**2.30-DriftingTime**  
0.0 seconds

**2.30-Drifting Time:** this parameter can only be displayed for the roped VVVF type lifts. In speed controlled control panels, to obtain more sensitive stopping, at the end of the second speed after this determined time a third speed command is given to the lift.

**2.31-Rx Delay**  
1.0 seconds

**2.31-RX Delay:** This parameter can only be displayed for the roped VVVF type lifts. In speed controlled control panels, the main contactors are desired to be released with a delay. This delay is set through this parameter.

**2.60-StarDeltaTime**  
0.8 seconds

**2.60-Star Delta Time:** This parameter can only be displayed for the lift types set as star-delta hydrolic. The operation time of the motor during star connected starting can be set through this parameter.

**2.61-ValveDelayAtRun**  
0.5 seconds

**2.61-Valve Delay At Running:** This parameter can only be displayed for hydrolic lifts with star-delta or soft start. To obtain a comfortable start-up, which depends also on the brand of the hydrolic unit, after the motor starts to operate in delta connected mode, the valve opening delay time having a value advised by the manufacturer can be set through this parameter.

2.62-MotorDelayAtStop  
0.4 seconds

**2.62-Motor Delay At Stopping:** This parameter can only be displayed for hydrolic lifts with star-delta or soft start. To obtain a comfortable stopping, which depends also on the brand of the hydrolic unit, after the exact floor level (JF) information comes, the stop delay of the motor having a value advised by the manufacturer can be set through this parameter.

2.63-SoftStartContDelay  
2.0 seconds

**2.63-Soft Start Contactor Delay:** This parameter can only be displayed for hydrolic lifts with soft start. As is well-known, to reduce mechanical stres and vibrations and high inrush current during start-up, the motors are started with soft starters. Most of the soft starters on the market, has soft stop feature besides the soft start feature. To be able to use this function of the starters, the contactor at the output of the starter can be delayed for a period of time set through this parameter. Stopping time can be set on the soft starter.

2.64-ValveDelayAtStop  
2.0 seconds

**2.64-Valve Delay At Stopping:** This parameter can only be displayed for hydrolic lifts with star-delta or soft start. To obtain a comfortable stopping, which depends also on the brand of the hydrolic unit, after the exact floor level (JF) information comes, the delay time to shut off the valves can be set through this parameter.

### P3-STOP SETTINGS

3.1-NumberOfStops  
16

**3.1-Number of stops:** This parameter determines the number of stops on the lift. Thus, assigning a record for a larger number than the determined stop number is prevented during the installment and maintenance. Number of stops has to be set for particularly the lifts which use “counter” as floor selector. Gizmo control card can operate for up to 16 stops without requiring any expansion call card, in which control type is set as simple control or complex control. For the lifts, in which the control type was set as one button down direction one button up direction or one button bidirection, it can operate for up to 8 stops without expansion call card and 16 stops with expansion call card. For the lifts, in which control type was set as double button full collective, it can operate for up to 6 stops without expansion call card and 11 stops with expansion call card. In case control type was set as two buttons bidirection, the maximum number of stops can be set as 11. The wiring diagram of the calls can be seen in the drawings numbered 6x.

### 3.2-DisplayOutputType 7 Segments Display

**3.2-Display Output Type:** Gizmo control card can give the outputs of gray, inverted gray, binary, inverted binary outputs, as well as classical 7 segments from display outputs. Hence, the system operation is possible without needing any converter card for different buttons.

- 7 Segments Display : Classically used parallel wired connection system.
- Gray Code : From a,b,c,d outputs, M0,M1,M2 and M3 gray code outputs respectively can be used.
- Inverted Gray : The inverse of gray code can be obtained from a,b,c,d outputs.
- Binary Code : From a,b,c,d outputs, B0,B1,B2 and B3 binary code outputs can be used.
- Inverted Binary : The inverted binary code can be obtained from a,b,c,d outputs.

### 3.3-Ser.Comm.Display 7 Segments Display

**3.2-Serial Comm. Card Display Output Type:** Kartopu Over-Cabin Serial Communication Card can give the outputs of gray, inverted gray, binary, inverted binary outputs, as well as classical 7 segments from display outputs. Hence, the system operation is possible without needing any converter card for different buttons.

- 7 Segments Display : Classically used parallel wired connection system.
- Gray Code : From a,b,c,d outputs, M0,M1,M2 and M3 gray code outputs respectively can be used.
- Inverted Gray : The inverse of gray code can be obtained from a,b,c,d outputs.
- Binary Code : From a,b,c,d outputs, B0,B1,B2 and B3 binary code outputs can be used.
- Inverted Binary : The inverted binary code can be obtained from a,b,c,d outputs.

### 3.4- DisplaySettings

**3.4-Display Setting:** This parameter can only be displayed if display output type parameter was set as a,b,c,d, segment. For each stop, display settings can be set through this parameter. When the menu is entered to adjust parameters, the bottom line of the screen displays "Stop:" Disp:0". To change the stop number, while it blinks up-down buttons are used to reach the desired stop. Then, Enter button is pressed to make the display value blink. Up-down buttons again used to make desired digital adjustment. To make adjustment for another stop, Esc button is pressed and stop number is made blinking. If while the stop number is blinking, the Esc button is pressed, the changes that have been made is cancelled and menu is exited. Similarly, while the display number is blinking, Enter button is pressed the changes are saved and menu is exited.

### 3.4- Fire Stop Cancel

**3.4-Fire Stop:** If this function is activated, when the fire contact is closed and 24V is applied to the connector numbered 816, the lift automatically directed to the lift stop determined by this parameter. If during the movement of the lift, the fire stop is on the movement direction, all calls are erased and the lift instantly directed to the fire stop. If the lift is moving on the opposite direction, it stops on the first stop. All calls are erasen. It moves towards the lift stop without opening the door.

On the lift stop the lift waits with its doors open and calls are not responded. In that situation, the lift can only move by driver or inspection buttons. When 24V power is cut from the connector numbered 816, the lift turns back to its normal operating mode. If you do not want to use this feature, set this parameter as “cancel”.

3.5-ParkingStop  
Cancel

**3.5-Parking Stop:** If the lift stays in standstill during the time set through lift park time parameter, the lift gets record to the stop set through this parameter and moves to this stop by itself. If you do not intend to use this feature, set this parameter as “cancel”.

## P4-SHAFT INFO

4.1-SensorType  
GrayCode

**4.1-Sensor Type:** As well as operating with four bistables classically ordered in gray code, Gizmo control card can also operate with one bistable ordered in counter type. By this parameter, you have to inform the control card about the used system. In hydrolic lifts or halatlı lifts with door pre-opening feature, counter type magnet ordering is used as a standart. For this reason, this parameter is not displayed in these systems. **WARNING !:** In the lifts using counter type magnet order, make sure that 817 lower limit breakerswitch, and 818 higher limit breaker switch operates correctly.

- Gray code : Classical gray coded magnet ordered operating system.
- Counter : Counter type magnet ordered operating system.

4.2-PositionReset  
No

**4.2-Position Reset:** In systems operating in counter type, even in case of grid-line power interrupt, the latest stop lift stands are kept in memory. But ins some special circumstances, when power is recovered, a position reset may be desired. For example, in lifts with battery powered rescue systems, position reset may be done by activating this parameter. In systems using gray code, this menu is not displayed as position reset is not needed.

- No : Do not apply position reset operation.
- Yes : Apply position reset operation.

4.3-NeighborStopsNum  
15

**4.3-Neighbor Stops Number:** Gizmo control system can set two different slowing down points for neighbor and distant calls for the lifts with speeds more than 1,0m/sec. For neighbor calls, the speed of the lift must be set to approximately 1m/sec and for neighbor calls the lift starts to slow down 1 magnet prior, in regard to the information coming from M1 magnet. For distant calls, it starts to slow down on the magnet set through “4.4 Slowdown distance”. Therefore, the point to start slowing down can be determined by the following manner.

A=[Target stop]-[The stop cabin is parked]

If A is lower or equal to the neighbor stop number, the lift moves with a speed of 1,0m/sec and it starts to slow down one magnet prior, in regard to the information coming from M1 magnet. If number of neighbor stops is larger than A, the lift starts to slow down prior to a determined value, which is set through the “4.4-Slowdown distance” parameter, in regard to the information coming from M0 magnet.

NOTE: In speed controlled panel systems, in which the speed is less than 1m/sec and in classical double speed systems, there is no need to place M0 magnet. Placing only M1 magnet is enough. However, “4.3-Number of Neighbor Stops” parameter has to be set as “CANCEL”.

## P5-OTHER SETTINGS

5.1-Auto.ResetKrc  
No

**5.1-Automatic Reset KRC:** For the conformity to EN81-1/2 directives, the positions of the contactors used in control panel are controlled by Gizmo. However, for the countries in which Europe standards are not applied, KRC has automatic reset function. This function can be set through this parameter. **WARNING !** : For the conformity to EN81-1/2 directives, it HAS TO be set as “no”.

- Yes : Automatic reset function is on.
- No : Automatic reset function is off.

5.2-Auto.ResetMaxLowS  
No

**5.2-Auto Reset Max. Low Speed Time Fault:** For the conformity to EN81-1/2 directives, after the maximum low speed fault occurred, the lift must be blocked. For the countries in which Europe standards are not applied, low speed movement time fault has automatic reset function. It can be set through this parameter. **WARNING !** : For the conformity to EN81-1/2 directives, it HAS TO be set as “no”.

- Yes : Automatic reset function is on.
- No : Automatic reset function is off.

5.3-Auto.ResetMaxHighS  
No

**5.3-Auto Reset Max. High Speed Time Fault:** For the conformity to EN81-1/2 directives, after the maximum high speed fault occurred, the lift must be blocked. For the countries in which Europe standards are not applied, high speed movement time fault has automatic reset function. It can be set through this parameter. **WARNING !** : For the conformity to EN81-1/2 directives, it HAS TO be set as “no”.

- Yes : Automatic reset function is on.
- No : Automatic reset function is off.

5.4-Rx Relay  
Cancel

**5.4-Rx Relay:** Some relays placed on Gizmo can be programmed for various aims. Rx relay can be used to get inspection, gong, error, lift functions and lift information. However, if the lift type was set as roped vvvf, Rx relay functions as classical Rx relay, if the lift type was set as hydrolic lift, it functions as delta relay. Therefore, this menu can be displayed only if the lift type was set as roped.

- Cancel : Function can be cancelled.
- Inspection : When the lift is taken to inspection this relay is turned on.
- Gong : When the target stop was reached, this relay switches on for one second and then it switches off.
- Error : If an error occurs, this relay switches on. When the lift starts to run, it switches off.
- Lift functions. : When the lift starts to run this relay switches on. It switches off when the movement ends.
- Lir : This relay can be operated as pump relay.

**5.5-Rlir Relay  
Cancel**

**5.5-Rlir Relay:** Rlir relay can be used to get information about inspection, gong, error, lift functions and lir. However, Rlir relay can only be displayed if the type of the automatic door was set different from semi-automatic door. If it was set as semi-automatic, this relay is standarty lir relay. The settings of Rx relay can also be applied to this relay.

**5.6-Rsvr Relay  
Cancel**

**5.6-Rsvr Relay:** Rsvr relay can be used to get information about inspection, gong, error, lift functions and lir. However, Rsvr relay can only be displayed, if the type of the lift was set as roped lift or roped vvvf lift. In case the type of the lift was set as hyraulic lift, this relay standarty functions as star relay. The settings of Rx relay can also be applied to this relay.

**5.7-Rrvd Relay  
Cancel**

**5.7-Rrvd Relay:** Rrvd relay can be used to get information about inspection, gong, error and lift functions. However, Rrvd relay can only be displayed, if the type of the lift was set as roped lift or roped vvvf lift. In case the type of the lift was set as hyraulic lift, this relay standarty functions as rescue relay.

- Cancel : Function is cancelled.
- Inspection : This relay is switched on when the lift is taken to inspection.
- Gong : When the target stop is reached, this relay is switched on for one second and then it switches off.
- Error : This relay switches on when an error occurs. The relay switches off, when the lift starts to run again.
- Lift functions : This relay switches on when the lift starts to run. The relay switches off when motion ends.

**WARNING ! :** Do not use this relay to switch high current inputs directly. You can use this relay to switch another relay.

**5.11-StopClearCall  
Yes**

**5.11-Stop Clear Call:** When the “Stop” (120) info is not given, you can decide to clear or not to clear existing calls by this parameter.

## P6-OTHER FEATURES

**Press UP-DOWN  
c01→InspectCabin**

**Press UP-DOWN  
c02→InspectWell**

**Inspection:** GIZMO control card senses the lift is in inspection from two terminal points namely 867 and 869. 867 come from inspection paco switch in the panel, while 869 comes from inspection paco switch in the well. If 24V is not present in any of these connectors, that means the lift is in inspection. The priority is always on the well. The screen shows whether the lift is taken to inspection from the panel or from the well. When the lift is taken to inspection (i.e. 24V power is cut in connector 869 or 867) maintenance operation takes place. In that case, if the lift is moving it halts and all available calls are erasen, out of service lamp turnes on. Using inspection down (500) and inspection up (501) buttons, the lift can be moved upwards and downwards in low speed. The movement of the lift in inspection is limited by lower limit stopper bistable switch in the lowest floor and upper limit stopper bistable switch in the highest floor. When connectors numbered 867 and 869 are supplied with 24V, the lift returns to its normal operation.

**Over Load:** If the cabin weights more than allowed, the over load contact in cabin is turned on and 24V is supplied to the connector numbered 804. Microcontroller does not let the lift to move. In that case, LCD screen displays “H5.OverLoad” warning. Cabin lamp is left turned on and if the automatic door type is chosen fully automatic, it is ensured to be stayed open. When the over load contact is turned on, the movement is re-allowed. During movement, over load control is not implemented.

**Full Load:** If the cabin weight is in full capacity, full load contact is turned on and thus 24V is supplied to connector numbered 805. In that case, the microcontroller ensures that the lift does not stop for the outer calls, as no space is available for new passengers, but call information is preserved.

**Watman :** If the watman switch is turned ON and thus 24 Volt is supplied to the connector numbered 812, all calls are erasen and from now on only cabin calls are accepted. System returns to normal mode when the watman switch is turned off.

**Contactor control(KRC):** 24V signal, which is serially connected through normally closed contacts of contactor providing movement, is connected to Gizmo control card’s KRC connector. Therefore, the card checks that contactors operate well when the lift stopped or moved. In case a fault occurs, system halts instantly.

## P7-FAULTS CODES

GIZMO lift control system detects a large number of faults, shows them on the screen and assists the user solving the problem easily. The fault codes shown in screen are explained here.

F1.StopFault  
c02→t-- 100=25V

**F1.Stop Fault:** Stopping circuit does not conduct. When this fault occurs the lift is instantly halted and all calls are erasen. The lift returns to its normal operation when stop circuit is short circuited.

F2.DoorCantClose  
c02→t-- 100=25V

**F2.Door Can’t Close:** If the door is left open for a period of time longer than determined by “P2.5-Open door fault time” parameter, control card erases all records, gives this fault and out of service lamp signals. The lift returns to its normal operation when the door is closed.

F3.PTC Fault  
c02→t-- 100=25V

**F3.PTC Fault:** Motor’s temperature is continuously monitored by a temperature sensor attached to the coils of the lift’s motor. If the temperature limit value is exceeded while the lift is moving, the control system halts at the nearest stop in moving direction and existing records are cancelled. New records are not accepted until the temperature decreases below the limit value.

F4.KRC Fault  
c02→t-- 100=25V

**F4.KRC Fault:** A signal terminal connected through normally closed contacts of contactors is connected to KRC. Therefore, in case of any fault such as sticking of contactor terminals, this fault occurs in control card and new record is not accepted. If automatic reset KRC parameter was set as “Yes”, after the KRC fault when the KRC signal returns to normal the fault is reset and lift starts to service. If the parameter was set as “No”, the lift is shot down until repair person fixes the problem and reset the system.

**F5.Overload**  
c02→t-- 100=25V

**F5.Over Load:** If the weight of the cabin is more than allowed, over load contact is turned on and 24V reaches to the connector numbered 804. Control card does not let the lift to move.

**F6.No818LimitSwitch**  
c02→t-- 100=25V

**F6.No 818 Limit Switch:** When higher limit stopper bistable switch informs that the lift is on the highest floor, running of the lift upward is not allowed. If the lift is not on the highest floor, check the higher limit stopper switch and connections.

**F7.No817LimitSwitch**  
c02→t-- 100=25V

**F7.No 817 Limit Switch:** When lower limit stopper bistable switch informs that the lift is on the lowest floor, the running of the lift downward is not allowed. If the lift is not on the lowest floor, check the lower limit stopper switch and connections.

**F8.MaxLowSpeedTime**  
c02→t-- 100=25V

**F8.Max. Low Speed Time:** It determines the maximum allowed time for the lift to move in low speed. If the lift can not reach to the new stop in this time the lift instantly stops. If automatic reset parameter of low speed fault was set as “Yes”, fault is reset and lift starts to service. If this parameter was set as “No”, the lift can not service until repair person fixes the problem and reset the system

**F9.MaxHighSpeedTime**  
c02→t-- 100=25V

**F9.Max. High Speed Time:** It determines the maximum allowed time for the lift to move from one floor to the other at high speed. If the lift can not reach to the new stop in this time the lift instantly stops. If automatic reset parameter of high speed fault was set as “Yes”, fault is reset and lift starts to service. If this parameter was set as “No”, the lift can not service until repair person fixes the problem and reset the system.

**F10.M0 Fault**  
c02→t-- 100=25V

**F10.M0 Fault:**

**F11.M1 Fault:**

**F11.M1waitedJFchange:**

**F12.M2 Fault:**

**F13.M3 Fault:** This fault occurs in case the sensed floor selection information is different than then expected, during the travel of the lift in high speed. The lift instantly stops and calls are erasen.

**F14.JFwaitedM0change**  
c02→t-- 100=25V

**F14.JF waited M0 change:**

**F15.JF waited M1 change:**

**F16.JF waited M2 change:**

**F17.JF waited M3 change:** In double speed lifts, while travelling in low speed, the stopping of the lift at the precise floor level is accomplished by cutting 24V power from bistable power switch numbered 142. During travelling of the lift in low speed, if different magnetic information comes while waiting the information from JF to stop, “JF fault” occurs. The lift is stopped and calls are

**F18.OSB Fault**

c02→t-- 100=25V

**F18.OSB Fault:** In roped lifts with door pre-opening feature, AND in hydrolic lifts with door pre-opening and door open levelling feature, OSB magnet and OSB arm must be installed. As soon as the lift gets out of the lock opening zone, OSB information must be terminated. If it reaches to the new stop without terminating the OSB information, this fault is signalled and system does not accomplish door pre-opening and door open levelling functions for safety reasons.

**F19.LevellingTravelTime**

c02→t-- 100=25V

**F19.Levelling Travel Time Fault:** A time duration of 10 seconds has been determined for system to be levelled. If in this duration, the levelling operation has not been completed, system signals error and cancels the levelling process.

**F20.LockFault**

c02→t-- 100=25V

**F20. Lock Fault:** Gizmo control card lets the Rlir pump relay turned on and wait the lock to be energized for a duration determined by “P2.3-LockWaitTime. If the lock do not get energized at the end of this time, Rlir relay switches off for a second and it switches on again. It tries three times for the lock to get energized. If it still does not get energized, it signals this fault, erases all calls and turns to the standby mode.

## **8. FREQUENTLY ASKED QUESTIONS (FAQ)**

- *No movement during inspection.*

When the system was taken to inspection using inspection power switch placed on the panel, signal numbered 867, when it was taken to inspection using inspection power switch in well, signal numbered 869 must turn off. Control card displays whether the lift was taken to inspection from the well or from the panel. Inspection movement buttons turn on signals numbered 500 and 501. If they are not turned on, cabin connections must be checked. When the lift has been taken to inspection, safety circuit is cut off. Safety circuit closes its loop through inspection movement buttons. When the buttons are pressed, check that safety circuit closes its loop.

Limit switches should not prevent the movement. Thereby, 817 (KSR1) and 818 (KSR2) cutting signals in the card must be on. Else, limit power switches must be checked.

Make sure that 120 (Stop), 130 (Door contact), 140 (Lock) circuits conduct. (All signals on the control card must be on).

- *The lift stops without decelerating.*

If the same problem is present in every stop, probably precision stop magnetic switch is damaged. When the lift starts decelerating, signal 142 in the card must be on. If the problem exists in only one stop, the magnets and the distance between magnets and magnetic switches must be checked.

- *The lift hits above.*

Check that upper limit switch 818 (KSR2) circuit functions well. In last stop's deceleration level 818 signal in the card must be off. Else, tubes and magnets must be checked.

Floor stopping magnetic 142 may be stucked. Signal 142 must be off in precise floor levels. If not, check the magnetic switches and magnets.

- *The lift hits below.*

Check that lower limit switch 817 (KSR1) circuit functions well. In the last stop's deceleration level, 817 signal in the card must be off. Else, tubes and magnets must be checked.

Floor stopping magnetic 142 may be stucked. Signal 142 must be off in precise floor levels. Else, check the magnetic switches and magnets.

- *When one button is pressed in the card, all recorded signals turn on.*

Probably, the common terminal of signal lamps are connected to each other, but 100 (+24V) is not connected to the connector. Thereby, buttons loop through common terminal.

- *Position count gets mixed.*

Check that number of stops and digital settings are adjusted correctly. Make sure that 817 breaker circuit in the first stop and 818 breaker circuit disconnect. By monitoring M1 signal during movement, check if any faulted signal is generated. M1 must be blinking at least once in each stop. If any problem is observed, magnetic switch may be too far from the magnets, it may be damaged or a magnetisation in the rails may have occurred.

- *M1 signal is blinking but the card does not count the stops.*

The stops can only be counted correctly, in case 817,818 limit breakers close their circuits.

Therefore, 817, 818 limit breaker signals are supposed to be on, except for upper and lower limits. Keep in mind that when the lift is moved by switching the contactors, the counting can not be done as the card does not know which direction the lift moves.

## **9. IMPORTANT CONSIDERATIONS IN INSTALLATION OF THE PRODUCT**

Panel manufacturer firm producing GIZMO control card and lift control panel must have sufficient knowledge and experience on EN-81 standard, other norms, regulations and directives dealing with this subject. In case the instructions given here have not been complied, EEM Imp. Exp. Trade Co. does not assume responsibility in appropriateness of the produced panel to the EN-81 standards. Installation of GIZMO control card and double speed lift control panel is shown in schematics. The important considerations throughout the manufacturing of control panel are explained below item by item.

- A minimum space of 9mm must exist between GIZMO control card and control panel surface. GIZMO control card must be fixed on 4 holes in each corner.
- For EMC compliance, control card must be laid away from the contactors.
- 24VDC signal cables and other cables must be placed separately.
- Some conductive particles such as iron powder produced during installation of all electronic cards into the panel must be carefully cleansed. Else, these particles may cause damage by falling over the control card or other equipment during transport or installation.
- Connections between GIZMO control card and connector cards must be implemented as shown in the schematics. To avoid any mistake, connector names are written in large typesize.
- The contactors used for the lifts having AC motor must be AC3 class as described in EN60947 and they must be rated in regards to motor power. The connections must be done as shown in the schematics.
- The auxiliary contacts placed over the contactors must comply with EN60947 standard and it must be assured that contactors open and close at the same time with power contacts.
- It must be assured that damping circuits (series resistor-capacitor) are connected to contactor coil terminals.
- As shown in the schematics, a 20mA leakage current fuse must be used to cut supply voltage of safety contacts in case of a leakage from safety contacts to chassis.
- Bridge diode connections of brake and pump must be done as shown in the schematics and they must be electrically isolated.
- For long and healthy operation, brake coil output contacts and RU1 and RU2 contacts are needed to be power contacts.
- Control panel inspection switch connection must be done as shown in the schematics. By means of this connection, when the inspection switch over the cabin is turned ON, inspection buttons on the control panel can not move the lift.
- Cable contactors, connected to KRC connector that is used to check whether contactors operate well must be serially connected through normally closed contacts. If possible, these normally closed contacts must be auxiliary contacts fixed on contactor, instead of additional auxiliary blocks.
- Following the completion of control panel production, manufacturer must test it by checking all connections.

## **10. IMPORTANT CONSIDERATIONS IN CONNECTION OF CONTROL PANEL TO LIFT SYSTEM AND MAKING THE SYSTEM OPERATIONAL**

The information given here only aims a general description and recommendation. EEM Imp. Exp. Trade Co. in any circumstance does not assume responsibility for any damages and accidents caused by the descriptions given here. The product must only be installed and operated by qualified, trained personnel who have knowledge on EN-81 standard and practices. The operation of the lift must be carried out only after assuring all precautions.

### **10.1- Important Considerations in Connecting Control Panel to Lift System**

- The connections between control panel and motor, cabin and well must be carefully implemented in accordance with the schematics.
- Contactor, automatic fuse, motor protection switch and thermic relay must be rated in accordance with the motor power.
- Neutral and ground cables must be installed separately and panel chassis must be connected to the ground properly.
- The lift must have all the stopping mechanisms mentioned in EN-81 standard and these mechanisms' contacts must be connected to control panel carefully. These connections to safety contacts must be done in accordance with the schematics properly. All safety contacts used must be in compliance with EN60947 standards.

### **10.2- Important Considerations on Preparing the System Become Operational**

- Check that the connections between control panel and lift system are consistent with the schematics.
- Using a measuring device check whether any short-circuit exist between connections.
- Turn ON the inspection switch in control panel.
- Turn ON motor protection switch and power the panel.
- Check that 02-Out of service led in GIZMO control card and out of service leds on floor buttons are operating.
- By checking the leds on control card (which are labelled 5V and 100) make sure that supply voltages exist. Measuring between 100 and 1000 connectors, a voltage should read between 20...26VDC.
- Make sure that all safety contacts are connected in consistence with the schematics and make sure they operate correctly. By checking the leds on control card (120,130,140), make sure that safety contact inputs are active.
- In order to be able to move the cabin in both ways, temporarily connect lower and upper stopper bistable switch inputs with the connector numbered 100. In that case, as the lower and upper stopper bistable switches will not be able to perform their duties, give extreme care during working in the lowest and highest floors.
- As the control panel inspection switch is ON, cabin travels only in low speed. Make sure that low speed coil of the motor is correctly connected, by moving the cabin using up and down buttons placed on control panel. If the pressed button and the travel direction of the cabin do not match, exchange the connection of any two of the U2,V2,W2 terminals on the motor between low speed coil and control panel.
- While the cabin is travelling, measure the voltages between 2001 and 810 connectors and 2000 and 840 connectors. The values should read between 180...240VDC.
- Afterwards, move the cabin in one of the interval floors and turn ON the inspection switch on the cabin. In that case, cabin can not be conveyed using inspection buttons on the control panel.

- Move the cabin to the lowest stop. Place the magnets of gray code, floor stopper and upper and lower limit stopper bistable switches in consistent with the magnets.
- By monitoring stop numbers in LCD screen or in display placed over the control card, check that the ordering has been done correctly.
- Remove the connecting link between lower and upper stopper bistable switch inputs applied through the connector numbered 100.
- Place the cabin in one of the interval floors and turn OFF the over-cabin inspection switch.
- Turn OFF the control panel inspection switch. Therefore, lift returns to its normal operation state and OUT OF SERVICE leds on floor buttons turn off.
- Give a call to the lift and make sure it travels in expected direction in high speed. If the lift does not travel in the expected direction, reverse only two terminals (U1,V1,W1) of motor's connection between high speed coil and control panel.
- In each floor, give calls for both directions and check that the cabin stops in exact floor level. If needed, re-arrange the positions of stopper bistable switch magnets.

! In normal operation state of the lift, it must be assured that lower and upper stopper bistable switch inputs are not linked through the connector numbered 100.

! Check that all safety contacts operate correctly before the lift returns to its normal operating mode.

! Never link safety circuits (120 emergency stopping, 130 door, 140 lock)

## **11. MAINTENANCE AND CLEANING OF GIZMO CONTROL CARD**

- It does not need periodical maintenance.
- If any faulted operation is detected, it must be sent to the manufacturer firm for test and repair.
- It must be kept free of water and any other kind of liquids.
- If needed, the dust over the control card must be cleaned using low pressure air.

## **12. SAFETY NOTICES**

Averting any accident risks in a lift without having user risk (in a lift having security measures such as automatic door complying with standards and over-load system) is in responsibility of subsidiary firms and installation and maintenance firms. Some fundamental security subjects concerned with lift control system are touched on below.

! For the lift system to be fully complied with EN81 standards, control panel of control card and electrical connections must be appropriate. Our firm guarantees that control card is complied to the standards. However, installer firm is responsible for inner and outer connections of control panel and other electrical connections.

! Safety circuit of GIZMO control card operates from 220VAC. Motor start-up contactors are directly supplied from the return terminal of safety circuit. Therefore, in safety circuit, unintentional operations besides control are prevented.

! The terminal numbered 11 in GIZMO control card HAVE TO be connected to the return terminal of safety circuit (140-lock return). Otherwise, risks grow. However, if control

card does not sense the return terminal of safety circuit, it halts the lift instantly. Do not connect safety circuit through any relays or contacts in any way directly or indirectly except for security arrangements.

!Hide the connectors that you attached door contact and lock circuits to the door apertures by avoiding any contact to door chassis. Keep in mind that during the building cleaning water may drain through the cabin. Therefore, it may be necessary to implement safety connections in isolated channels. Otherwise, they must be isolated with isolation bands.

!Door frames must be assured to be connected to the ground bus bar. In case the grounding has not been installed, there is a risk that safety circuit is indirectly linked through door chassis.

!It must be assured that the contactors are not released manually. In that case, safety circuits and control card can not prohibit the lift's movement.

!When the 24 VAC signal fuse is damaged or it permanently remained on, it must be ensured it is not shunted. This may damage GIZMO control card.

!To make sure that cabin lamp stays on when thermic relay in the panel is switched off, supply voltage of cabin lamp (1F) must be directly connected to the electric panel on machine room.

!The safety circuit may lose its functionality by subjecting to wear and tear and exposing to dust, dirt and oil. In periodical maintenances remember to check functions of door contacts and locks.

Consider important that all these precautions are necessary to operate our lifts safely and therefore reduce any accident risk.

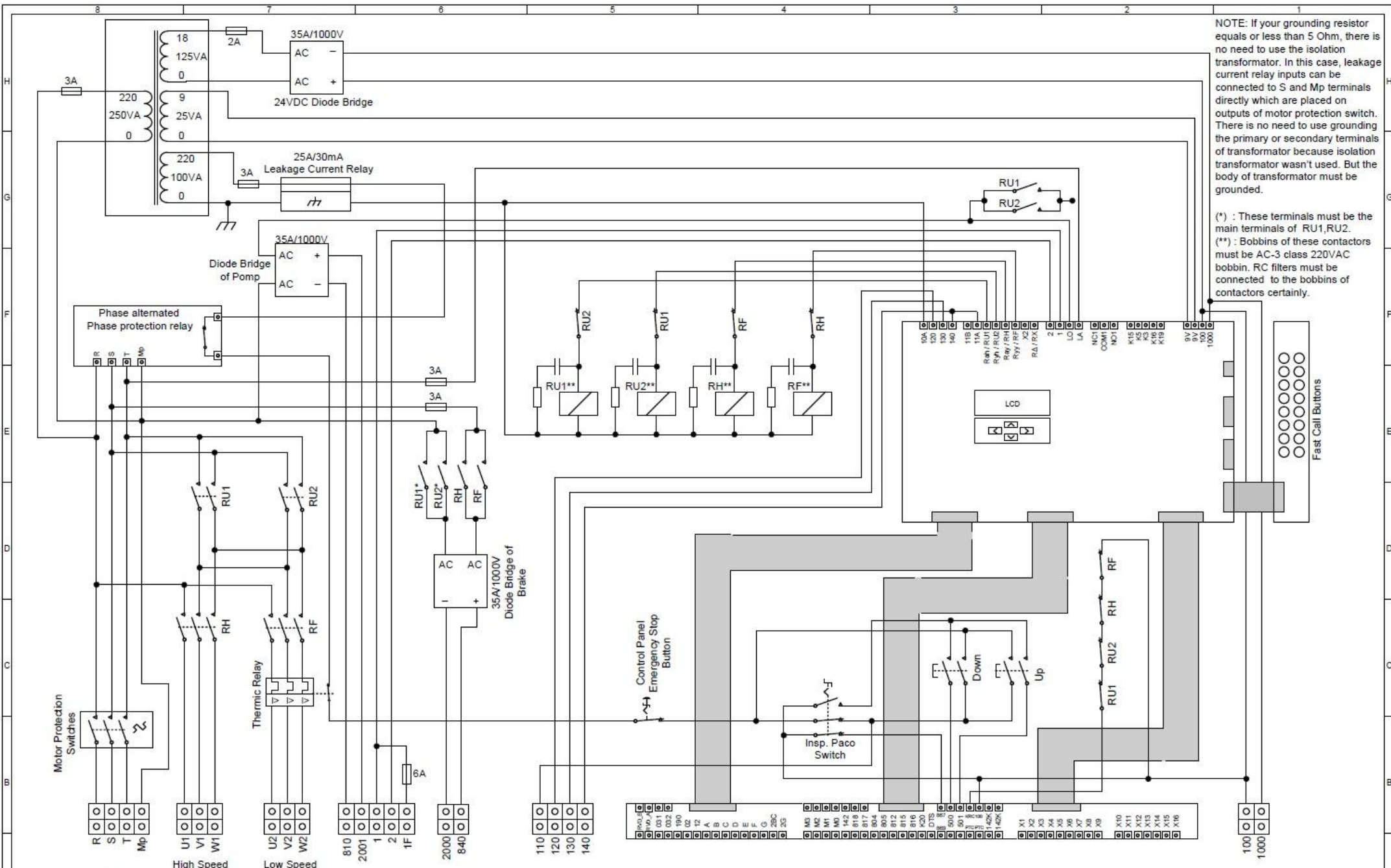

NOTE: If your grounding resistor equals or less than 5 Ohm, there is no need to use the isolation transformer. In this case, leakage current relay inputs can be connected to S and Mp terminals directly which are placed on outputs of motor protection switch. There is no need to use grounding the primary or secondary terminals of transformer because isolation transformer wasn't used. But the body of transformer must be grounded.

(\*) : These terminals must be the main terminals of RU1, RU2.  
 (\*\*) : Bobbins of these contactors must be AC-3 class 220VAC bobbin. RC filters must be connected to the bobbins of contactors certainly.



EEM Imp. Exp. Trade Co.  
Lift Control Systems

Tel : +90.332.342 41 27 - 28  
Fax : +90.332.342 41 29

www.eem.com.tr

Project Name GIZMO Lift Control System  
 Drawing Name Double Speed Control Panel Connection Draw  
 Description

CE  
 Drawer ZD - BA  
 Control SH

Version 3.2 Date 03.09.2008 Draw No: 1A Page 35

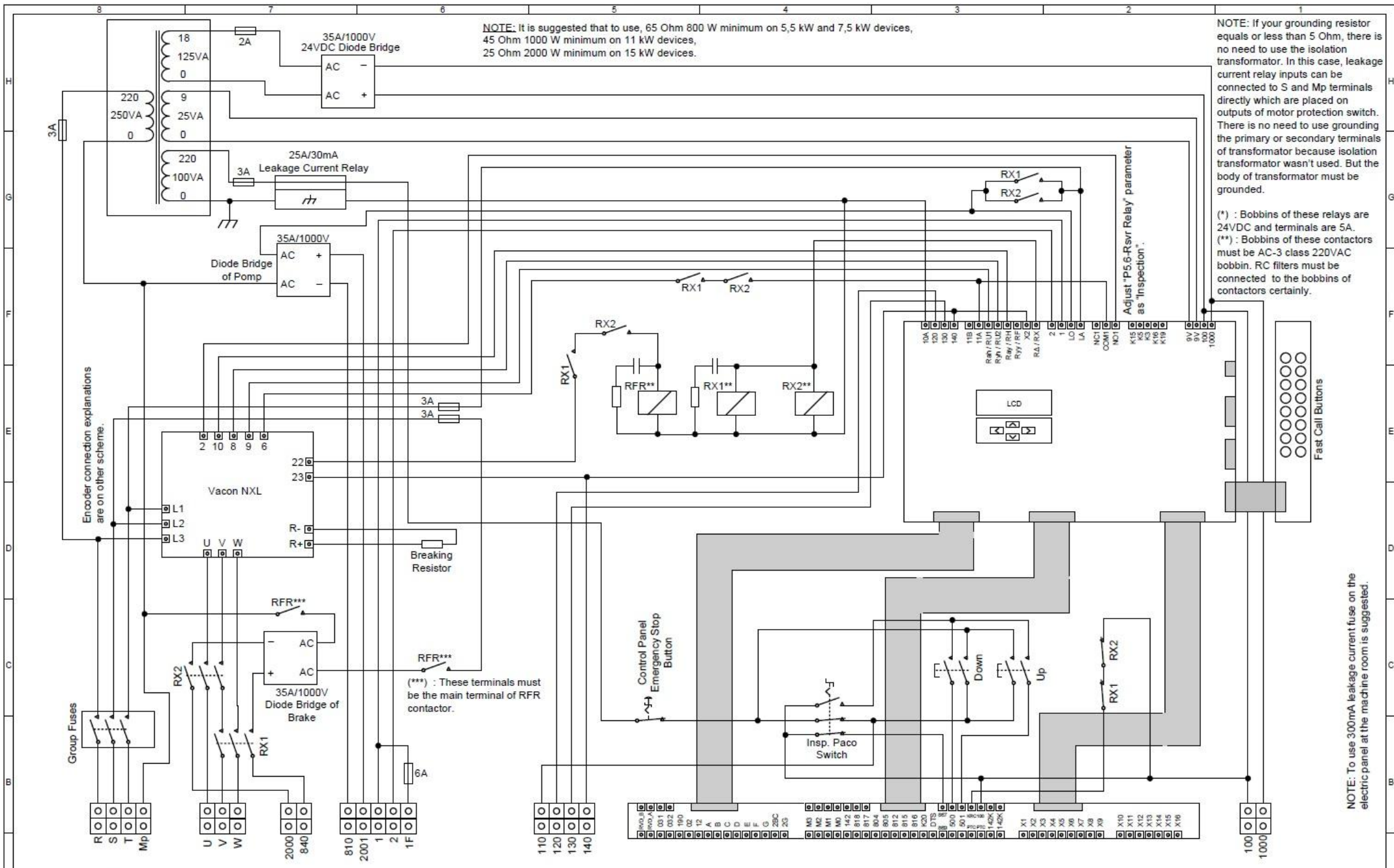

EEM Imp. Exp. Trade Co.  
Lift Control Systems

Tel : +90.332. 342 41 27 - 28  
Fax : +90.332. 342 41 29

www.eem.com.tr

Project Name GIZMO Lift Control System

Drawing Name Vacon NXL Open Loop Speed Controlled Control Panel Connection Draw

Description



Drawer ZD - BA

Control SH

Version 3.2

Date 03.09.2008

Draw No: 2A

Page 36

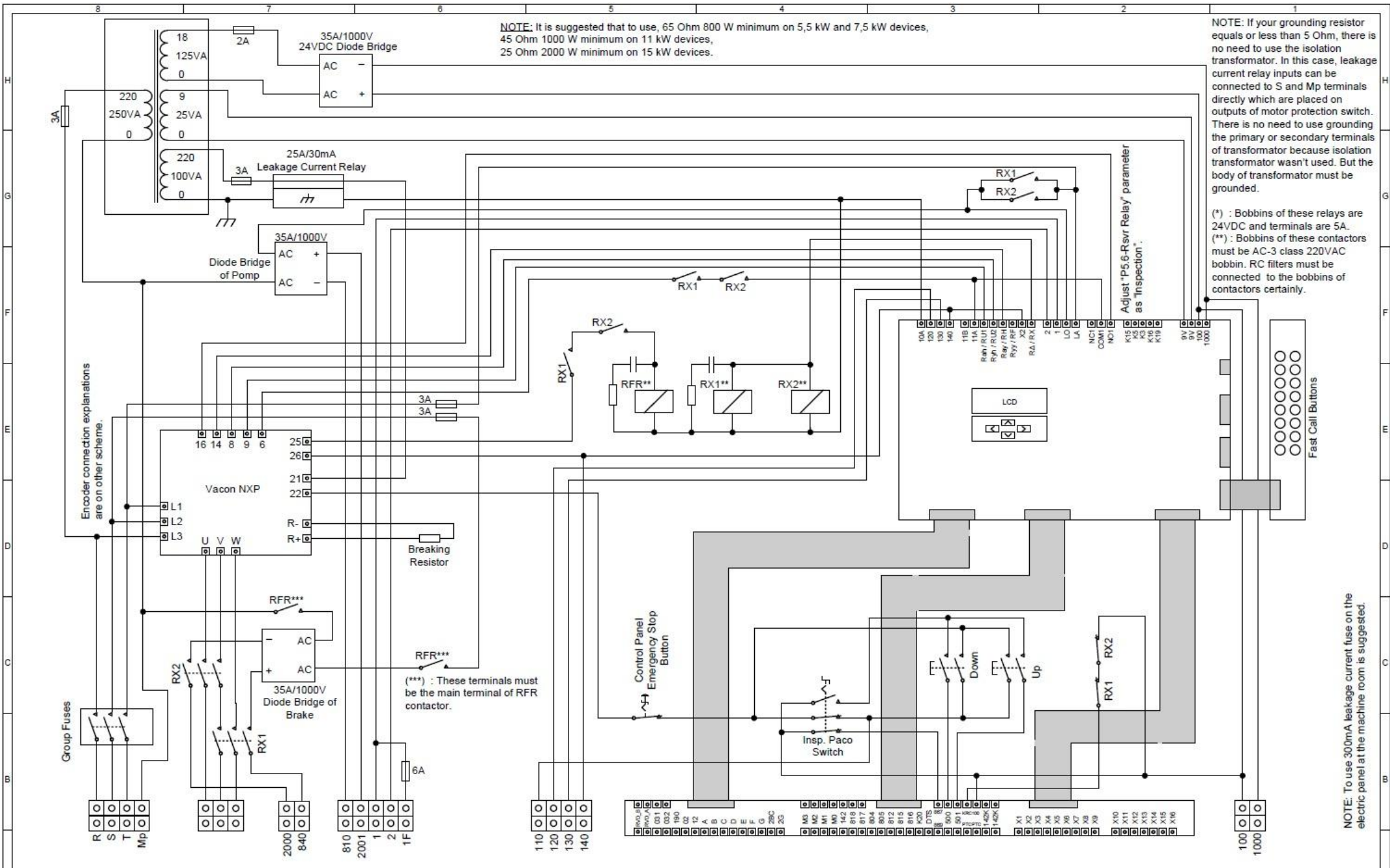

EEM Imp. Exp. Trade Co.  
Lift Control Systems

Tel : +90.332. 342 41 27 - 28  
Fax : +90.332. 342 41 29

www.eem.com.tr

Project Name GIZMO Lift Control System

Drawing Name Vacon NXP Closed Loop Speed Controlled Control Panel Connection Draw

Description

Version 3.2

Date 03.09.2008



Drawer ZD - BA

Control SH

Draw No: 2B

Page 37

On the lifts which are higher than 1,0 m/s speed, connections must be connected as shown in drawing among other 2A and 2B numbered drawings.

So, commands are given by,  
 RU1 relay as **down movement**,  
 RU2 relay as **up movement**,  
 RF relay as **low speed**,  
 RH relay as **middle speed**,  
 Rrvd relay as **high speed**, to the AC speed control device.

Suggested declaration zones is shown below.  
 1,7 meters for 1,2 m/s speed lifts  
 2,0 meters for 1,4 m/s speed lifts  
 2,2 meters for 1,6 m/s speed lifts  
 2,6 meters for 1,8 m/s speed lifts  
 2,8 meters for 2,0 m/s speed lifts

This is a terminal of "High Speed" command for speed control device. ←

This terminal must be connected to,  
 15 numbered terminal for Vacon NXP devices,  
 5 numbered terminal for Vacon NXL devices.

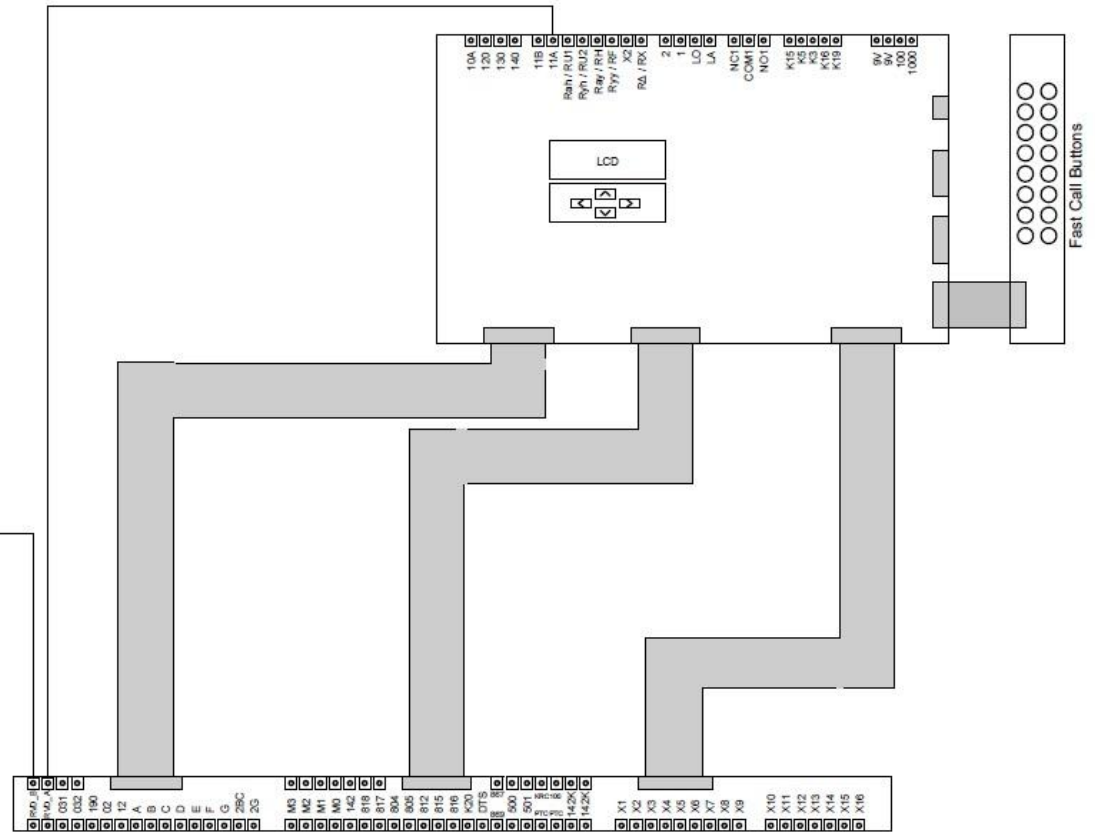

EEM Imp. Exp. Trade Co.  
 Lift Control Systems

Tel : +90.332. 342 41 27 – 28  
 Fax : +90.332. 342 41 29

www.eem.com.tr

Project Name GİZMO Lift Control System

Drawing Name Added Connections of Panel For Higher Speed Lifts Than 1,0 m/s.

Description



Drawer ZD - BA

Control SH

Version 3.2

Date 03.09.2008

Draw No: 2C

Page 38



Brand : AUTONICS  
 Power Source : 12 – 24 VDC  
 Number of Pulses : 1024 pals

CODE : E50S8 – 1024 – 3 – T – 24

Cable	Color	Vacon Connections
A+	Black	1
B+	White	3
Power Source(-)	Blue	9
Power Source(+)	Brown	10
Grounding	Naked	Ground connection

NOTE: Connect 2 and 4 numbered terminals to 9 numbered terminal on Vacon Speed Control Device to complete the connection.



Brand : NIDEC NEMICRON  
 Power Source : 4,5 – 5,5 VDC  
 Number of Pulses : 1024 pals

CODE : NOC – S – 1024 – 2MD

Cable	Color	Vacon Connections
A+	Green	1
A-	Blue	2
B+	White	3
B-	Gray	4
Power Source(-)	Black	9
Power Source(+)	Red	10
Grounding	Naked	Ground connection



Brand : METRONICS  
 MECAPION  
 Power Source : 12 – 24 VDC  
 Number of Pulses : 1024 pals

CODE : S48 – 8 – 1024 – VL

Cable	Color	Vacon Connections
A+	Green	1
A-	Blue	2
B+	White	3
B-	Pink	4
Power Source(-)	Black	9
Power Source(+)	Red	10
Grounding	Naked	Ground connection



Brand : LIKA  
 Power Source : 5 – 30 VDC  
 Number of Pulses : 1024 pals

CODE : I58S – Y – 1024 – Z

Cable	Color	Vacon Connections
A+	Yellow	1
A-	Blue	2
B+	Green	3
B-	Orange	4
Power Source(-)	Black	9
Power Source(+)	Red	10
Grounding	Naked	Ground connection



Brand : WACHENDORFF  
 Power Source : 4,75 – 5,5 VDC  
 Number of Pulses : 1024 pals

CODE : WDG 58B – 1024 – AB – IO5 – S3 – C30

Cable	Color	Vacon Connections
A+	Green	1
A-	Gray	2
B+	Yellow	3
B-	Blue	4
Power Source(-)	White	9
Power Source(+)	Brown	10
Grounding	Naked	Ground connection



Brand : WACHENDORFF  
 Power Source : 10 – 30 VDC  
 Number of Pulses : 1024 pals

CODE : WDG 100H – 38 – 1024 – ABN – I24 – K3 – 050

Cable	Color	Vacon Connections
A+	Green	1
A-	Red	2
B+	Yellow	3
B-	Black	4
Power Source(-)	White	9
Power Source(+)	Brown	10
Grounding	Naked	Ground connection

NOTE: If there is no A– and B– terminals on your encoder, connect 2 and 4 numbered terminals to 9 numbered terminal on Vacon Speed Control Device to complete the connection.



EEM Imp. Exp. Trade Co.  
 Lift Control Systems

Tel : +90.332.342 41 27 – 28  
 Fax : +90.332.342 41 29

www.eem.com.tr

Project Name GIZMO Lift Control System

Drawing Name Frequently used encoders and wire colors.

Description



Drawer ZD - BA  
 Control SH

Version 3.2

Date 03.09.2008

Draw No: 2F

Page 39

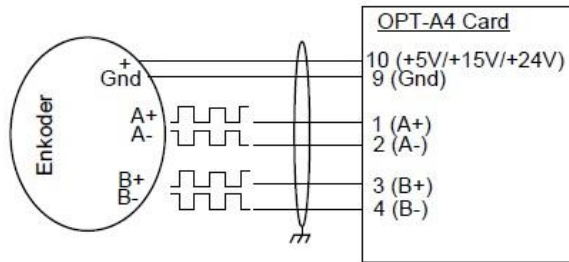

Connection drawing for Differential input, line driver encoder.

- 1 ---- A+
- 2 ---- A-
- 3 ---- B+
- 4 ---- B-
- 9 ---- GND
- 10 ---- +5V/+15V/+24V

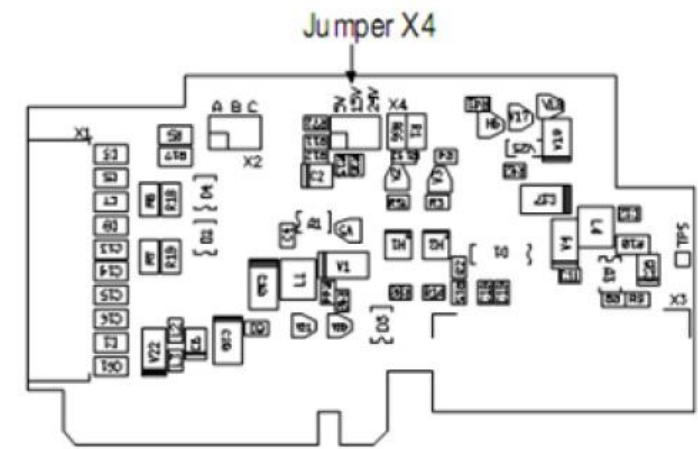
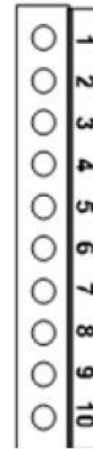

X4 Jumper setting:

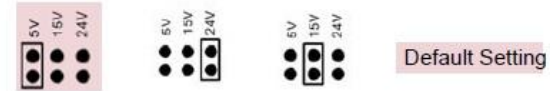

■ How can i understand that which encoder card is mounted to my speed control device?  
 ● You can learn your mounted encoder card name (OPTA4 or OPTA5) by P7.3 parameter. If you see different name in this parameter, a different card may be integrated. If this parameter doesn't run, it means that, there is no integrated card on your device.

### MEANINGS OF COLORS IN DIFFERENT LANGUAGES

TURKISH	ENGLISH	GERMAN	ITALIAN	SPANISH	FRENCH
SİYAH	BLACK	SCHWARZ	NERO	NEGRO	NOIR
BEYAZ	WHITE	WEISS	BIANCO	BLANCO	BLANC
KIRMIZI	RED	ROT	ROSSO	ROJO	ROUGE
SARI	YELLOW	GELB	GIALLO	AMARILLO	JAUNE
MAVİ	BLUE	BLAU	BLU	AZUL	BLEU
YEŞİL	GREEN	GRÜN	VERDE	VERDE	VERT
KAHVERENGİ	BROWN	BRAUN	MARRONE	MARRON	BRUN
MOR	VIOLET	VIOLETT	VIOLA	VIOLETA	VIOLET
PEMBE	PINK	ROSA	ROSA	ROSA	ROSE
GRİ	GRAY	GRAU	GRIGIO	GRIS	GRIS
TURUNCU	ORANGE	ORANGE	ARANCIONE	NARANJA	ORANGE
ŞEFFAF	TRANSPARENT	DURCHSICHTIG	TRANSPARENTE	TRANSPARENTE	TRANSPARENT
BEJ	BEIGE	BEIGE	BEIGE	BEIGE	BEIGE



EEM Imp. Exp. Trade Co.  
Lift Control Systems

Tel : +90.332. 342 41 27 - 28  
Fax : +90.332. 342 41 29

www.eem.com.tr

Project Name GİZMO Lift Control System

Drawing Name Vacon NXP Closed Loop Speed Control Device Encoder connection drawing with OPTA4 Encoder Card

Description

Version 3.2

Date 03.09.2008



Drawer ZD - BA  
Control SH

Draw No: 2D Page 40

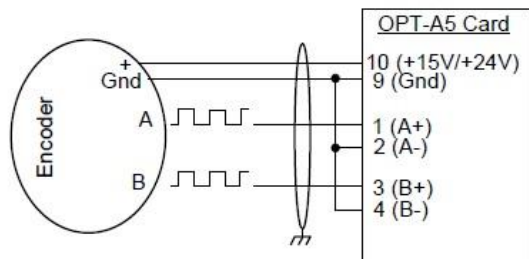

Open source, single ended encoder connection drawing.

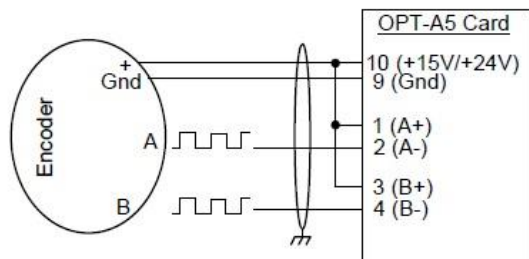

Open collector, single ended encoder connection drawing.

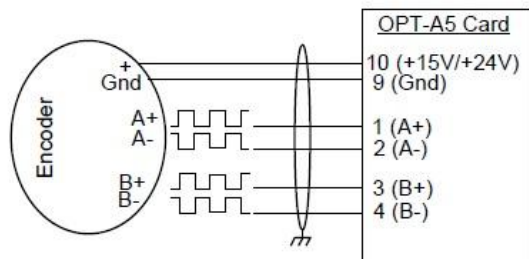

Differential input, line driver encoder connection drawing.

OPT-A5

- 1 ----- A+
- 2 ----- A-
- 3 ----- B+
- 4 ----- B-
- 9 ----- GND
- 10 ----- +15V/+24V

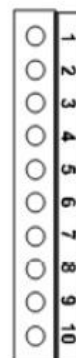

X4 Jumper setting:



Default Setting

- How can i understand that which encoder card is mounted to my speed control device?
- You can learn your mounted encoder card name (OPTA4 or OPTA5) by P7.3 parameter. If you see different name in this parameter, a different card may be integrated. If this parameter doesn't run, it means that, there is no integrated card on your device.

### MEANINGS OF COLORS IN DIFFERENT LANGUAGES

TURKISH	ENGLISH	GERMAN	ITALIAN	SPANISH	FRENCH
SİYAH	BLACK	SCHWARZ	NERO	NEGRO	NOIR
BEYAZ	WHITE	WEISS	BIANCO	BLANCO	BLANC
KIRMIZI	RED	ROT	ROSSO	ROJO	ROUGE
SARI	YELLOW	GELB	GIALLO	AMARILLO	JAUNE
MAVİ	BLUE	BLAU	BLU	AZUL	BLEU
YEŞİL	GREEN	GRÜN	VERDE	VERDE	VERT
KAHVERENGİ	BROWN	BRAUN	MARRONE	MARRON	BRUN
MOR	VIOLET	VIOLETT	VIOLA	VIOLETA	VIOLET
PEMBE	PINK	ROSA	ROSA	ROSA	ROSE
GRİ	GRAY	GRAU	GRIGIO	GRIS	GRIS
TURUNCU	ORANGE	ORANGE	ARANCIONE	NARANJA	ORANGE
ŞEFFAF	TRANSPARENT	DURCHSICHTIG	TRANSPARENTE	TRANSPARENTE	TRANSPARENT
BEJ	BEIGE	BEIGE	BEIGE	BEIGE	BEIGE



EEM Imp. Exp. Trade Co.  
Lift Control Systems

Tel : +90.332. 342 41 27 - 28  
Fax : +90.332. 342 41 29

www.eem.com.tr

Project Name GİZMO Lift Control System

Drawing Name Vacon NXP Closed Loop Speed Control Device Encoder connection drawing with OPTA5 Encoder Card

Description

Version 3.2

Date 03.09.2008



Drawer ZD - BA

Control SH

Draw No: 2E Page 41

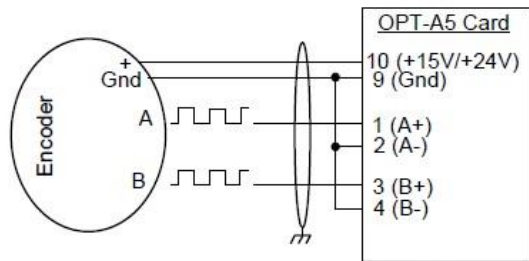

Open source, single ended encoder connection drawing.

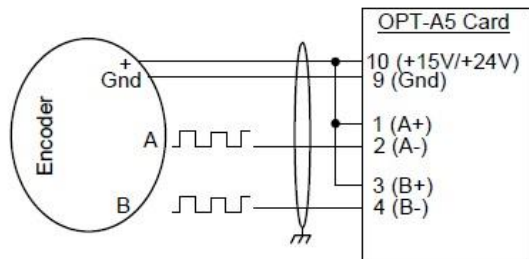

Open collector, single ended encoder connection drawing.

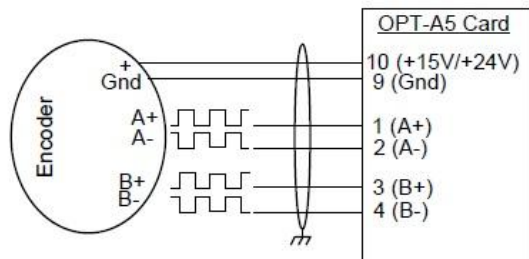

Differential input, line driver encoder connection drawing.

OPT-A5

- 1 ----- A+
- 2 ----- A-
- 3 ----- B+
- 4 ----- B-
- 9 ----- GND
- 10 ----- +15V/+24V

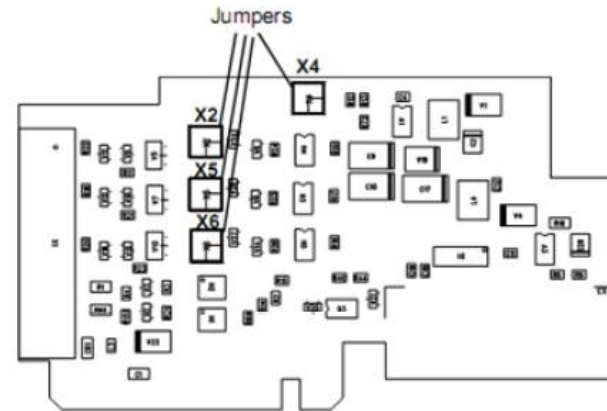
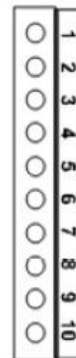

X4 Jumper setting:



Default Setting

- How can i understand that which encoder card is mounted to my speed control device?
- You can learn your mounted encoder card name (OPTA4 or OPTA5) by P7.3 parameter. If you see different name in this parameter, a different card may be integrated. If this parameter doesn't run, it means that, there is no integrated card on your device.

### MEANINGS OF COLORS IN DIFFERENT LANGUAGES

TURKISH	ENGLISH	GERMAN	ITALIAN	SPANISH	FRENCH
SİYAH	BLACK	SCHWARZ	NERO	NEGRO	NOIR
BEYAZ	WHITE	WEISS	BIANCO	BLANCO	BLANC
KIRMIZI	RED	ROT	ROSSO	ROJO	ROUGE
SARI	YELLOW	GELB	GIALLO	AMARILLO	JAUNE
MAVİ	BLUE	BLAU	BLU	AZUL	BLEU
YEŞİL	GREEN	GRÜN	VERDE	VERDE	VERT
KAHVERENGİ	BROWN	BRAUN	MARRONE	MARRON	BRUN
MOR	VIOLET	VIOLETT	VIOLA	VIOLETA	VIOLET
PEMBE	PINK	ROSA	ROSA	ROSA	ROSE
GRİ	GRAY	GRAU	GRIGIO	GRIS	GRIS
TURUNCU	ORANGE	ORANGE	ARANCIONE	NARANJA	ORANGE
ŞEFFAF	TRANSPARENT	DURCHSICHTIG	TRANSPARENTE	TRANSPARENTE	TRANSPARENT
BEJ	BEIGE	BEIGE	BEIGE	BEIGE	BEIGE



EEM Imp. Exp. Trade Co.  
Lift Control Systems

Tel : +90.332. 342 41 27 - 28  
Fax : +90.332. 342 41 29

www.eem.com.tr

Project Name GİZMO Lift Control System

Drawing Name Vacon NXP Closed Loop Speed Control Device Encoder connection drawing with OPTA5 Encoder Card

Description

Version 3.2

Date 03.09.2008



Drawer ZD - BA

Control SH

Draw No: 2E Page 41

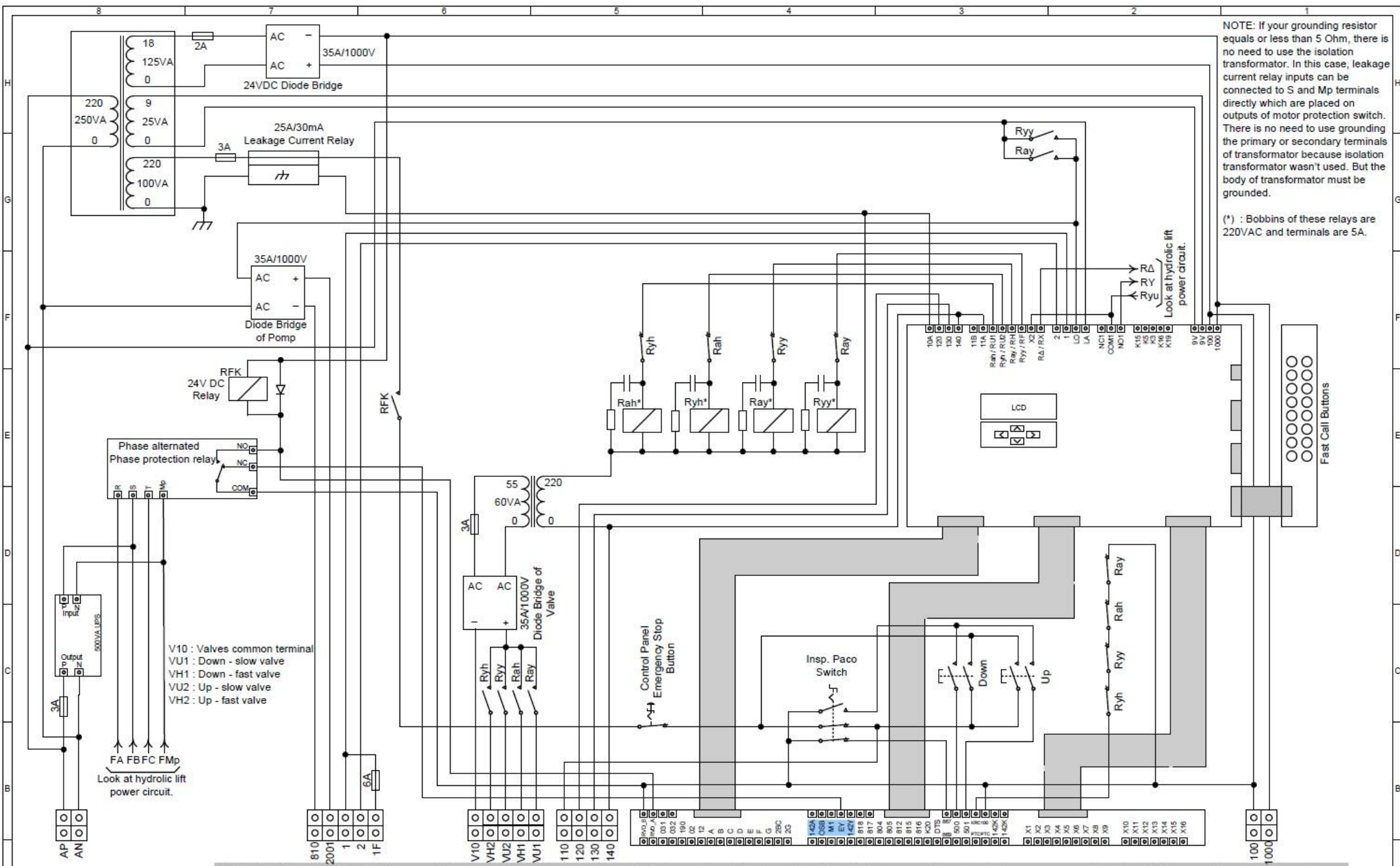

NOTE: If your grounding resistor equals or less than 5 Ohm, there is no need to use the isolation transformer. In this case, leakage current relay inputs can be connected to S and Mp terminals directly which are placed on outputs of motor protection switch. There is no need to use grounding the primary or secondary terminals of transformer because isolation transformer wasn't used. But the body of transformer must be grounded.

(\*) : Bobbins of these relays are 220VAC and terminals are 5A.

NOTE: Power circuit is on "Hydraulic Lift Power Circuit" drawing. Prefer the kind of operation to drive your motor by this mentioned drawing.



EEM Imp. Exp. Trade Co.  
Lift Control Systems

Tel : +90.332.342 41 27 - 28  
Fax : +90.332.342 41 29

www.eem.com.tr

Project Name	GİZMO Lift Control System
Drawing Name	48VDC Valve Klemann or Leistritz Hydraulic Unit, Rescued by UPS, Control Panel Connection Drawing
Description	

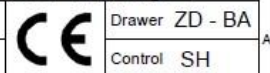

Version 3.2 Date 03.09.2008 Draw No: 3A Page 42

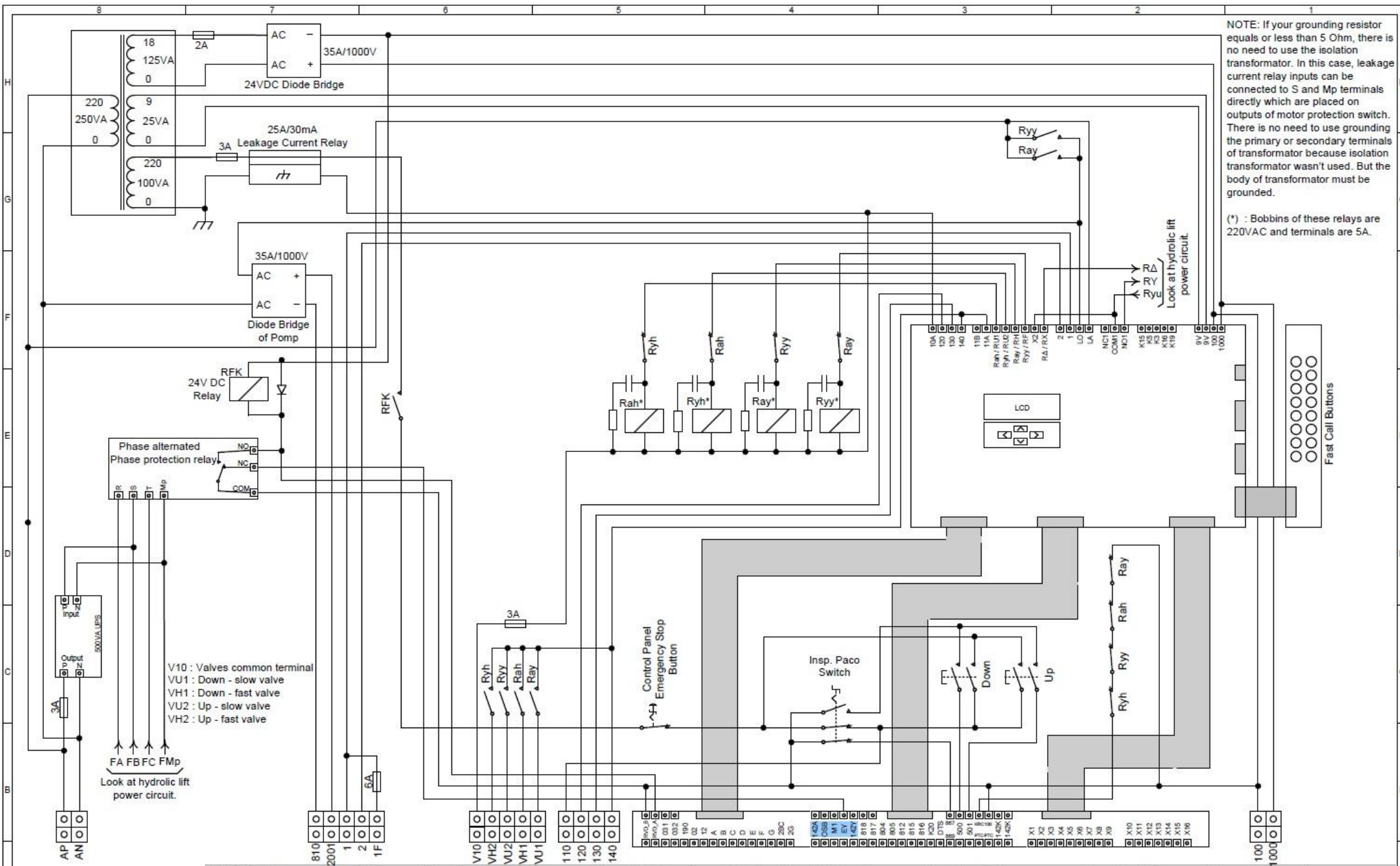

NOTE: If your grounding resistor equals or less than 5 Ohm, there is no need to use the isolation transformer. In this case, leakage current can be connected to S and Mp terminals directly which are placed on outputs of motor protection switch. There is no need to use grounding the primary or secondary terminals of transformer because isolation transformer wasn't used. But the body of transformer must be grounded.

(\*) : Bobbins of these relays are 220VAC and terminals are 5A.

NOTE: Power circuit is on "Hydraulic Lift Power Circuit" drawing. Prefer the kind of operation to drive your motor by this mentioned drawing.



EEM Imp. Exp. Trade Co.  
Lift Control Systems

Tel : +90.332.342 41 27 - 28  
Fax : +90.332.342 41 29

www.eem.com.tr

Project Name GIZMO Lift Control System

Drawing Name 220VAC Valve Klemann Hydraulic Unit, Rescued by UPS, Control Panel Connection Drawing

Description



Drawer ZD - BA

Control SH

Version 3.2

Date 03.09.2008

Draw No: 3B

Page 43

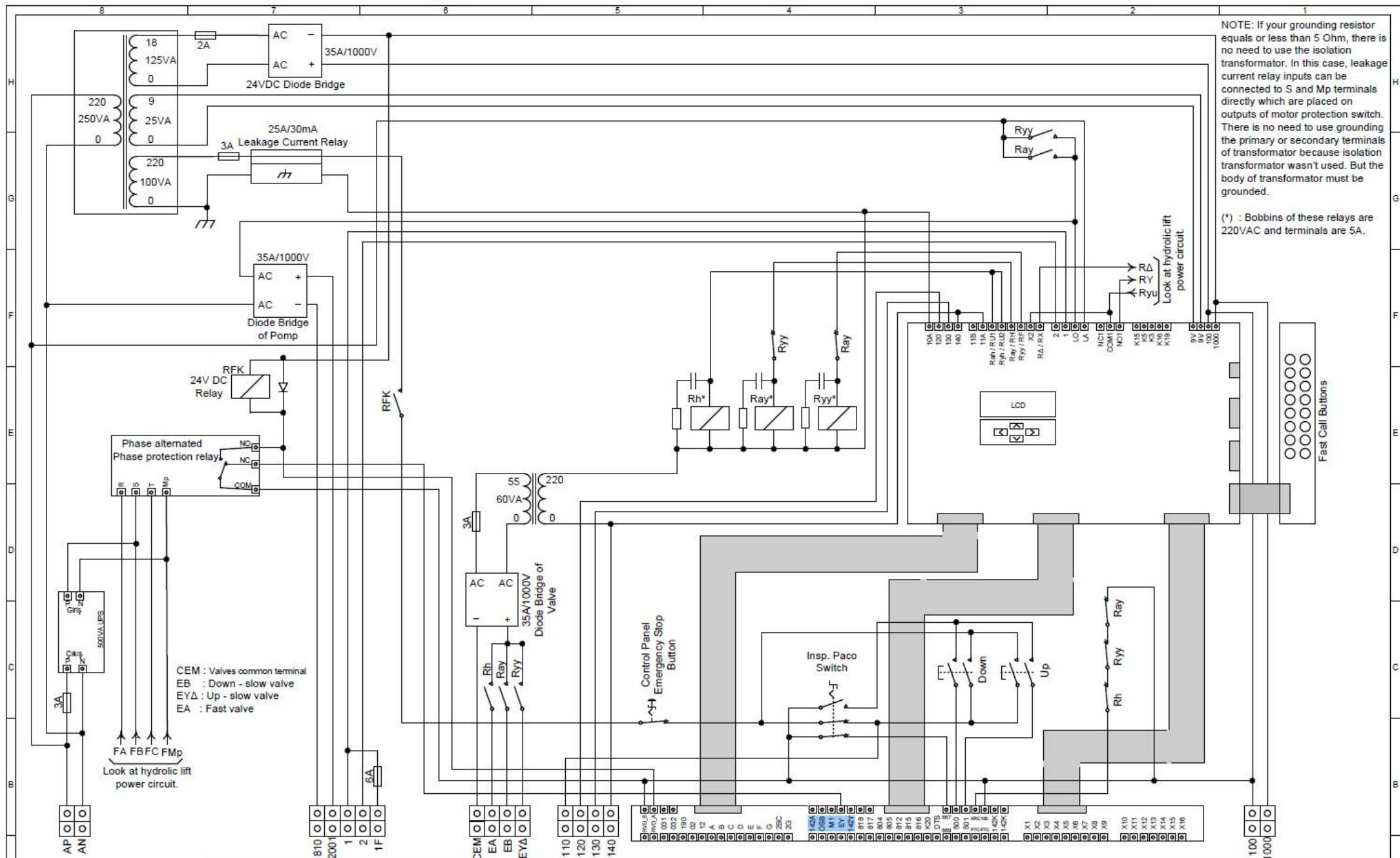

NOTE: If your grounding resistor equals or less than 5 Ohm, there is no need to use the isolation transformer. In this case, leakage current relay inputs can be connected to S and Mp terminals directly which are placed on outputs of motor protection switch. There is no need to use grounding the primary or secondary terminals of transformer because isolation transformer wasn't used. But the body of transformer must be grounded.

(\*) : Bobbins of these relays are 220VAC and terminals are 5A.

NOTE: Power circuit is on "Hydraulic Lift Power Circuit" drawing. Prefer the kind of operation to drive your motor by this mentioned drawing.



EEM Imp. Exp. Trade Co.  
Lift Control Systems

Tel : +90.332. 342 41 27 - 28  
Fax : +90.332. 342 41 29

www.eem.com.tr

Project Name GIZMO Lift Control System

Drawing Name Morris Hydraulic Unit, Rescued by UPS, Control Panel Connection Drawing

Description



Drawer ZD - BA

Control SH

Version 3.2

Date 03.09.2008

Draw No: 3C

Page 44

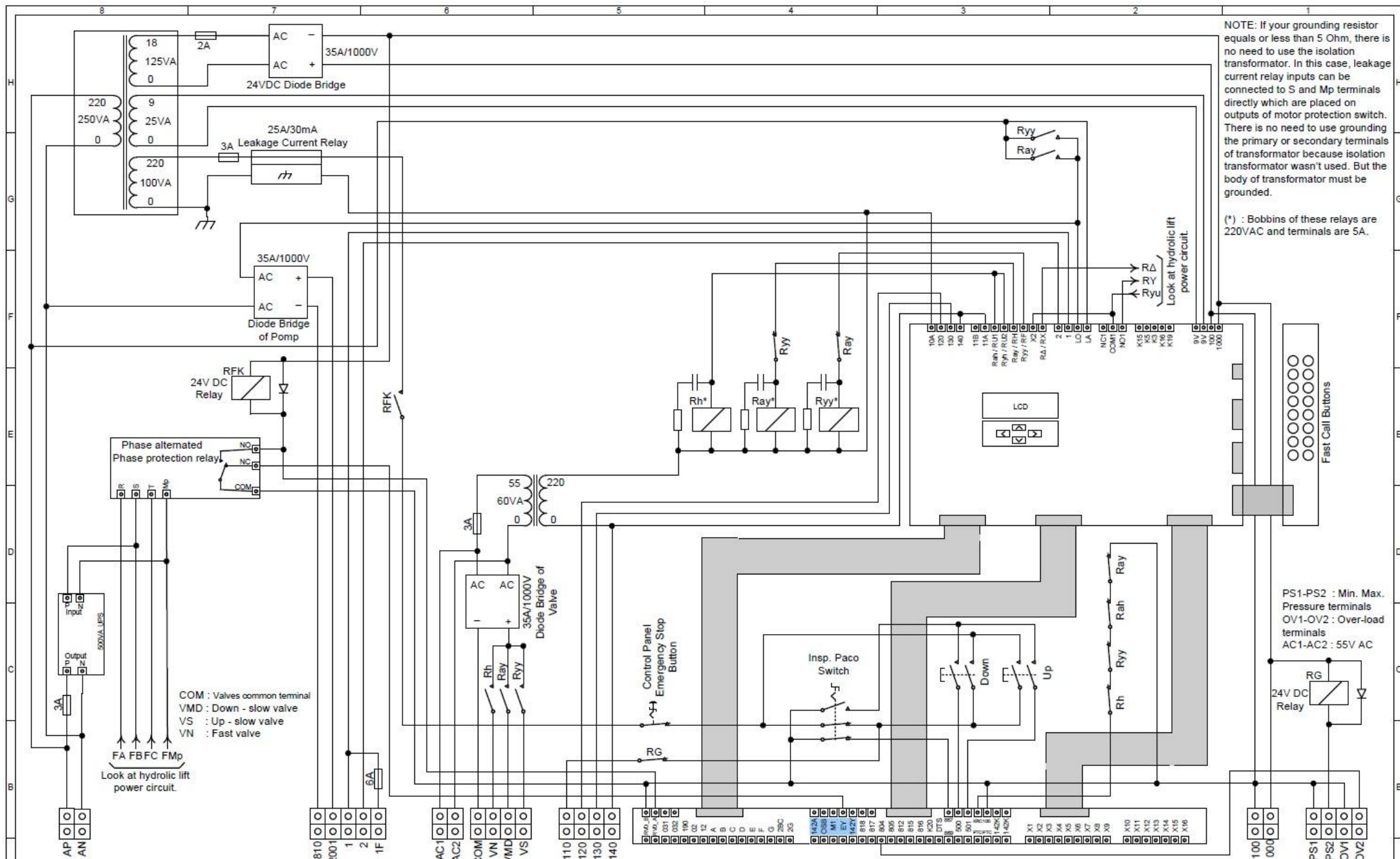

NOTE: If your grounding resistor equals or less than 5 Ohm, there is no need to use the isolation transformer. In this case, leakage current relay inputs can be connected to S and Mp terminals directly which are placed on outputs of motor protection switch. There is no need to use grounding the primary or secondary terminals of transformer because isolation transformer wasn't used. But the body of transformer must be grounded.

(\*) : Bobbins of these relays are 220VAC and terminals are 5A.

NOTE: Power circuit is on "Hydraulic Lift Power Circuit" drawing. Prefer the kind of operation to drive your motor by this mentioned drawing.



EEM Imp. Exp. Trade Co.  
Lift Control Systems

Tel : +90.332.342 41 27 - 28  
Fax : +90.332.342 41 29

www.eem.com.tr

Project Name	GIZMO Lift Control System	Version 3.2	Date 03.09.2008	Draw No: 3D	Page 45
Drawing Name	GMV Hydraulic Unit, Rescued by UPS, Control Panel Connection Drawing				
Description					
		Drawer ZD - BA			
		Control SH			

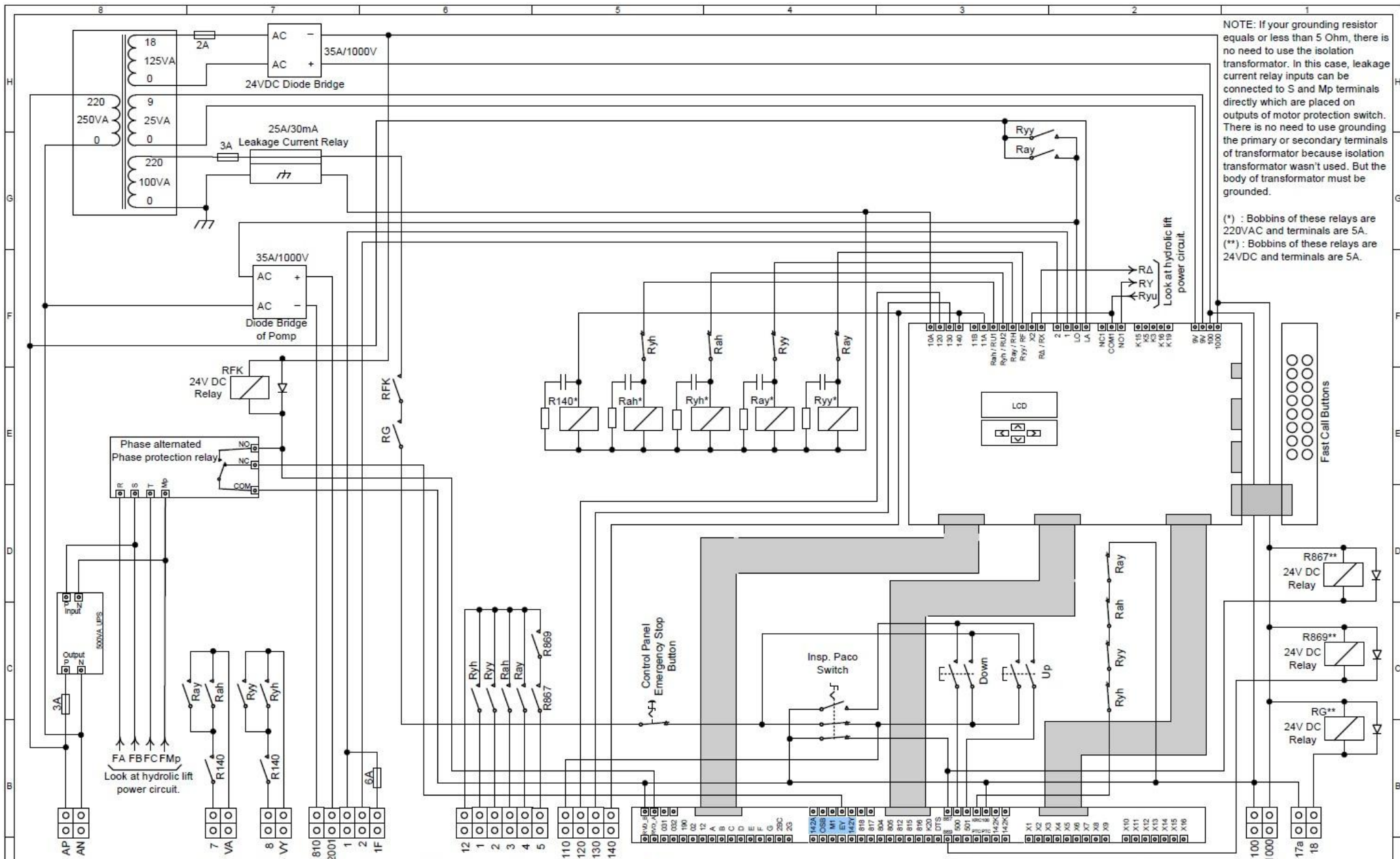

NOTE: If your grounding resistor equals or less than 5 Ohm, there is no need to use the isolation transformer. In this case, leakage current relay inputs can be connected to S and Mp terminals directly which are placed on outputs of motor protection switch. There is no need to use grounding the primary or secondary terminals of transformer because isolation transformer wasn't used. But the body of transformer must be grounded.

(\*) : Bobbins of these relays are 220VAC and terminals are 5A.  
 (\*\*): Bobbins of these relays are 24VDC and terminals are 5A.

NOTE: Power circuit is on "Hydraulic Lift Power Circuit" drawing. Prefer the kind of operation to drive your motor by this mentioned drawing.



EEM Imp. Exp. Trade Co.  
Lift Control Systems

Tel : +90.332. 342 41 27 - 28  
Fax : +90.332. 342 41 29

www.eem.com.tr

Project Name GIZMO Lift Control System  
 Drawing Name Beringer Hydraulic Unit, Rescued by UPS, Control Panel Connection Drawing  
 Description

CE  
 Drawer ZD - BA  
 Control SH

Version 3.2 Date 03.09.2008 Draw No: 3E Page 46

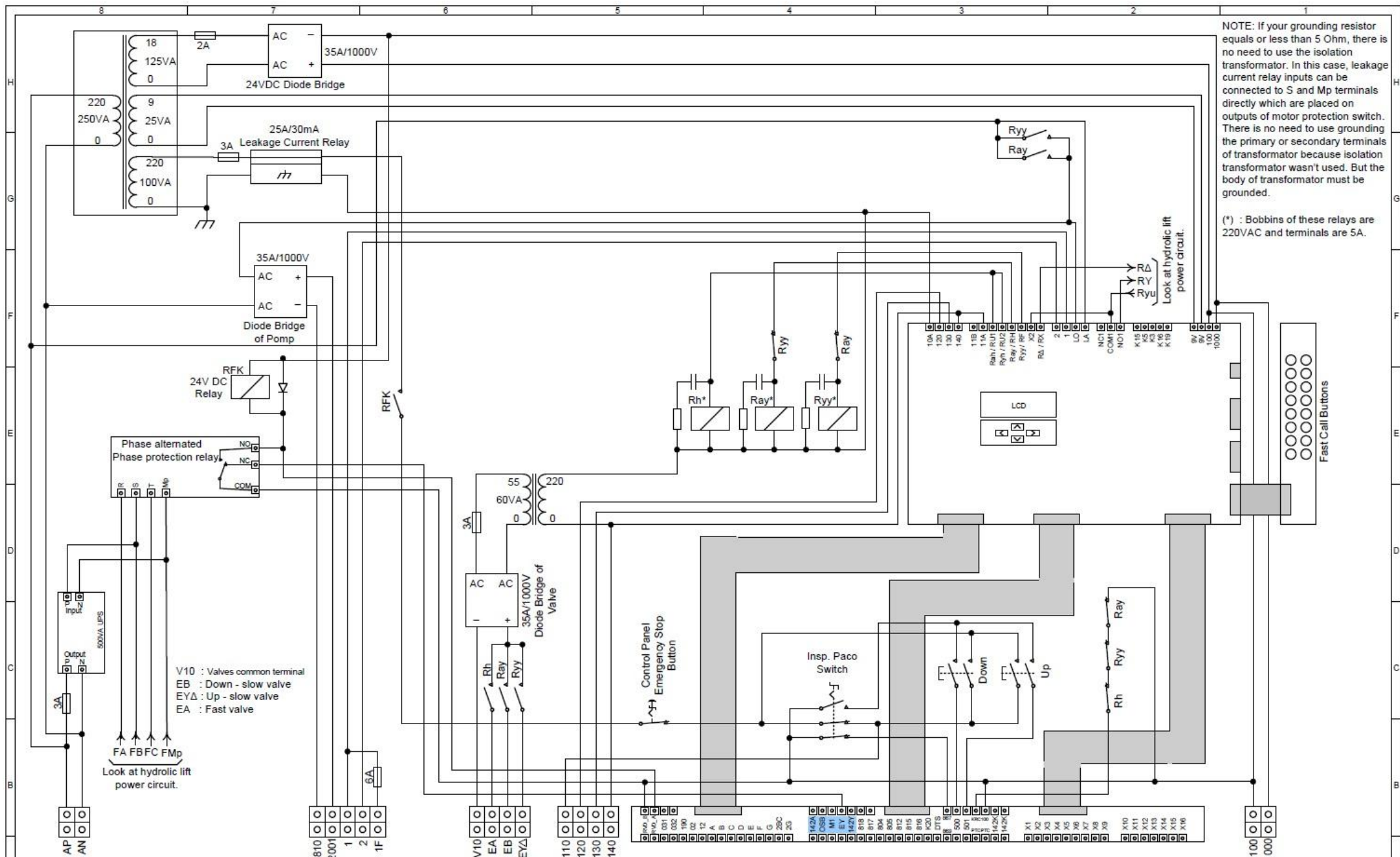

NOTE: Power circuit is on "Hydrolic Lift Power Circuit" drawing. Prefer the kind of operation to drive your motor by this mentioned drawing.



EEM Imp. Exp. Trade Co.  
 Lift Control Systems

Tel : +90.332. 342 41 27 - 28  
 Fax : +90.332. 342 41 29

www.eem.com.tr

Project Name GIZMO Lift Control System

Drawing Name Sodimas Hydrolic Unit, Rescued by UPS, Control Panel Connection Drawing

Description



Drawer ZD - BA  
 Control SH

Version 3.2

Date 03.09.2008

Draw No: 3F

Page 47

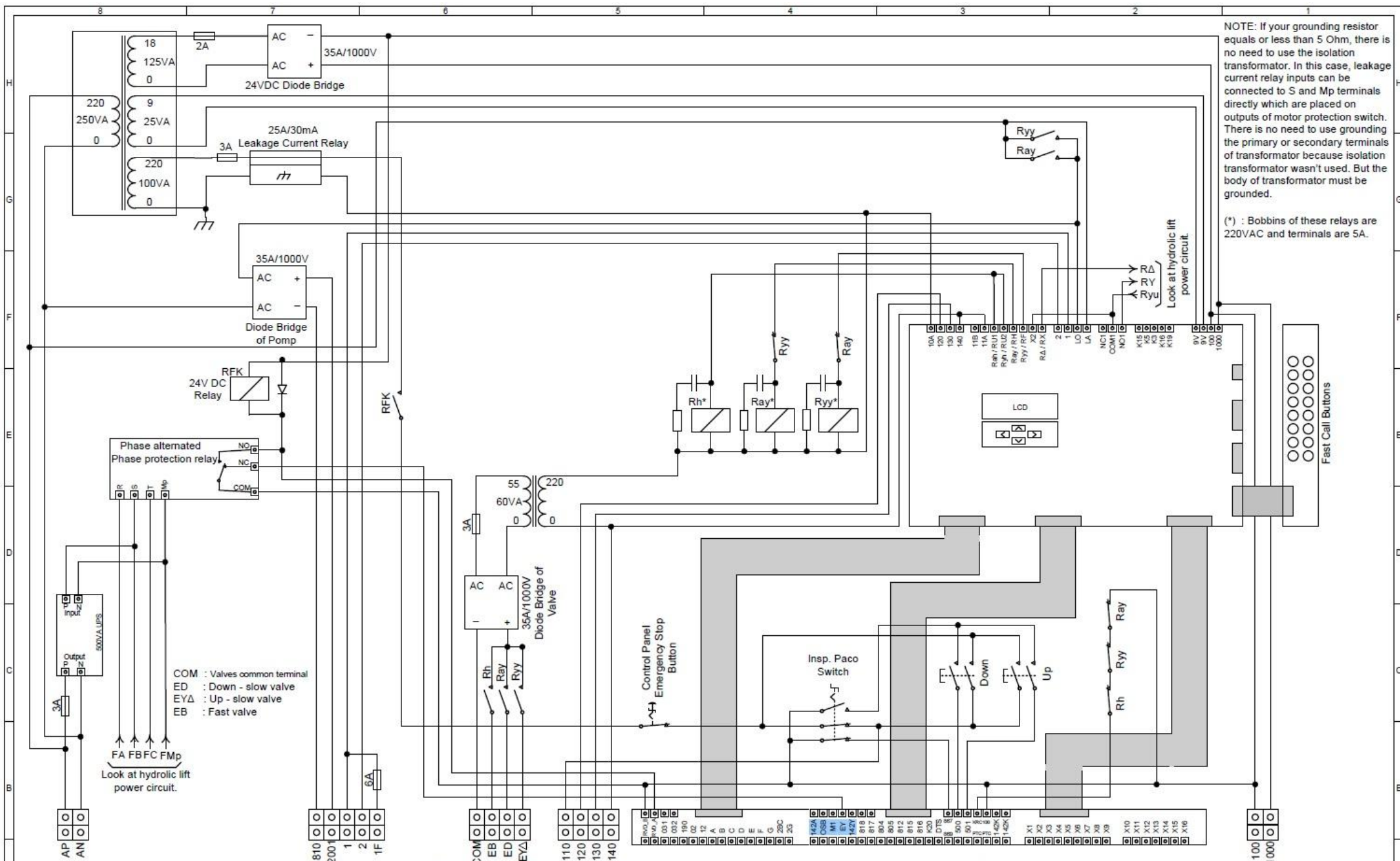

NOTE: If your grounding resistor equals or less than 5 Ohm, there is no need to use the isolation transformer. In this case, leakage current relay inputs can be connected to S and Mp terminals directly which are placed on outputs of motor protection switch. There is no need to use grounding the primary or secondary terminals of transformer because isolation transformer wasn't used. But the body of transformer must be grounded.

(\*) : Bobbins of these relays are 220VAC and terminals are 5A.

NOTE: Power circuit is on "Hydraulic Lift Power Circuit" drawing. Prefer the kind of operation to drive your motor by this mentioned drawing.



EEM Imp. Exp. Trade Co.  
Lift Control Systems

Tel : +90.332.342 41 27 - 28  
Fax : +90.332.342 41 29

www.eem.com.tr

Project Name	GIZMO Lift Control System	CE	Drawer	ZD - BA					
Drawing Name	IGV Hydraulic Unit, Rescued by UPS, Control Panel Connection Drawing		Control	SH					
Description		Version	3.2	Date	03.09.2008	Draw No:	3G	Page	48

Look at to the control scheme according to the brand of used unit.

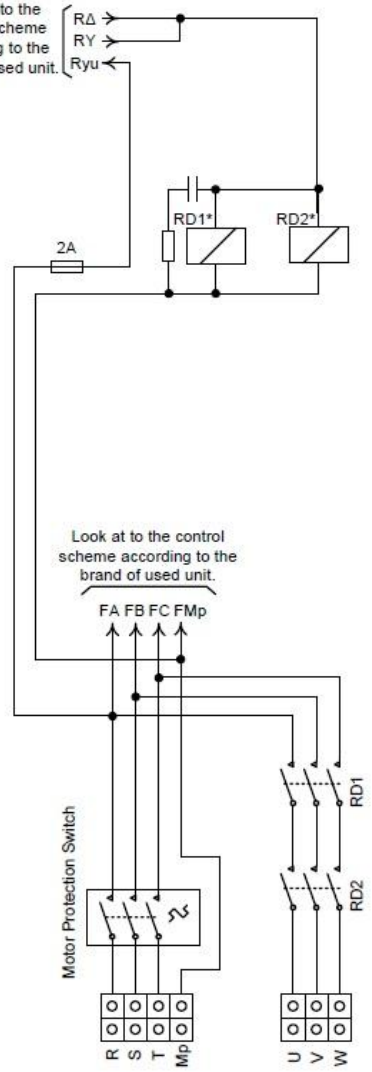

DIRECT DRIVE

Look at to the control scheme according to the brand of used unit.

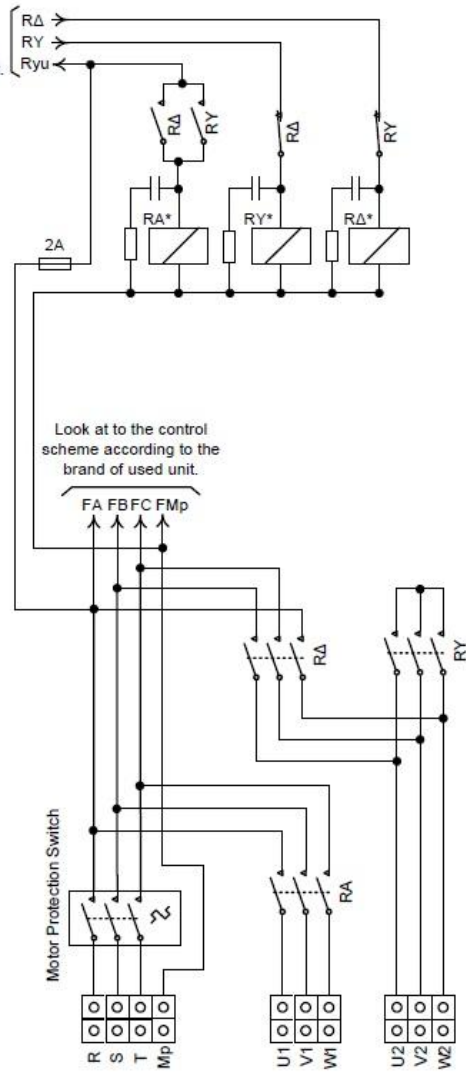

DRIVEN BY STAR-DELTA

Look at to the control scheme according to the brand of used unit.

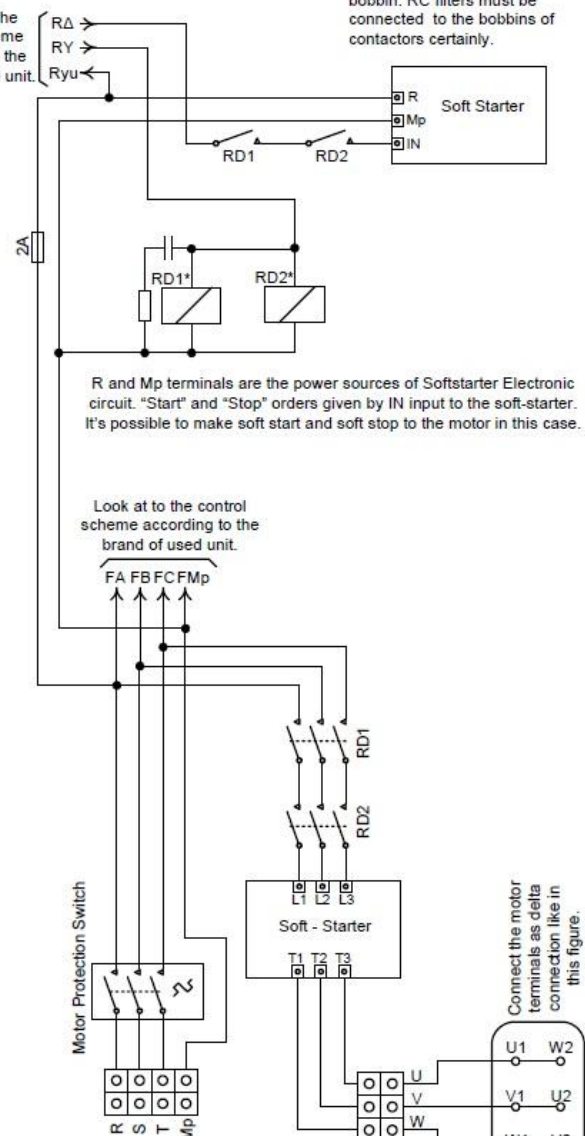

DRIVEN BY SOFT-STARTER

**WARNING : BE SURE ABOUT THE LIFT TYPE ON GIZMO CONTROL CARD IS SELECTED AS HYDROLIC-STAR/DELTA. OTHERWISE FATAL ERRORS MAY OCCUR. ALSO SOME PERMANENT DAMAGES MAY OCCUR ON THE CONTROL PANEL.**



**WARNING : BE SURE ABOUT THE LIFT TYPE ON GIZMO CONTROL CARD IS SELECTED AS HYDROLIC-SOFTSTARTER. OTHERWISE FATAL ERRORS MAY OCCUR. ALSO SOME PERMANENT DAMAGES MAY OCCUR ON THE CONTROL PANEL.**



Connect the motor terminals as delta connection like in this figure.



EEM Imp. Exp. Trade Co.  
Lift Control Systems

Tel : +90.332.342 41 27 - 28  
Fax : +90.332.342 41 29

www.eem.com.tr

Project Name GIZMO Lift Control System

Drawing Name Hydraulic Lift Power Circuit (Direct Drive, Driven by Star-Delta, Driven by Soft Starter)

Description

Version 3.2

Date 03.09.2008

Draw No: 3Y

Page 49



Drawer ZD - BA

Control SH

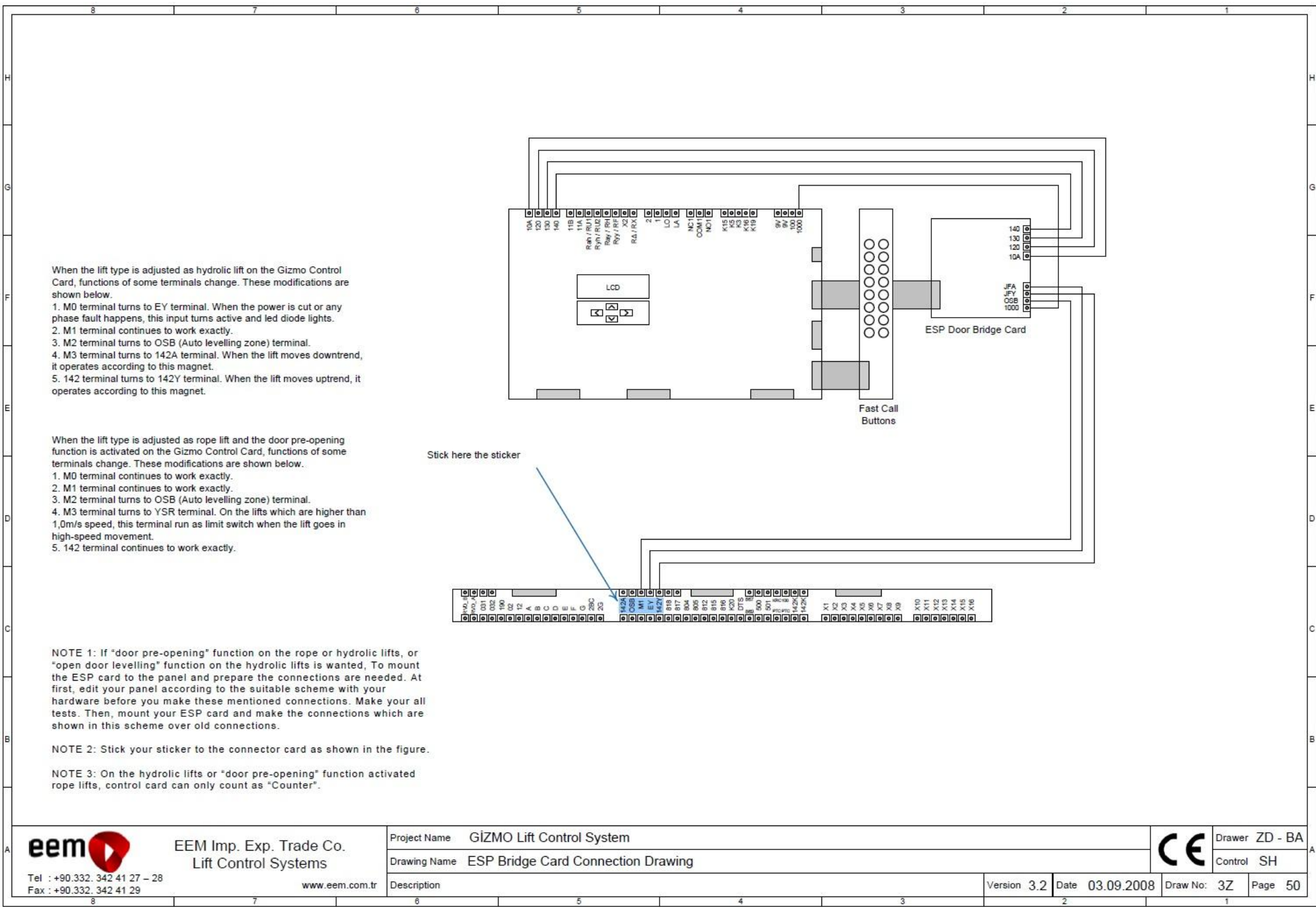

When the lift type is adjusted as hydrolic lift on the Gizmo Control Card, functions of some terminals change. These modifications are shown below.

1. M0 terminal turns to EY terminal. When the power is cut or any phase fault happens, this input turns active and led diode lights.
2. M1 terminal continues to work exactly.
3. M2 terminal turns to OSB (Auto levelling zone) terminal.
4. M3 terminal turns to 142A terminal. When the lift moves downtrend, it operates according to this magnet.
5. 142 terminal turns to 142Y terminal. When the lift moves uptrend, it operates according to this magnet.

When the lift type is adjusted as rope lift and the door pre-opening function is activated on the Gizmo Control Card, functions of some terminals change. These modifications are shown below.

1. M0 terminal continues to work exactly.
2. M1 terminal continues to work exactly.
3. M2 terminal turns to OSB (Auto levelling zone) terminal.
4. M3 terminal turns to YSR terminal. On the lifts which are higher than 1,0m/s speed, this terminal run as limit switch when the lift goes in high-speed movement.
5. 142 terminal continues to work exactly.

Stick here the sticker

NOTE 1: If "door pre-opening" function on the rope or hydrolic lifts, or "open door levelling" function on the hydrolic lifts is wanted, To mount the ESP card to the panel and prepare the connections are needed. At first, edit your panel according to the suitable scheme with your hardware before you make these mentioned connections. Make your all tests. Then, mount your ESP card and make the connections which are shown in this scheme over old connections.

NOTE 2: Stick your sticker to the connector card as shown in the figure.

NOTE 3: On the hydrolic lifts or "door pre-opening" function activated rope lifts, control card can only count as "Counter".



EEM Imp. Exp. Trade Co.  
Lift Control Systems

Tel : +90.332. 342 41 27 – 28  
Fax : +90.332. 342 41 29

www.eem.com.tr

Project Name	GizMO Lift Control System
Drawing Name	ESP Bridge Card Connection Drawing
Description	



Drawer ZD - BA  
Control SH

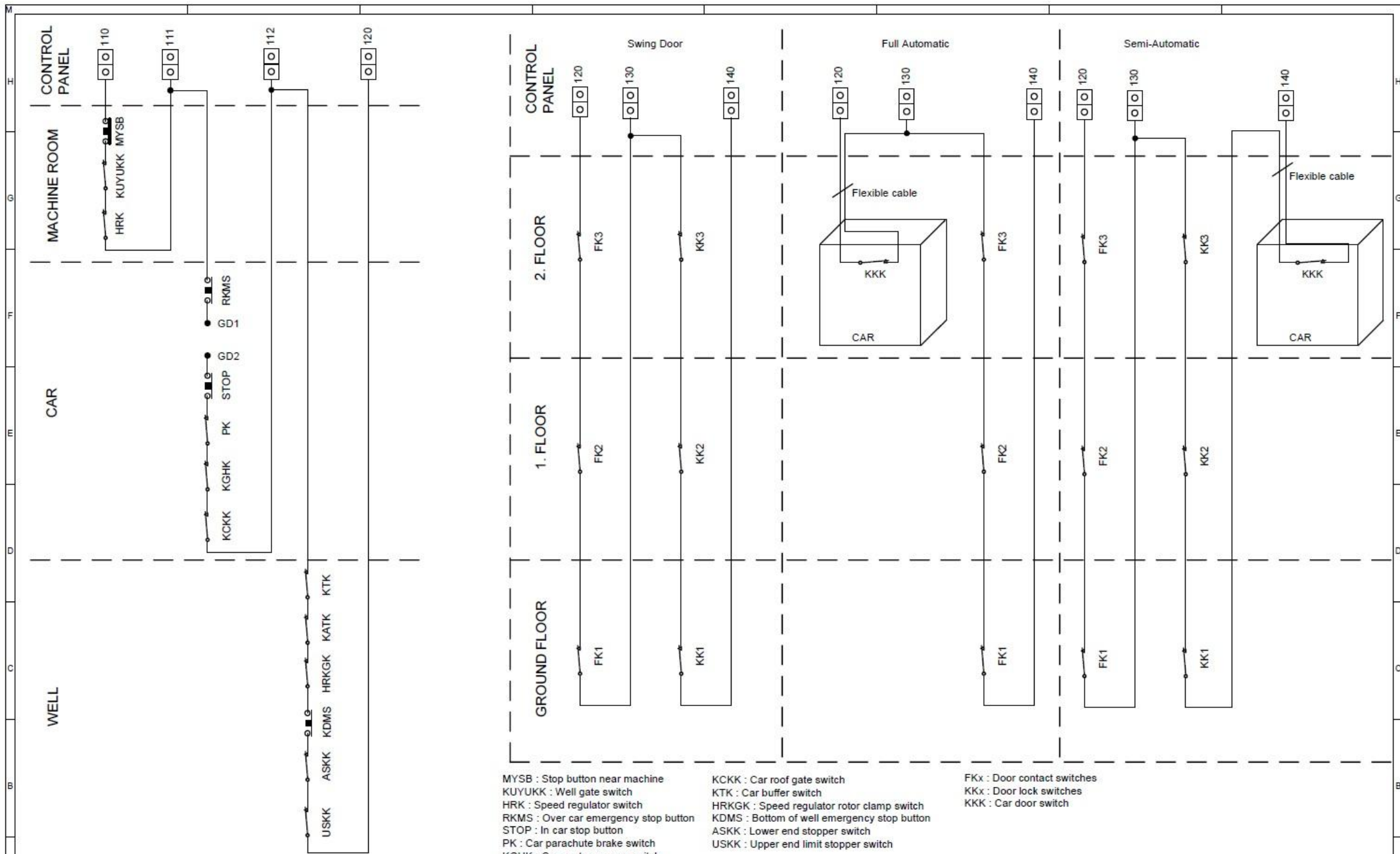

EEM Imp. Exp. Trade Co.  
Lift Control Systems

Tel : +90.332. 342 41 27 - 28  
Fax : +90.332. 342 41 29

www.eem.com.tr

Project Name GİZMO Lift Control System

Drawing Name Security circuit connections

Description



Drawer ZD - BA  
Control SH

Version 3.2

Date 03.09.2008

Draw No: 4A

Page 51

8

7

6

5

4

3

2

1

NOTE: To use parallel installed display outputs, adjust "P3.2-Display Output Type" parameter as "7 Segments".

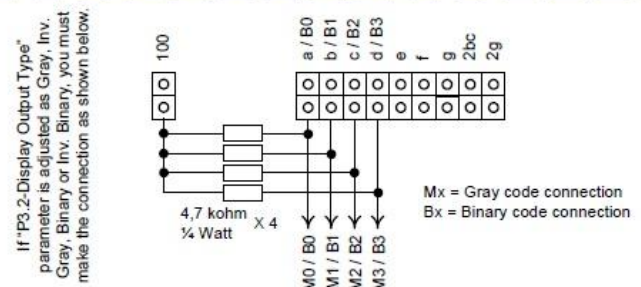
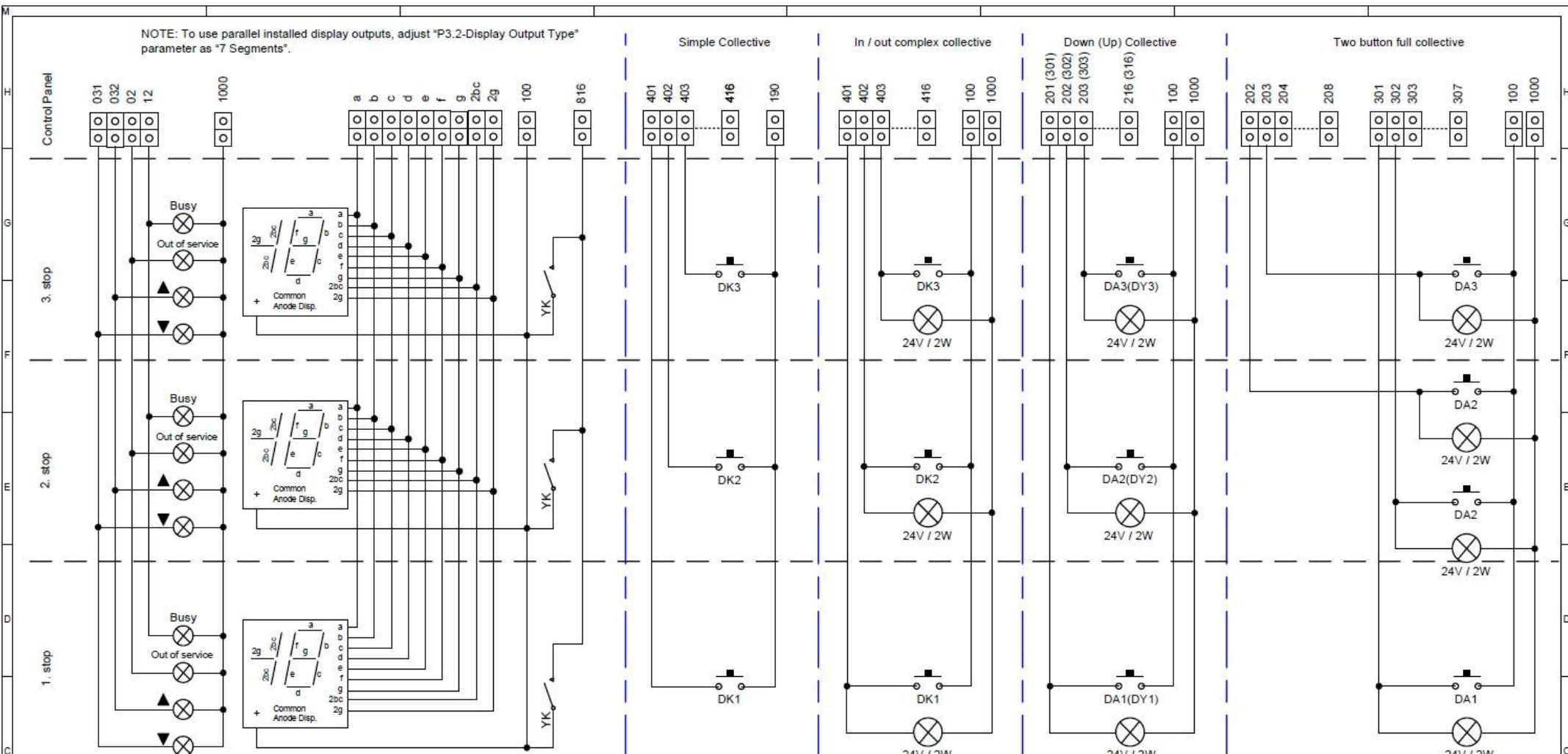

DKx : Call buttons and lamps  
 DAx : Down call buttons and lamps  
 DYx : Up call buttons and lamps  
 SDS : Out of service lamp  
 YK : Fire switch

: 24V, max 2W lamp

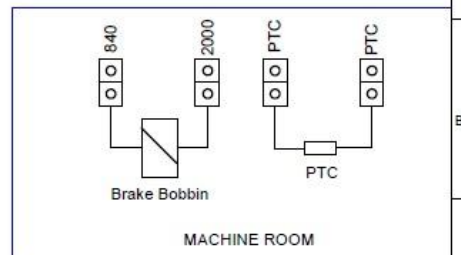

EEM Imp. Exp. Trade Co.  
Lift Control Systems

Tel : +90.332. 342 41 27 – 28  
Fax : +90.332. 342 41 29

www.eem.com.tr

Project Name GIZMO Lift Control System

Drawing Name Floor installation, brake, motor, thermistor connections

Description

CE  
Drawer ZD - BA  
Control SH

Version 3.2 Date 03.09.2008 Draw No: 4B Page 52

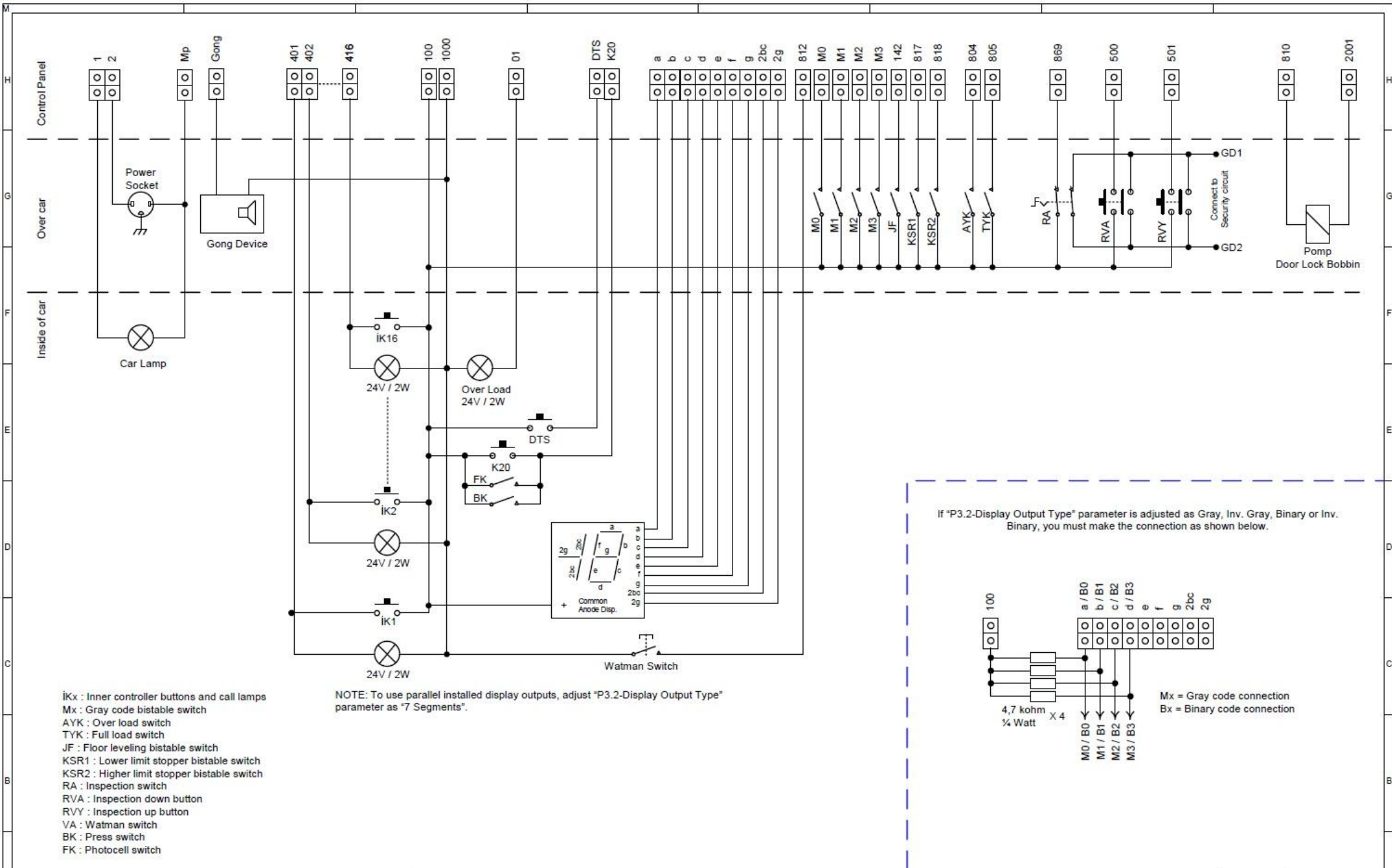

EEM Imp. Exp. Trade Co.  
Lift Control Systems

Tel : +90.332. 342 41 27 – 28  
Fax : +90.332. 342 41 29

www.eem.com.tr

Project Name GIZMO Lift Control System

Drawing Name Car Installation

Description



Drawer ZD - BA  
Control SH

Version 3.2

Date 03.09.2008

Draw No: 4C

Page 53

8

7

6

5

4

3

2

1

**1. AUTO-DOOR CARD CONNECTION WHICH OPERATES BY PUMP SIGNAL**

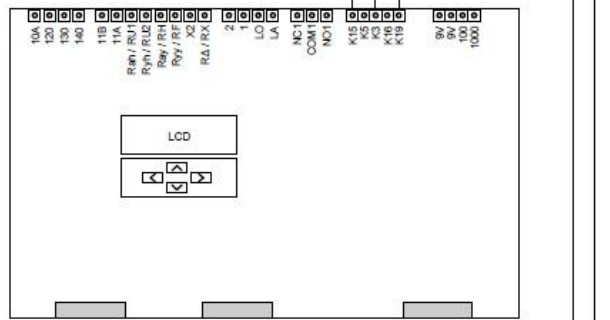

100 ←  
R (AP) ←  
Mp (AN) ←

NOTE: On hydrolic lifts, use AP and AN terminals which are shown in paranthesis.

**2. 3 PHASES 380V MOTORIZED AUTO-DOOR CARD CONNECTION WITHOUT CONTROL CARD**

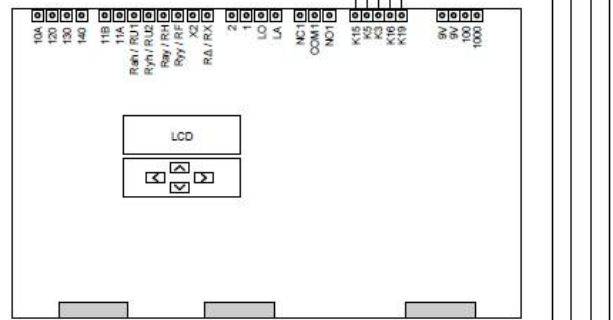

\* : Bobbins of these contactors must be AC-3 class 220VAC bobbin. RC filters must be connected certainly.

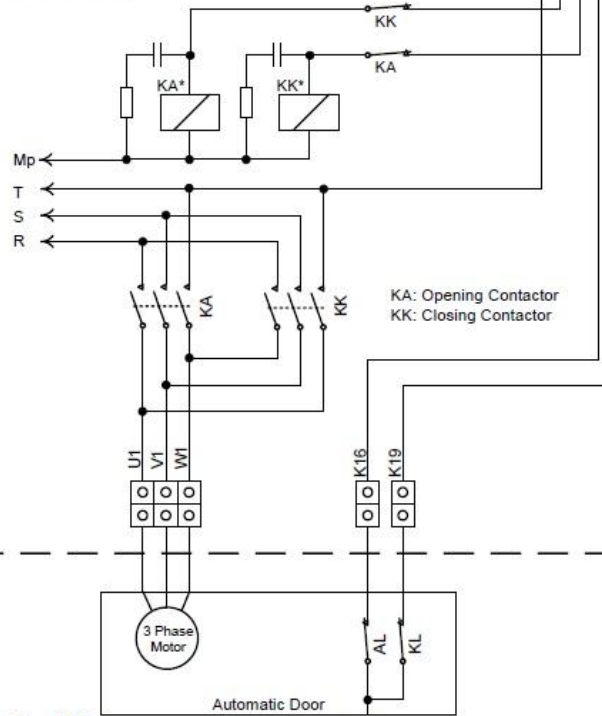

AL: Open Limit  
KL: Close Limit

**3. AUTO-DOOR CARD CONNECTION WITH CONTROL CARD**

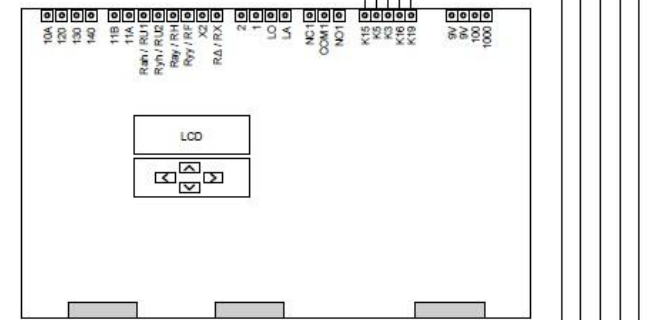

NOTE: On hydrolic lifts, use AP and AN terminals which are shown in paranthesis.

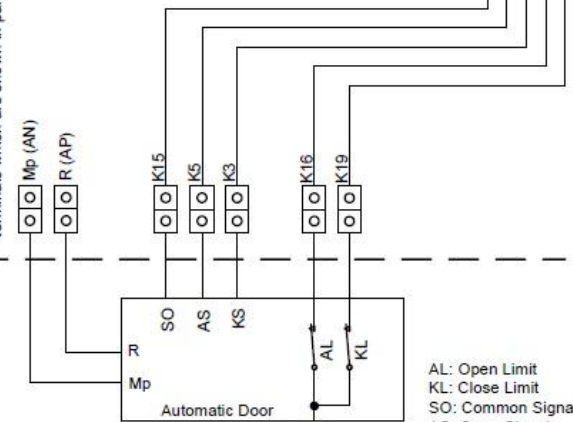

AL: Open Limit  
KL: Close Limit  
SO: Common Signal  
AS: Open Signal  
KS: Close Signal

CONTROL PANEL

OVER THE CAR



EEM Imp. Exp. Trade Co.  
Lift Control Systems

Tel : +90.332.342 41 27 - 28  
Fax : +90.332.342 41 29

www.eem.com.tr

Project Name GIZMO Lift Control System

Drawing Name Door card connection

Description



Drawer ZD - BA

Control SH

Version 3.2

Date 03.09.2008

Draw No: 4D

Page 54

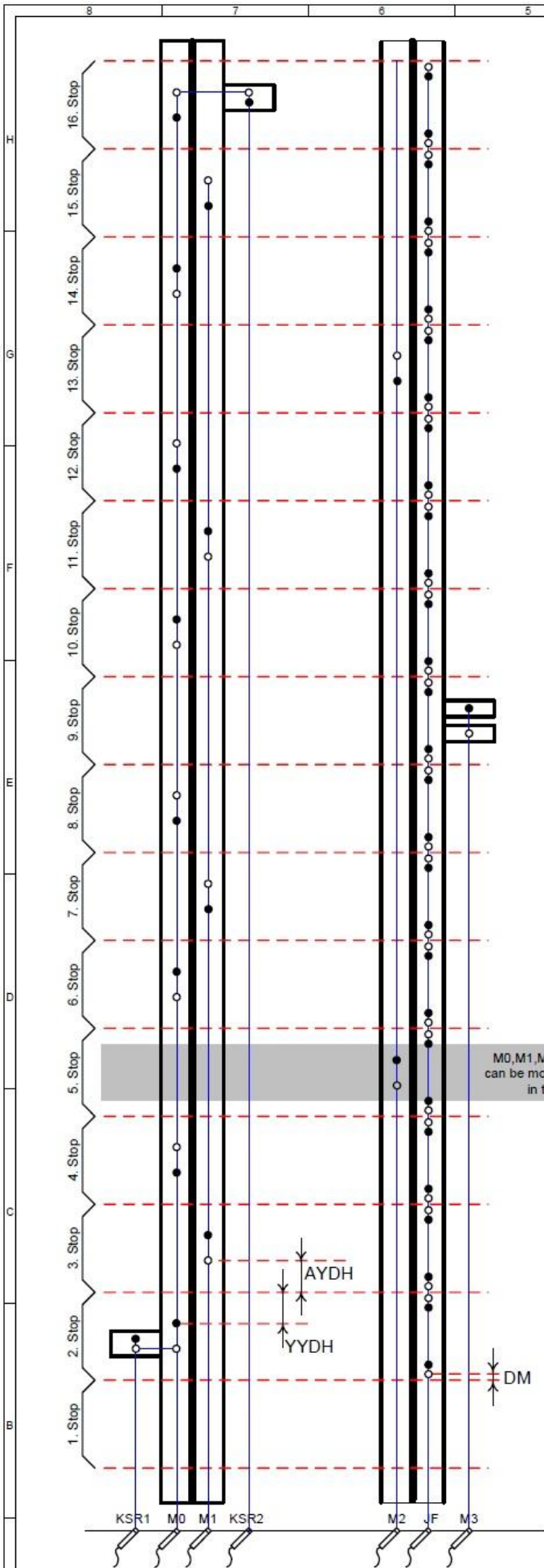

Gizmo control card LED informations

Stop	M3	M2	M1	M0	817	818
16	●	○	○	○	●	○
15	●	○	○	●	●	●
14	●	○	●	●	●	●
13	●	○	●	○	●	●
12	●	●	●	○	●	●
11	●	●	●	●	●	●
10	●	●	○	●	●	●
9	●	●	○	○	●	●
8	○	●	○	○	●	●
7	○	●	○	●	●	●
6	○	●	●	●	●	●
5	○	●	●	○	●	●
4	○	○	●	○	●	●
3	○	○	●	●	●	●
2	○	○	○	●	●	●
1	○	○	○	○	○	●

M0, M1, M2, M3 magnets can be mounted anywhere in this zone.

- M0 : Gray code bi-stable switch
- M1 : Gray code bi-stable switch
- M2 : Gray code bi-stable switch
- M3 : Gray code bi-stable switch
- JF : Floor leveling bi-stable switch
- KSR1 : Lower limit stopper bi-stable switch
- KSR2 : Higher limit stopper bi-stable switch
- DM : Stopping distance
- AYDH : Low speed distance for down direction
- YYDH : Low speed distance for up direction

- : Bi-stable switch at on state (The led on the controller is light off)
- : Bi-stable switch at off state (The led on the controller is light on)

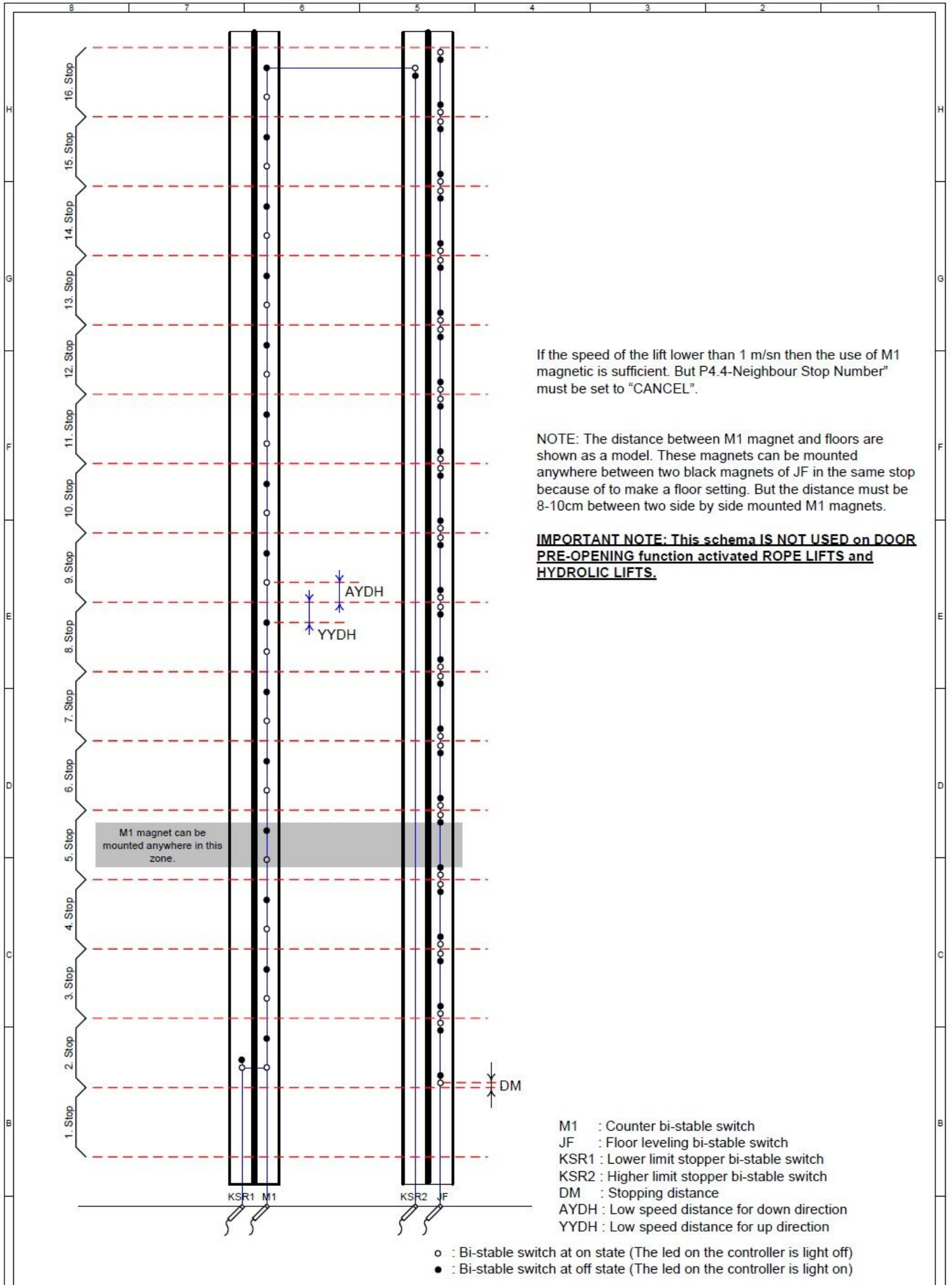

If the speed of the lift lower than 1 m/sn then the use of M1 magnetic is sufficient. But P4.4-Neighbour Stop Number" must be set to "CANCEL".

NOTE: The distance between M1 magnet and floors are shown as a model. These magnets can be mounted anywhere between two black magnets of JF in the same stop because of to make a floor setting. But the distance must be 8-10cm between two side by side mounted M1 magnets.

**IMPORTANT NOTE: This schema IS NOT USED on DOOR PRE-OPENING function activated ROPE LIFTS and HYDROLIC LIFTS.**

- M1 : Counter bi-stable switch
- JF : Floor leveling bi-stable switch
- KSR1 : Lower limit stopper bi-stable switch
- KSR2 : Higher limit stopper bi-stable switch
- DM : Stopping distance
- AYDH : Low speed distance for down direction
- YYDH : Low speed distance for up direction

- : Bi-stable switch at on state (The led on the controller is light off)
- : Bi-stable switch at off state (The led on the controller is light on)

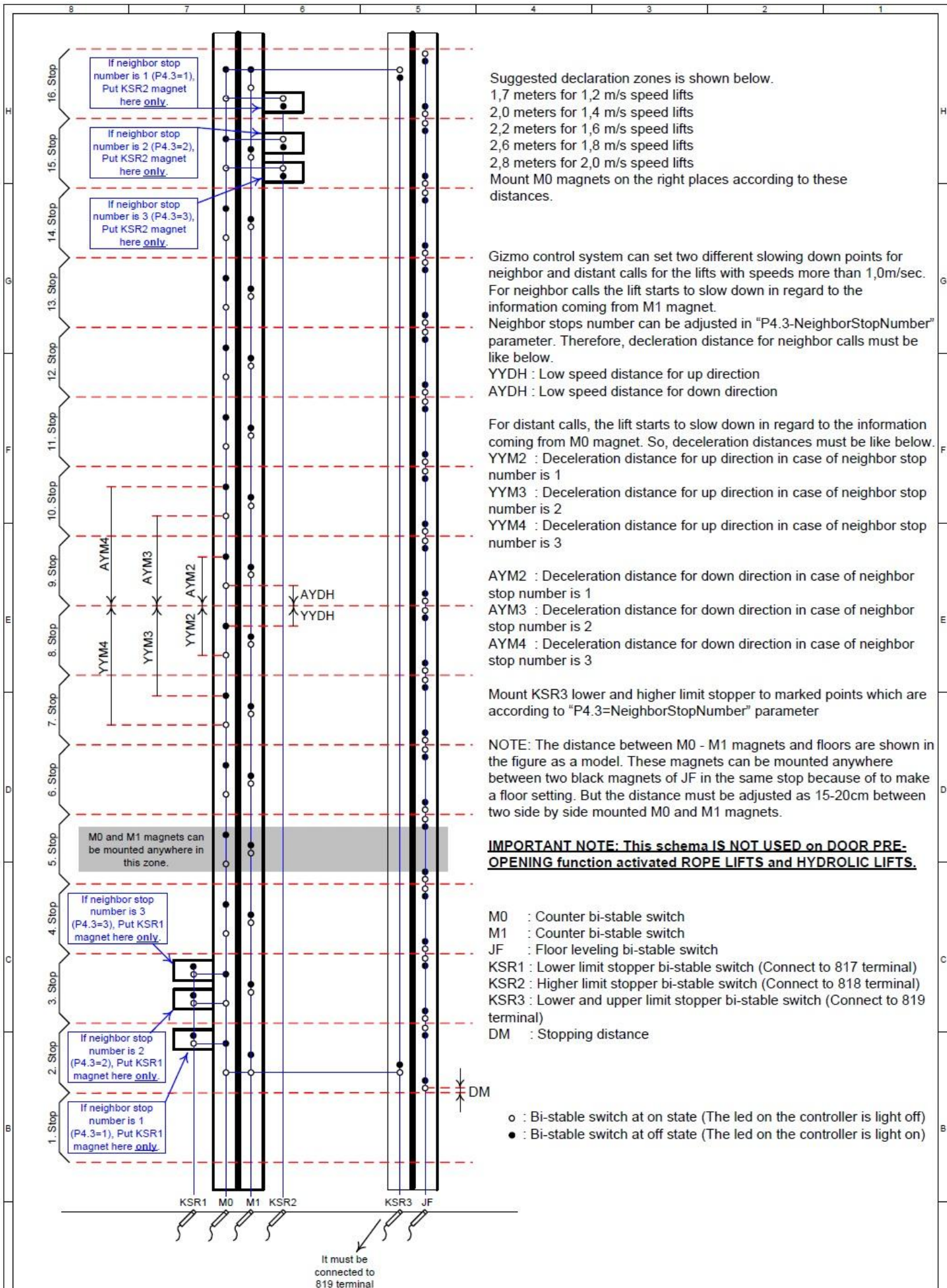

Suggested declaration zones is shown below.  
 1,7 meters for 1,2 m/s speed lifts  
 2,0 meters for 1,4 m/s speed lifts  
 2,2 meters for 1,6 m/s speed lifts  
 2,6 meters for 1,8 m/s speed lifts  
 2,8 meters for 2,0 m/s speed lifts  
 Mount M0 magnets on the right places according to these distances.

Gizmo control system can set two different slowing down points for neighbor and distant calls for the lifts with speeds more than 1,0m/sec. For neighbor calls the lift starts to slow down in regard to the information coming from M1 magnet. Neighbor stops number can be adjusted in "P4.3-NeighborStopNumber" parameter. Therefore, deceleration distance for neighbor calls must be like below.  
 YYDH : Low speed distance for up direction  
 AYDH : Low speed distance for down direction

For distant calls, the lift starts to slow down in regard to the information coming from M0 magnet. So, deceleration distances must be like below.  
 YYM2 : Deceleration distance for up direction in case of neighbor stop number is 1  
 YYM3 : Deceleration distance for up direction in case of neighbor stop number is 2  
 YYM4 : Deceleration distance for up direction in case of neighbor stop number is 3

AYM2 : Deceleration distance for down direction in case of neighbor stop number is 1  
 AYM3 : Deceleration distance for down direction in case of neighbor stop number is 2  
 AYM4 : Deceleration distance for down direction in case of neighbor stop number is 3

Mount KSR3 lower and higher limit stopper to marked points which are according to "P4.3=NeighborStopNumber" parameter

NOTE: The distance between M0 - M1 magnets and floors are shown in the figure as a model. These magnets can be mounted anywhere between two black magnets of JF in the same stop because of to make a floor setting. But the distance must be adjusted as 15-20cm between two side by side mounted M0 and M1 magnets.

**IMPORTANT NOTE: This schema IS NOT USED on DOOR PRE-OPENING function activated ROPE LIFTS and HYDROLIC LIFTS.**

- M0 : Counter bi-stable switch
- M1 : Counter bi-stable switch
- JF : Floor leveling bi-stable switch
- KSR1 : Lower limit stopper bi-stable switch (Connect to 817 terminal)
- KSR2 : Higher limit stopper bi-stable switch (Connect to 818 terminal)
- KSR3 : Lower and upper limit stopper bi-stable switch (Connect to 819 terminal)
- DM : Stopping distance

- : Bi-stable switch at on state (The led on the controller is light off)
- : Bi-stable switch at off state (The led on the controller is light on)

It must be connected to 819 terminal

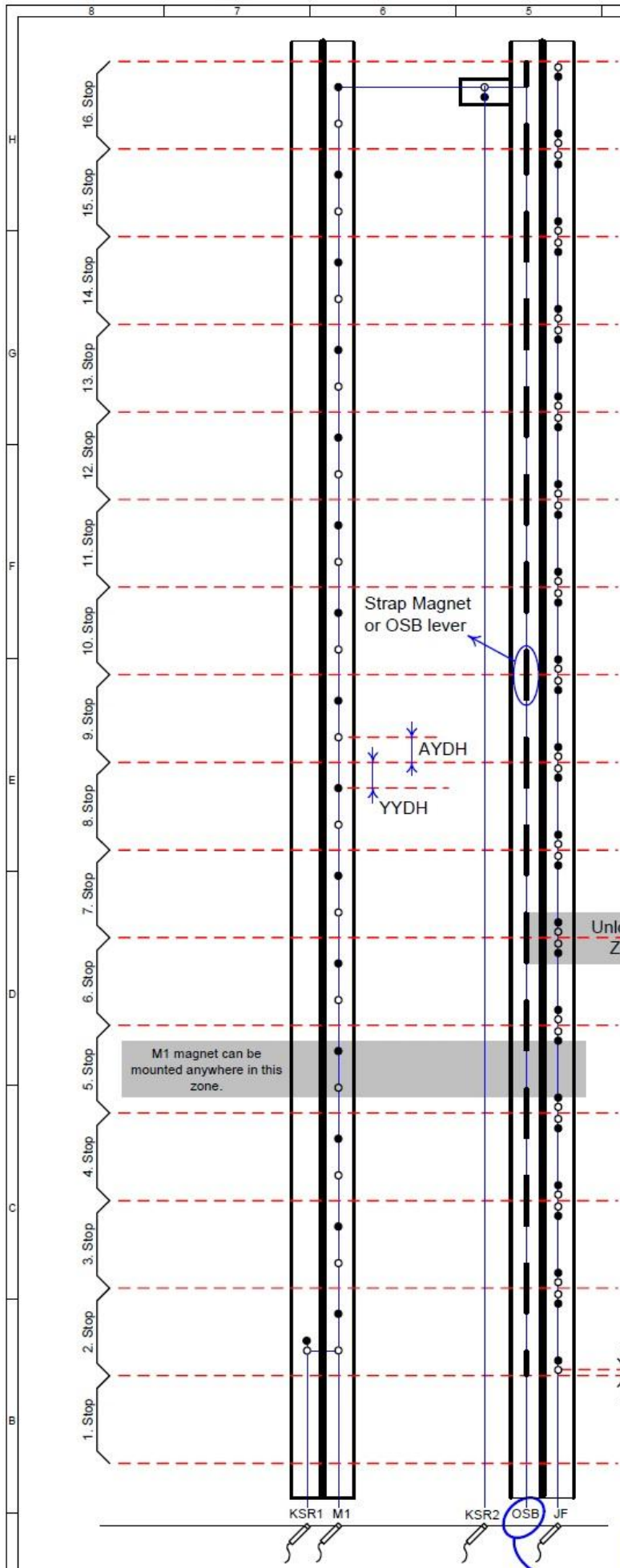

**IMPORTANT NOTE:** EN 81-1 and EN 81-2 give permission for adjust the unlocking zone as maximum 20cm under and 20 cm above from stop floor level. This zone is declared to control card by using strap magnet, mono-stable switch or wheeled switch, OSB lever.

**IMPORTANT NOTE:** Be sure about length of the retractable cam is adequate to length of unlocking zone which was adjusted by yourself. When door pre-opening function is active, the control card will open the door when the OSB led lights. The car must be enter to the cam zone at this time. Otherwise, some permanent damages may occur on your door system.

If the speed of lift is lower than 1 m/sn, to use only M1 magnet is enough. But "P4.4-NeighborStopNumber" parameter has to be adjusted as "CANCEL" CERTAINLY.

**NOTE:** The distance between M1 magnet and floors are shown in the figure as a model. These magnets can be mounted anywhere between two black magnets of JF in the same stop because of to make a floor setting. But the distance must be adjusted as 8-10cm between side by side mounted two M1 magnets.

**NOTE1:** Screw strap magnets on the guide-rail of the car.  
**NOTE2:** It is suggested to use limit switches instead of OSB mono-stable switches.  
**NOTE3:** To make an operation for door pre-opening, ESP card must be integrated and this feature must be activated from the menu.

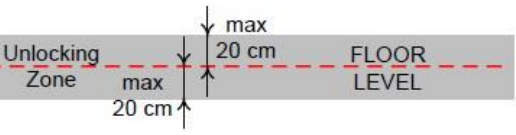

- M1 : Counter bi-stable switch
- OSB : Automatic releiving zone monostable switch or wheeled switch. OSB led must light only at unlocking zone. (Connect to M2 terminal.)
- JF : Floor leveling bistable switch
- KSR1 : Lower limit stopper bi-stable switch
- KSR2 : Higher limit stopper bi-stable switch
- YYDH : Low speed distance for up direction
- AYDH : Low speed distance for down direction
- DM : Stopping distance

- : Bi-stable switch at on state (The led on the controller is light off)
- : Bi-stable switch at off state (The led on the controller is light on)

Use "strap magnet", "mono-stable switch" or "wheeled switch", "OSB lever" as OSB sensor. (Connect to M2 terminal)

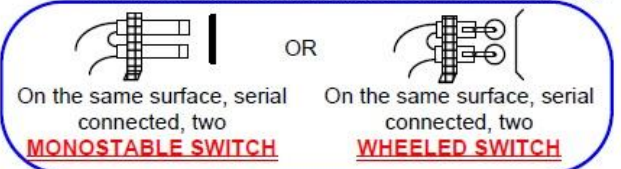

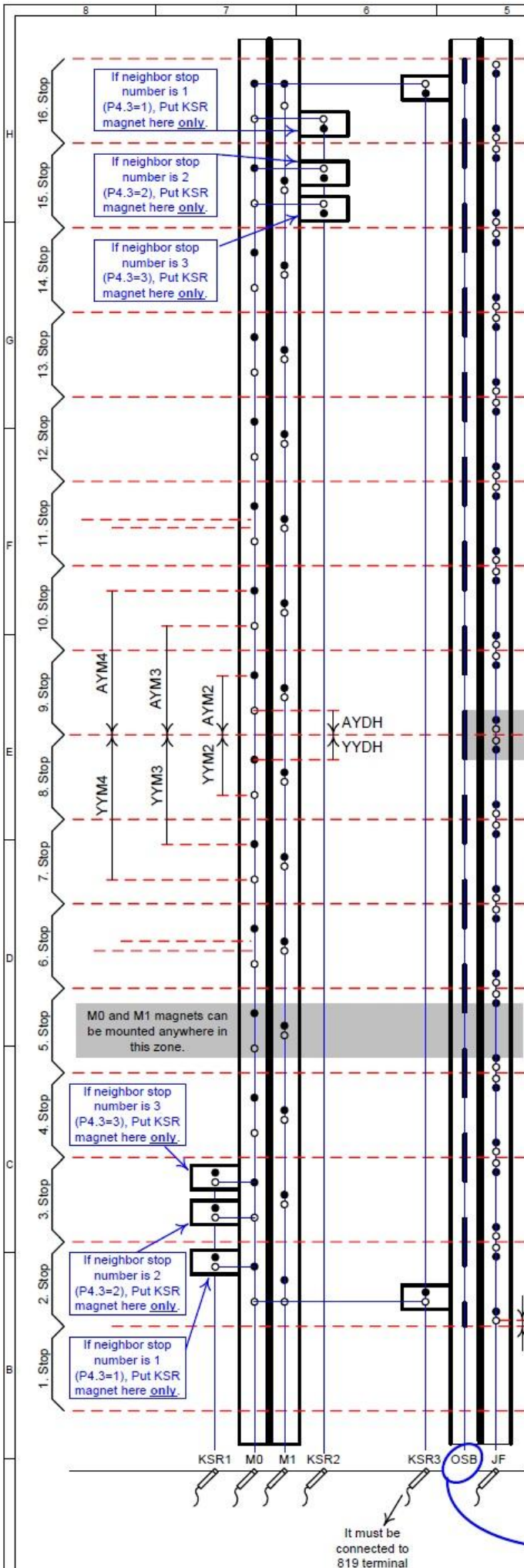

Gizmo control system can set two different slowing down points for neighbor and distant calls for the lifts with speeds more than 1,0m/sec. For neighbor calls the lift starts to slow down in regard to the information coming from M1 magnet.

Neighbor stops number can be adjusted in "P4.3-NeighborStopNumber" parameter. Therefore, deceleration distance for neighbor calls must be like below.

YYDH : Low speed distance for up direction

AYDH : Low speed distance for down direction

On GIZMO, for distant calls, the lift starts to slow down in regard to the information coming from M0 magnet. So, deceleration distances must be like below.

YYM2 : Deceleration distance for up direction in case of neighbor stop number is 1

YYM3 : Deceleration distance for up direction in case of neighbor stop number is 2

YYM4 : Deceleration distance for up direction in case of neighbor stop number is 3

AYM2 : Deceleration distance for down direction in case of neighbor stop number is 1

AYM3 : Deceleration distance for down direction in case of neighbor stop number is 2

AYM4 : Deceleration distance for down direction in case of neighbor stop number is 3

Mount KSR3 lower and higher limit stopper to marked points which are according to "P4.3=NeighborStopNumber" parameter

NOTE: The distance between M0 - M1 magnets and floors are shown in the figure as a model. These magnets can be mounted anywhere between two black magnets of JF in the same stop because of to make a floor setting. But the distance must be adjusted as 8-10cm between two side by side mounted M0 and M1 magnets.

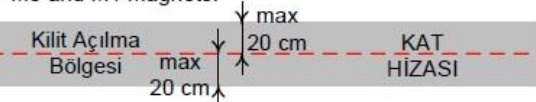

**IMPORTANT NOTE:** EN 81-1 and EN 81-2 give permission for adjust the unlocking zone as maximum 20cm under and 20 cm above from stop floor level. This zone is declared to control card by using strap magnet, mono-stable switch or wheeled switch, OSB lever.

**IMPORTANT NOTE:** Be sure about length of the retractable cam is adequate to length of unlocking zone which was adjusted by yourself. When door pre-opening function is active, the control card will open the door when the OSB led lights. The car must be enter to the cam zone at this time. Otherwise, some permanent damages may occur on your door system.

NOTE1: Screw strap magnets on the guide-rail of the car.

NOTE2: It is suggested to use limit switches instead of OSB mono-stable switches.

NOTE3: To make an operation for door pre-opening, ESP card must be integrated and this feature must be activated from the menu.

M0 : Counter bi-stable switch

M1 : Counter bi-stable switch

OSB : Automatic releveling zone monostable switch or wheeled switch.

OSB led must light only at unlocking zone. (Connect to M2 terminal.)

JF : Floor leveling bistable switch

KSR1 : Lower limit stopper bi-stable switch (Conn. 817 terminal)

KSR2 : Low speed higher limit stopper bi-stable switch (Conn. 818 terminal)

KSR3 : High speed limit stopper bi-stable switch (Connect to 819 terminal)

DM : Stopping distance

○ : Bi-stable switch at on state (The led on the controller is light off)

● : Bi-stable switch at off state (The led on the controller is light on)

Use "strap magnet", "mono-stable switch" or "wheeled switch", "OSB lever" as OSB sensor. (Connect to M2 terminal)

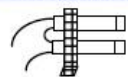

OR

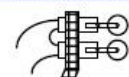

On the same surface, serial connected, two **MONOSTABLE SWITCH**

On the same surface, serial connected, two **WHEELED SWITCH**

**IMPORTANT NOTE:** EN 81-1 and EN 81-2 give permission for adjust the unlocking zone as maximum 20cm under and 20 cm above from stop floor level. This zone is declared to control card by using strap magnet, mono-stable switch or wheeled switch, OSB lever.

**IMPORTANT NOTE:** Be sure about length of the retractable cam is adequate to length of unlocking zone which was adjusted by yourself. When door pre-opening function is active, the control card will open the door when the OSB led lights. The car must be enter to the cam zone at this time. Otherwise, some permanent damages may occur on your door system.

**VERY IMPORTANT !!!**  
OSB led must light only at this zone

FLOOR LEVEL

Unlocking Zone

max 20 cm

max 20 cm

YKSM

AKSM

These magnets must be mounted directly above and under of the unlocking zone.

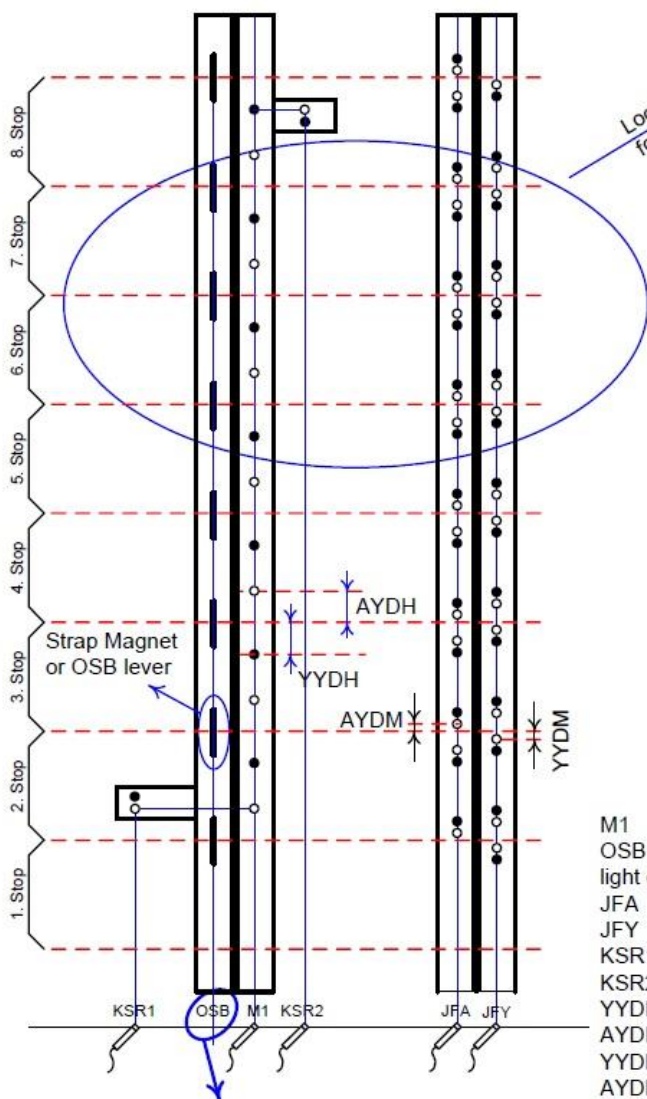

Use "strap magnet", "mono-stable switch" or "wheeled switch", "OSB lever" as OSB sensor.

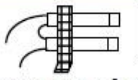

VEYA

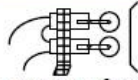

On the same surface, serial connected, two **MONOSTABLE SWITCH**

On the same surface, serial connected, two **WHEELED SWITCH**

- M1 : Counter bi-stable switch
- OSB : Automatic releveing zone monostable switch or wheeled switch. OSB led must light only at unlocking zone. (Connect to M2 terminal.)
- JFA : Floor leveling bi-stable switch for down direction (Connect to M3 terminal)
- JFY : Floor leveling bi-stable switch for up direction (Connect to 142 terminal)
- KSR1 : Lower limit stopper bi-stable switch
- KSR2 : Higher limit stopper bi-stable switch
- YYDH : Low speed distance for up direction
- AYDH : Low speed distance for down direction
- YYDM : Stopping distance for up direction
- AYDM : Stopping distance for down direction
- AKSM : Releveling start distance after slip to down
- YKSM : Releveling start distance after slip to up
- : Bi-stable switch at on state (The led on the controller is light off)
- : Bi-stable switch at off state (The led on the controller is light on)

NOTE1: Screw strap magnets on the guide-rail of the car.

NOTE2: It is suggested to use limit switches instead of OSB mono-stable switches.

NOTE3: To make an operation for door pre-opening, ESP card must be integrated and this feature must be activated from the menu.

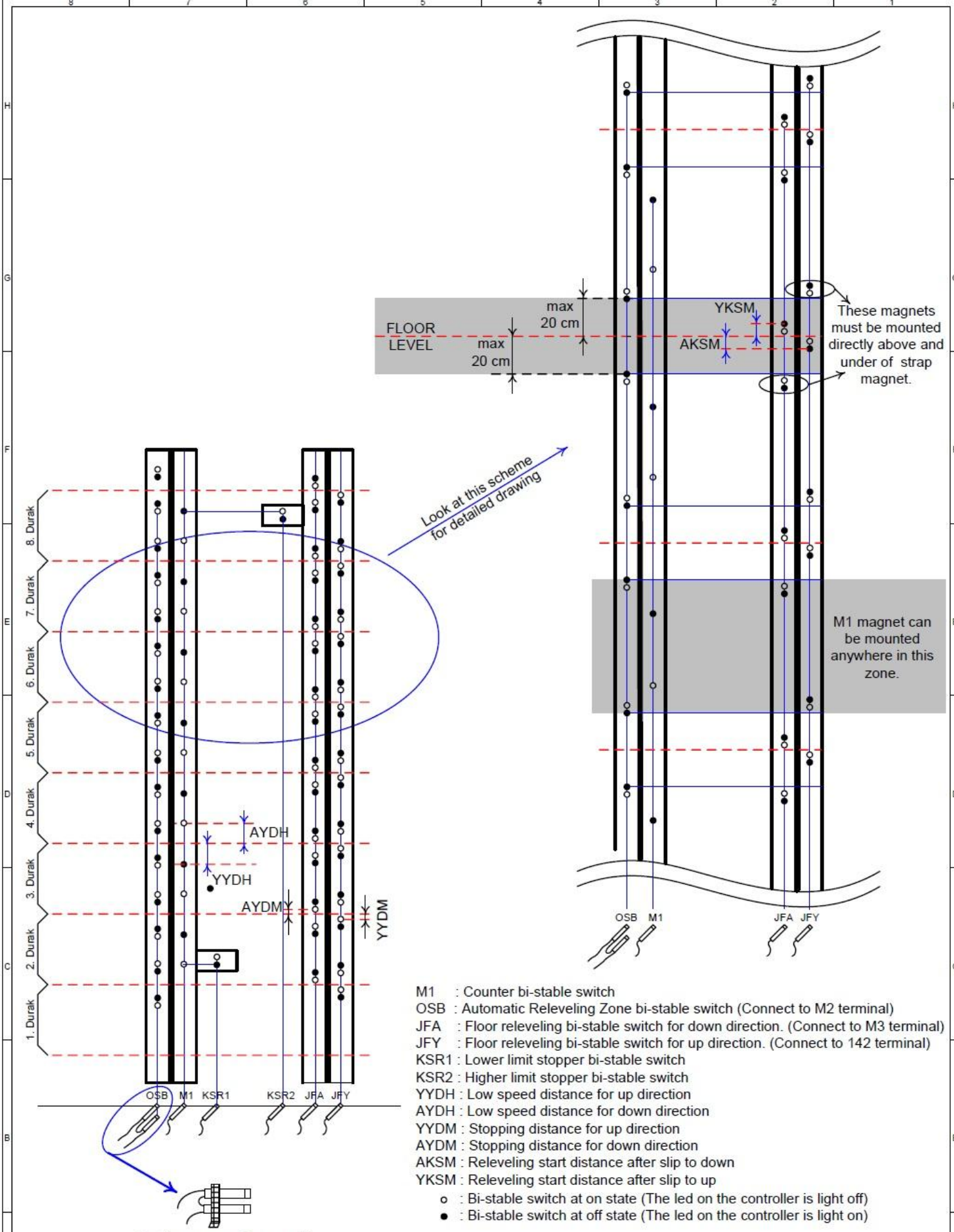

- M1 : Counter bi-stable switch
- OSB : Automatic Releveling Zone bi-stable switch (Connect to M2 terminal)
- JFA : Floor releveling bi-stable switch for down direction. (Connect to M3 terminal)
- JFY : Floor releveling bi-stable switch for up direction. (Connect to 142 terminal)
- KSR1 : Lower limit stopper bi-stable switch
- KSR2 : Higher limit stopper bi-stable switch
- YYDH : Low speed distance for up direction
- AYDH : Low speed distance for down direction
- YYDM : Stopping distance for up direction
- AYDM : Stopping distance for down direction
- AKSM : Releveling start distance after slip to down
- YKSM : Releveling start distance after slip to up
- : Bi-stable switch at on state (The led on the controller is light off)
- : Bi-stable switch at off state (The led on the controller is light on)

NOT: There is no need to use ESP card on hydraulic lifts which haven't got "Releveling with open doors" feature.

## CALL BUTTONS CONNECTION PRINCIPLE

Call Inputs of Control Card

CALL TERMINALS CONTROL TYPE	Call Inputs of Control Card															
	X1	X2	X3	X4	X5	X6	X7	X8	X9	X10	X11	X12	X13	X14	X15	X16
Simple Collective Complex Collective (Maximum 16 stops)	401	402	403	404	405	406	407	408	409	410	411	412	413	414	415	416
One button down collective One button up collective One button full collective (Maximum 8 stops)	601	602	603	604	605	606	607	608	401	402	403	404	405	406	407	408
Two button full collective (Maximum 6 stops)	202	203	204	205	206	301	302	303	304	305	401	402	403	404	405	406

202-216 : Down external calls.  
 301-315 : Up external calls.  
 401-416 : Car internal calls.  
 601-616 : External calls.

## CALL BUTTONS CONNECTION PRINCIPLE WITH ADDITIONAL CALL CARD

Call Inputs of Control Card

Call Inputs of Additional Call Card

CALL TERMINALS CONTROL TYPE	Call Inputs of Control Card																Call Inputs of Additional Call Card															
	X1	X2	X3	X4	X5	X6	X7	X8	X9	X10	X11	X12	X13	X14	X15	X16	Y1	Y2	Y3	Y4	Y5	Y6	Y7	Y8	Y9	Y10	Y11	Y12	Y13	Y14	Y15	Y16
One button down collective One button up collective One button full collective (Maximum 16 stops)	601	602	603	604	605	606	607	608	609	610	611	612	613	614	615	616	401	402	403	404	405	406	407	408	409	410	411	412	413	414	415	416
Two button full collective (Maximum 11 stops)	202	203	204	205	206	207	208	209	210	211	301	302	303	304	305	306	307	308	309	310	401	402	403	404	405	406	407	408	409	410	411	BOŞ



EEM Imp. Exp. Trade Co.  
Lift Control Systems

Tel : +90.332.342 41 27 – 28  
Fax : +90.332.342 41 29

www.eem.com.tr

Project Name GİZMO Lift Control System

Drawing Name Call Buttons Connection Principal (Car Communication : Parallel, Lift Groups: Simplex)

Description

Version 3.2

Date 03.09.2008



Drawer ZD - BA

Control SH

Draw No: 6A Page 62

## CALL BUTTONS CONNECTION PRINCIPAL

Call Inputs of Control Card

CALL TERMINALS CONTROL TYPE	X1	X2	X3	X4	X5	X6	X7	X8	X9	X10	X11	X12	X13	X14	X15	X16
Simple Collective																
Complex Collective																
One button down collective	601	602	603	604	605	606	607	608	609	610	611	612	613	614	615	616
One button up collective																
One button full collective (Maximum 16 stops)																
Two button full collective (Maximum 9 stops)	202	203	204	205	206	207	208	209	301	302	303	304	305	306	307	308

NOTE: Car calls are connected to serial communication card which is mounted to above the car.

- 202-216 : Down external calls.
- 301-315 : Up external calls.
- 401-416 : Car internal calls.
- 601-616 : External calls.

## CALL BUTTONS CONNECTION PRINCIPAL WITH ADDITIONAL CALL CARD

Call Inputs of Control Card

Call Inputs of Additional Call Card

CALL TERMINALS CONTROL TYPE	X1	X2	X3	X4	X5	X6	X7	X8	X9	X10	X11	X12	X13	X14	X15	X16												Y1	Y2	Y3	Y4	Y5	Y6	Y7	Y8	Y9	Y10	Y11	Y12	Y13	Y14	Y15	Y16
Two button full collective (Maximum 16 stops)	BOŞ	202	203	204	205	206	207	208	209	210	211	212	213	214	215	216												301	302	303	304	305	306	307	308	309	310	311	312	313	314	315	BOŞ



EEM Imp. Exp. Trade Co.  
Lift Control Systems

Tel : +90.332. 342 41 27 – 28  
Fax : +90.332. 342 41 29

www.eem.com.tr

Project Name GIZMO Lift Control System

Drawing Name Call Buttons Connection Principal (Car Communication : Serial, Lift Groups: Simplex)

Description

Version 3.2

Date 03.09.2008



Drawer ZD - BA

Control SH

Draw No: 6B Page 63

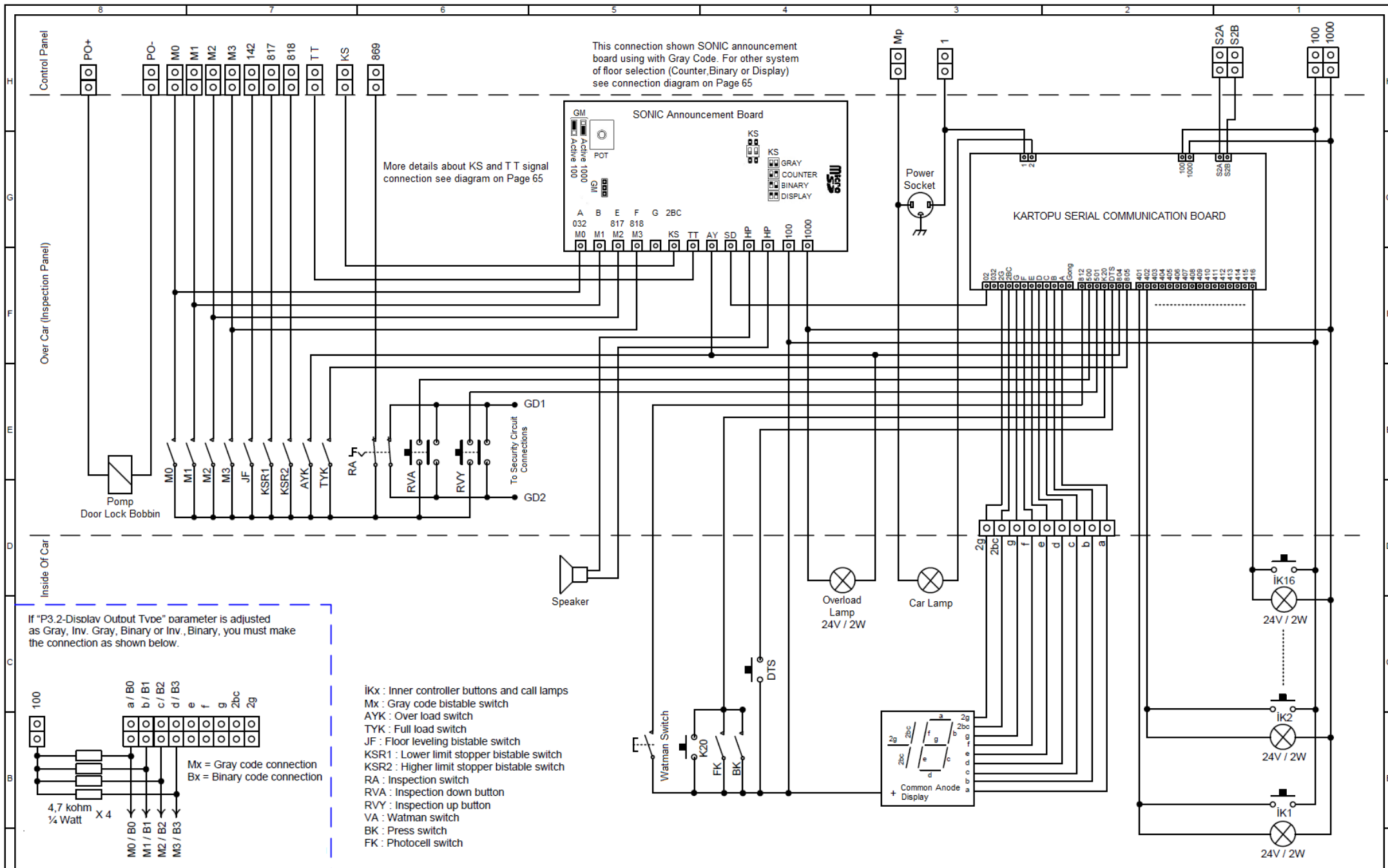

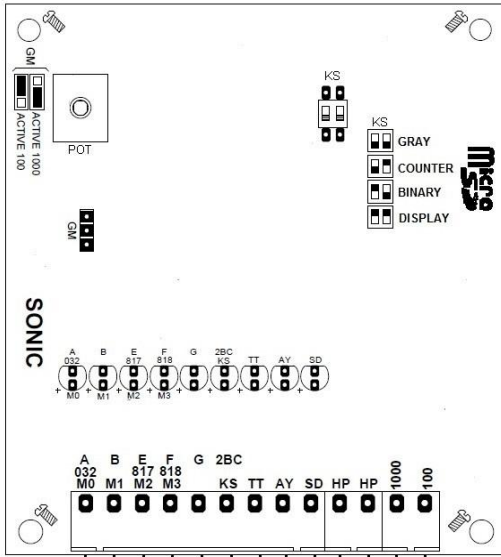

**In system that use Gray code as floor selection**

1. Set KS switch as GRAY position.
2. Set GM jumper as ACTIVE 100 position.
3. Connect speaker to HP-HP terminals.
4. Connect M0 signal to M0 terminal.
5. Connect M1 signal to M1 terminal.
6. Connect M2 signal to M2 terminal.
7. Connect M3 signal to M3 terminal.
8. Connect trigger signal to TT terminal.
9. Connect 804 signal to AY terminal.
10. Connect 02 signal to SD terminal.
11. Connect 1000 cable to 1000 terminal.
12. Connect 100 cable to 100 terminal.

**In system that use Binary code as floor selection**

1. Set KS switch as BINARY position.
2. Set GM jumper as ACTIVE 100 position.
3. Connect speaker to HP-HP terminals.
4. Connect M0 signal to M0 terminal.
5. Connect M1 signal to M1 terminal.
6. Connect M2 signal to M2 terminal.
7. Connect M3 signal to M3 terminal.
8. Connect trigger signal to TT terminal.
9. Connect 804 signal to AY terminal.
10. Connect 02 signal to SD terminal.
11. Connect 1000 cable to 1000 terminal.
12. Connect 100 cable to 100 terminal.

**In system that use Counter as floor selection**

1. Set KS switch as COUNTER position.
2. Set GM jumper as ACTIVE 100 position.
3. Connect speaker to HP-HP terminals.
4. Connect 032 signal to 032 terminal.
5. Connect M1 signal to M1 terminal.
6. Connect 817 signal to 817 terminal.
7. Connect trigger signal to TT terminal.
8. Connect 804 signal to AY terminal.
9. Connect 02 signal to SD terminal.
10. Connect 1000 cable to 1000 terminal.
11. Connect 100 cable to 100 terminal.

**Set Working Mode at First**

Can be selected 4 different way for working mode. Cut off energy and eject microSD card from board and to set. Give energy and you can hear sound signal that specify set mode. Set KS switch which mode you want. After set process cut off energy. MicroSD card attach to board and give energy. Working mode saved permanently. Not affected by power cuts.

KS

- Start from basement and not play background music
- Start from entrance and not play background music
- Start from basement and play background music
- Start from entrance and play background music

**Note 1:** Connect power SONIC board from control panel 100 and 1000 terminal and connect to battery over HSK-1 Reserve relay. When power cuts, rescue board will work and SONIC play rescue announcement. In addition to the supply connection must be connected diodes as shown connection diagram.

**Note 2:** To play rescue announcement using Reserve relay on HSK-1 rescue board. Reserve relay is working with RM relay. Connect 24VDC to Reserve relay COM terminal. Reserve relay NO terminal connect to KS terminal and SONIC board 100 and 1000 terminal.

**Note 3:** Connect 24VDC from High speed contactor NO terminal for triggering signal to play background music and floor announcement.

KS: Rescue Signal  
 TT: Trigger Signal  
 AY: Overloaded Signal  
 SD: Out of Service Signal  
 HP: Speaker Connection  
 1000: 24VDC (-)  
 100: 24VDC (+)

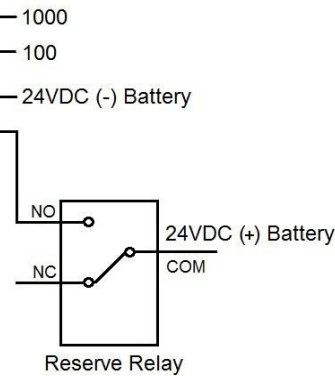

EEM Imp. Exp. Trade Co.  
 Lift Control System

Tel : +90 332 346 46 56 - 66  
 Fax : +90 332 345 56 76

www.eem.com.tr

Project Name SONIC Announcement Board Connection

Drawing Name SONIC board connection when using floor selector as Gray code, Counter and Binary code

Description



Drawer HU  
 Controller BA

Version 1.00

Date 24.05.2013

Drawing No 1A

Page 65

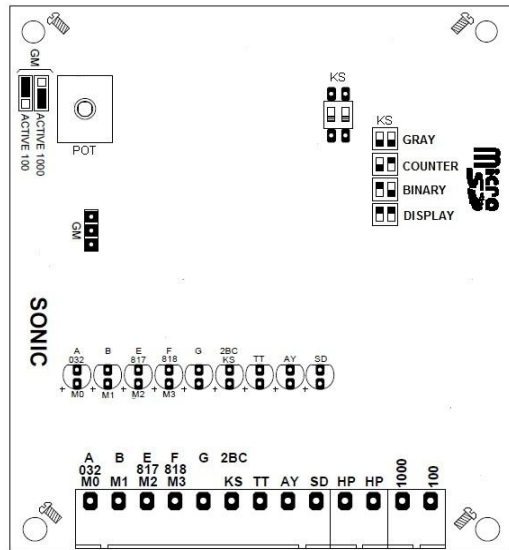

**In system that use 7 Segment Display as floor selection**

1. Set KS switch as DISPLAY position.
2. Set GM jumper as ACTIVE 1000 position.
3. Connect speaker to HP-HP terminals.
4. Connect A signal to A terminal.
5. Connect B signal to B terminal.
6. Connect E signal to E terminal.
7. Connect F signal to F terminal.
8. Connect G signal to G terminal.
9. Connect 2BC signal to 2BC terminal.
10. Connect trigger signal to TT terminal.
11. Connect 804 signal to AY terminal.
12. Connect 02 signal to SD terminal.
13. Connect 1000 cable to 1000 terminal.
14. Connect 100 cable to 100 terminal.

**Note 1:** Connect power SONIC board from control panel 100 and 1000 terminal and connect to battery over HSK-1 Reserve relay. When power cuts, rescue board will work and SONIC play rescue announcement. In addition to the supply connection must be connected diodes as shown connection diagram.

**Note 2:** To play rescue announcement using Reserve relay on HSK-1 rescue board. Reserve relay is working with RM relay. Connect 24VDC to Reserve relay COM terminal. Reserve relay NO terminal connect to KS terminal and SONIC board 100 and 1000 terminal.

**Note 3:** To keep 7 segment display signal impairment adding diode to A,B,E,F,G and 2BC terminal on SONIC board.

**Note 4:** If stop number greater than 10, not use rescue announcement

**Note 5:** Connect 24VDC from High speed contactor NO terminal for triggering signal to play background music and floor announcement.

**Set Working Mode at First**

Can be selected 4 different way for working mode. Cut off energy and eject microSD card from board and to set. Give energy and you can hear sound signal that specify set mode. Set KS switch which mode you want. After set process cut off energy. MicroSD card attach to board and give energy. Working mode saved permanently. Not affected by power cuts.

- KS
- Start from basement and not play background music
  - Start from entrance and not play background music
  - Start from basement and play background music
  - Start from entrance and play background music

KS: Rescue Signal  
 TT: Trigger Signal  
 AY: Overloaded Signal  
 SD: Out of Service Signal  
 HP: Speaker Connection  
 1000: 24VDC (-)  
 100: 24VDC (+)

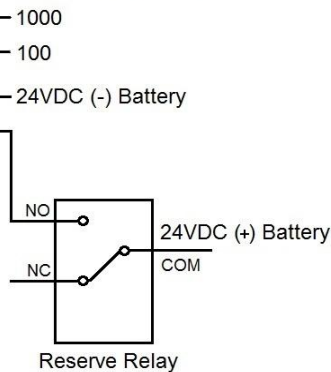

EEM Imp. Exp. Trade Co.  
 Lift Control System

Tel : +90 332 346 46 56 - 66  
 Fax : +90 332 345 56 76

www.eem.com.tr

Project Name SONIC Announcement Board Connection

Drawing Name SONIC board connection when using floor selector as Display mode

Description

Version 1.00

Date 24.05.2013



Drawer HU

Controller BA

Drawing No 2A

Page 66

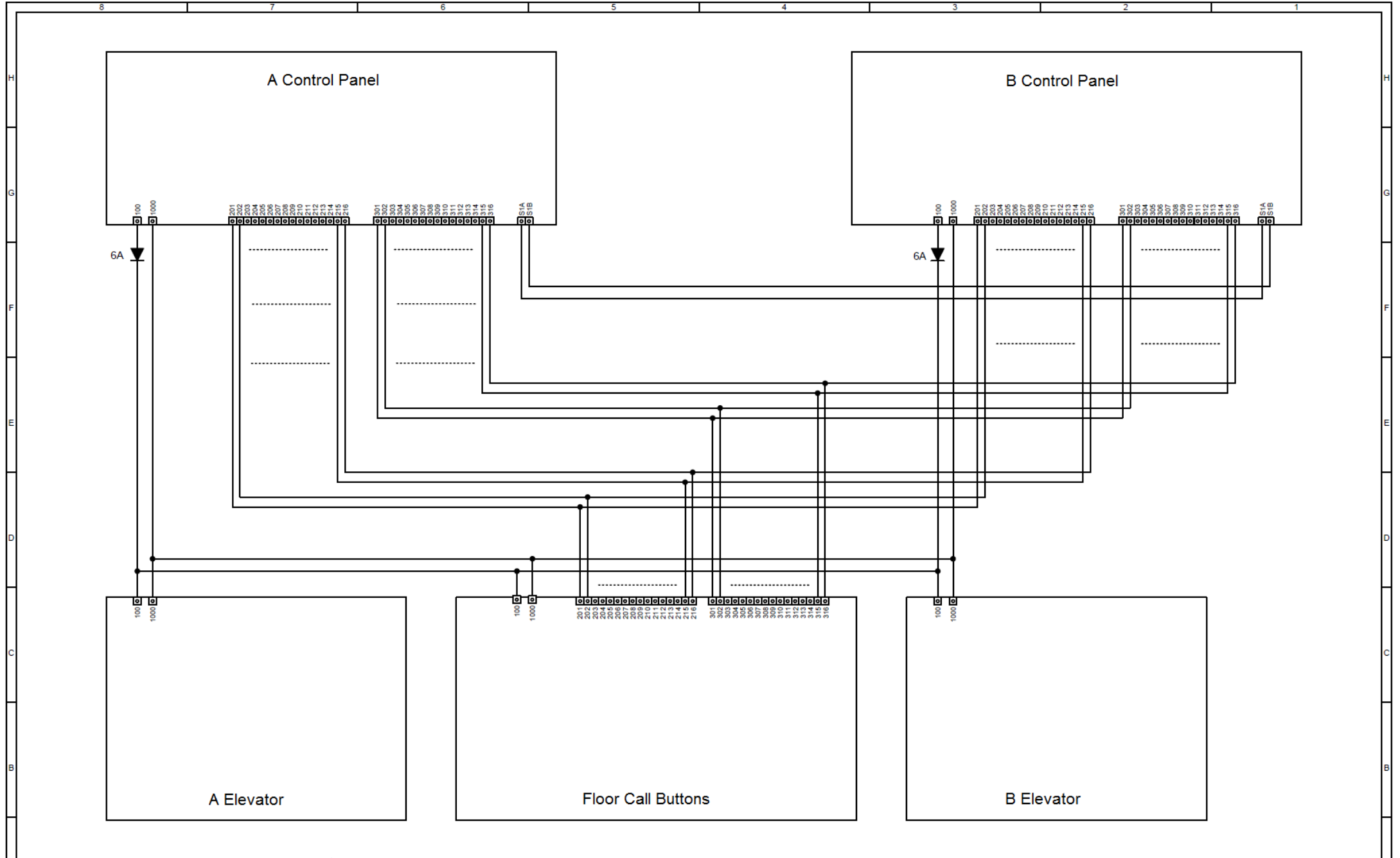

EEM Imp. Exp. Trade Co.  
Lift Control Systems

Tel : +90.332.346 46 56 - 66  
Fax : +90.332.346 46 76

www.eem.com.tr

Project Name GIZMO Lift Control System

Drawing Name Two button collective floor call button connection for duplex elevator

Description



Drawer HU

Control BA

Version 3.2

Date 22.12.2014

Draw No: 1A

Page 67

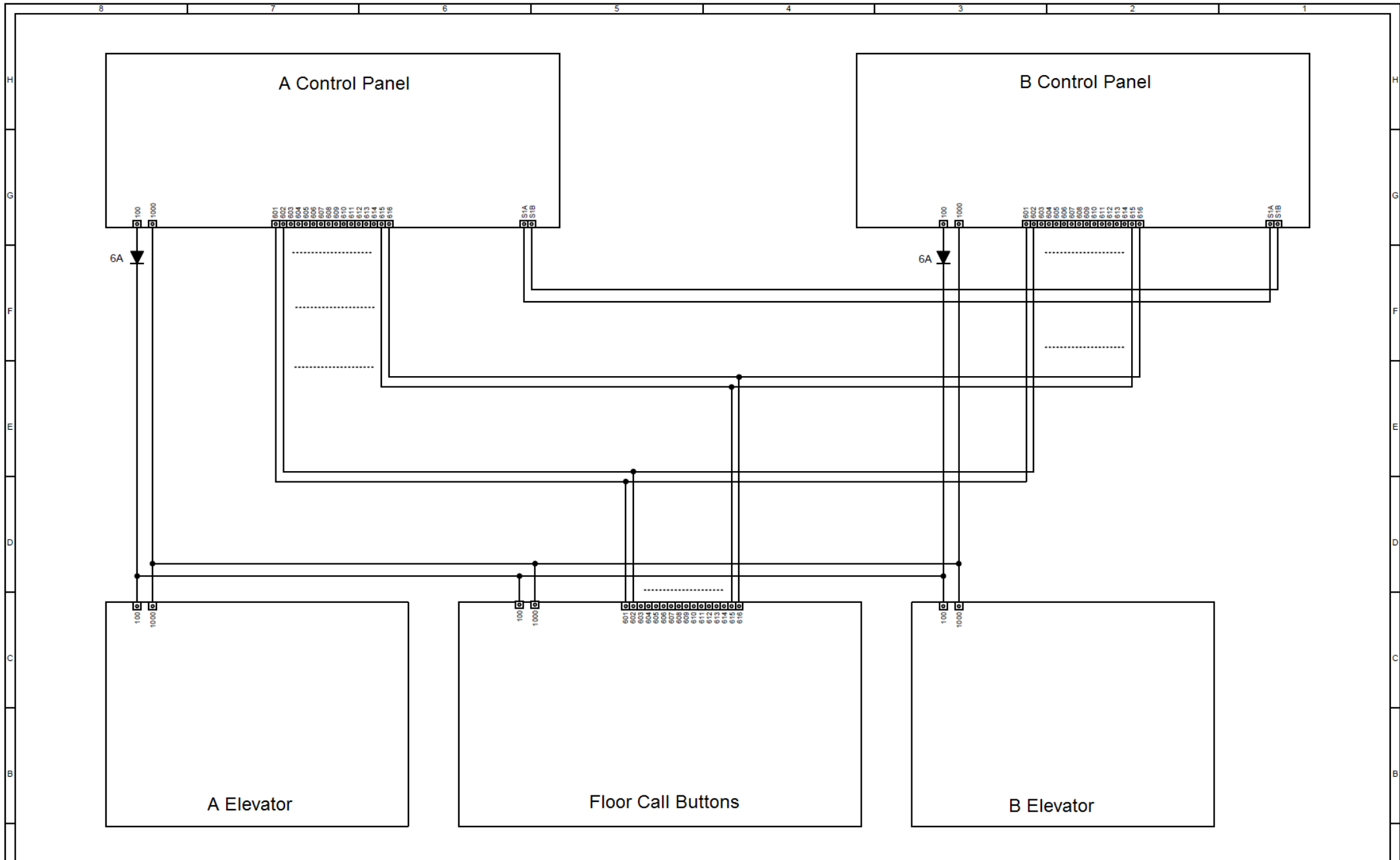

EEM Imp. Exp. Trade Co.  
Lift Control Systems

Tel : +90.332.346 46 56 - 66  
Fax : +90.332.346 46 76

www.eem.com.tr

Project Name GIZMO Lift Control System

Drawing Name One button collective floor call buttons connection for dublex elevator

Description



Drawer HU

Control BA

Version 3.2

Date 22.12.2014

Draw No: 1A

Page 68

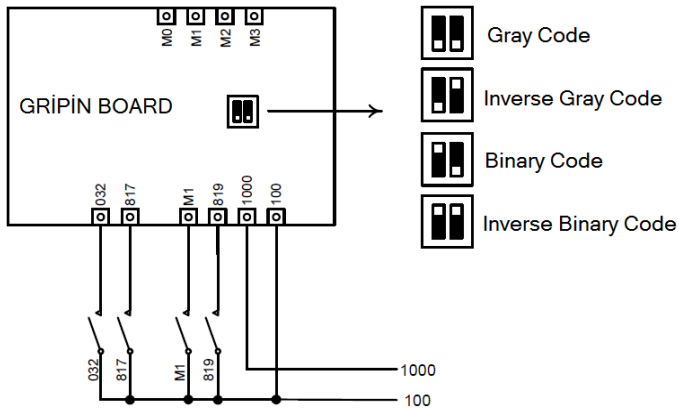

**Gripin Board:**

For elevators, in which COUNTER system has been used as floor selection, Gripin board transforms the floor the cabin is placed to the gray, inverse gray, binary and inverse binary code for different needs.

NOTE: For elevators with 1m/s and lower speed leave the connection 819 unconnected. For elevators with speeds higher than 1m/s, 819 cable must be connected to 819 connector.

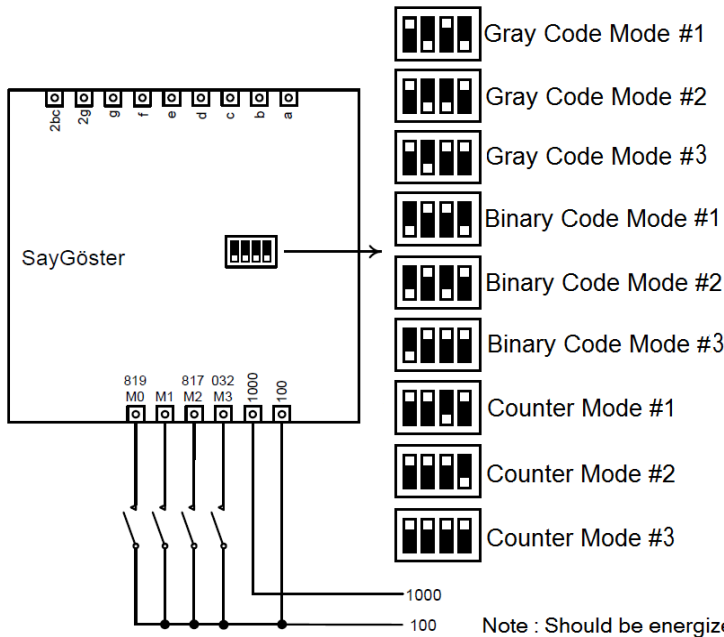

In systems that use GRAY CODE as floor selection,

1. Connect M0 cable to M0 connector
2. Connect M1 cable to M1 connector
3. Connect M2 cable to M2 connector
4. Connect M3 cable to M3 connector
5. Connect 1000 cable to 1000 connector
6. Connect 100 cable to 100 connector

In systems that use BINARY CODE as floor selection,

1. Connect M0 cable to M0 connector
2. Connect M1 cable to M1 connector
3. Connect M2 cable to M2 connector
4. Connect M3 cable to M3 connector
5. Connect 1000 cable to 1000 connector
6. Connect 100 cable to 100 connector

In systems that use COUNTER as floor selection,

1. Connect M1 cable to M1 connector
2. Connect 817 cable to 817 connector
3. Connect 032 cable to 032 connector
4. Connect 1000 cable to 1000 connector
5. Connect 100 cable to 100 connector

Description about modes:

- Gray Code Mode #1 : To display number from -4 to 11 with use Gray Code
- Gray Code Mode #2 : To display number from 0 to 15 with use Gray Code
- Gray Code Mode #3 : To display number from -1 to 14 with use Gray Code
- Binary Code Mode #1 : To display number from -4 to 11 with use Binary Code
- Binary Code Mode #2 : To display number from 0 to 15 with use Binary Code
- Binary Code Mode #3 : To display number from -1 to 14 with use Binary Code
- Counter Mode #1 : To display number from -4 to 11 with use Counter
- Counter Mode #2 : To display number from 0 to 15 with use Counter
- Counter Mode #3 : To display number from -1 to 14 with use Counter

Note : Should be energized after mode change



EEM Imp. Exp. Trade Co.  
Lift Control System

Tel: +90.332.346 46 56 - 66  
Fax: +90.332.346 46 76

www.eem.com.tr

Project Name GİZMO Lift Control System

Drawing Name GRIPIN and SAYGOSTER Board Connection

Description



Drawer HU  
Control BA

Version 3.2

Date 22.12.2014

Drawing No:1A

Page 69



**TÜRK STANDARDLARI ENSTİTÜSÜ**  
TURKISH STANDARDS INSTITUTION

## AT UYGUNLUK BELGESİ

- Belge No** : 1783 – TR/AT - 001
- Ürün Tanımı** : ASANSÖR KUMANDA KARTI
- Ticari Marka, Ürün Tipi** : Markası “EEM”, Tipi “GİZMO”
- İmalatçının Adı ve Adresi** : EEM İTH. İHR. PAZ. ve TİC. A.Ş.  
Kunduracılar Sanayi Sitesi Dikimhane Sokak. No: 19,  
Selçuklu / KONYA / TÜRKİYE
- Belge Sahibinin Adı ve Adresi** : EEM İTH. İHR. PAZ. ve TİC. A.Ş.  
Kunduracılar Sanayi Sitesi Dikimhane Sokak. No: 19,  
Selçuklu / KONYA / TÜRKİYE
- İlgili Yönetmelikler** : ASANSÖR DİREKTİFİ 95/16/AT, EMC DİREKTİFİ 89/336/EC
- Test Laboratuvarı** : ELDAŞ, ANKARA
- Laboratuvar Raporunun** : 03/07/2007, EMC-070619-01
- Tarih ve Numarası**
- Ekler** : Tip inceleme belgesine ait deney raporları
- Açıklamalar** : Asansör kumanda kartı EN 81-1 / EN 81-2 EK F6'ya göre laboratuvar testlerine tabi tutulmamıştır.
- Sonuç** : Asansör kumanda kartı yukarıdaki açıklamalar dikkate alındığında ilgili yönetmeliklerin şartlarını karşılamaktadır.



Mehmet EYÜCÜ  
Ürün Belgelendirme Merkezi Başkanı

*TSE tarafından verilen bu belge, kuruluşu uymak zorunda olduğu yasal zorunluluklardan muaf tutmaz.*

## AB UYGUNLUK BEYANI EC- DECLARATION of CONFORMITY

İMALATÇI / MANUFACTURER :

EEM İTH. İHR. PAZ.ve TİC. A.Ş.

TİP / TYPE :

Gizmo

İMALATÇI ADRESİ / MANUFACTURER ADDRESS :

Fevzi Çakmak Mah. Yaş Meyve ve Sebzeciler Sit.  
10515. Sok. No:24 Karatay / Konya / Türkiye

ÜRETİM YILI / YEAR OF MANUFACTURE :

Etiket Üzerinde / See data label on product

ÜRÜNÜN ADI / PRODUCT NAME :

Asansör Kumanda Kartı / Lift Controller Board

SERİ NO / SERIAL NUMBER :

Etiket Üzerinde / See data label on product

### UYGULANAN STANDARTLAR / THE FOLLOWING STANDARTS :

EN 81-1, EN 81-2, EN 61000-6-1:2001, TS EN 61000-6-1:2003-01,  
EN 61000-6-3:2001/A11:2004, TS EN 61000-6-3:2003/A11:2006-01

### UYGULANAN DİREKTİFLER / THE FOLLOWING DIRECTIVES :

Asansör Direktifi 95/16/AT / Lift Directive 95/16/EC  
EMC Direktifi / EMC Directive 89/336/EC

Üzerinde seri numarası yer alan ürün için, kullanıcıya teslim edilen kullanım kılavuzundaki şartlara uyulması durumunda yukarıda belirtilen standartlara ve direktiflere uygunluğunu beyan ederiz.

We declare eligibility of above mentioned standards and directives to comply with the represented conditions on the user manual for the serial number on the product.

### TEST LABORATUARI / TEST LABORATORY

Eldaş Elektrik Elektronik A.Ş.  
1.Organize San. Bölgesi. Büyük Selçuklu Bulvarı  
No:2/A 06935 Sincan / Ankara / Türkiye

### ONAYLANMIŞ KURULUŞ / NOTIFIED BODY

Türk Standartları Enstitüsü Ürün Belgelendirme  
Merkezi Direktifler Müdürlüğü  
Necatibey cad. No:112 Bakanlıklar / Ankara / Türkiye

EMC TEST BELGE NO / EMC TEST CERTIFICATE NUMBER : EMC-070619-01

FİRMA SORUMLUSU / RESPONSE OF COMPANY : Yön.Kur.Bşk. Aşır AKDEMİR

YER-TARİH / PLACE-DATE : KONYA / TÜRKİYE / 03.07.2007

YETKİLİ İMZA / LEGALLY BINDING SIGNATURE :

Dear Customer,

We, as EEM Co., Ltd. give utmost importance to the customer satisfaction. We are seeking your help about this. Please contribute developing our products by kindly spending a few minutes of your precious time to fill up this form and send it to us by post or fax. Thank you very much for your contribution.

❖ Please introduce us your firm?

Firm Name: \_\_\_\_\_ Contact Person \_\_\_\_\_  
 Address : \_\_\_\_\_  
 Tel : \_\_\_\_\_  
 Fax : \_\_\_\_\_

❖ What is your firm's area of interest?

- Installation  Electronic equipment for lifts  
 Equipment wholesale  Mechanical parts production  
 Control panel production  Other .....

❖ How did you hear about us?

- Fair  Internet  
 Advise  Magazine/Newspaper ads  
 Other .....

❖ Which products of ours have you used? Are you satisfied with our service?

Service\ Product	Rescuer	Control Card	Speed Control Eq.	Control Panel	Revision Set	Door Card
Sale	😊 😐 😞	😊 😐 😞	😊 😐 😞	😊 😐 😞	😊 😐 😞	😊 😐 😞
Price	😊 😐 😞	😊 😐 😞	😊 😐 😞	😊 😐 😞	😊 😐 😞	😊 😐 😞
Quality	😊 😐 😞	😊 😐 😞	😊 😐 😞	😊 😐 😞	😊 😐 😞	😊 😐 😞
Delivery	😊 😐 😞	😊 😐 😞	😊 😐 😞	😊 😐 😞	😊 😐 😞	😊 😐 😞
Installation	😊 😐 😞	😊 😐 😞	😊 😐 😞	😊 😐 😞	😊 😐 😞	😊 😐 😞
Technical Support	😊 😐 😞	😊 😐 😞	😊 😐 😞	😊 😐 😞	😊 😐 😞	😊 😐 😞
After Sale Service	😊 😐 😞	😊 😐 😞	😊 😐 😞	😊 😐 😞	😊 😐 😞	😊 😐 😞

😊 : Good    😐 : Medium    😞 : Bad

❖ Are you seeking for a new product, technical support or supplier firm?

Yes     No    Explanation:.....

❖ In your opinion, what are the two prime factors for a product? (Please make at most two choices. )

- Confidence     Easy Installation     Price     After Sales Service  
 Delivery Time     Technical Support



SENDER :

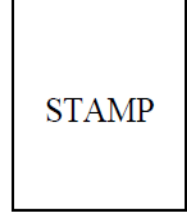

ADDRESS :

EEM İthalat İhracat Pazarlama ve Ticaret A.Ş  
Fevzi Çakmak Mah. MODESA Sanayi Sitesi 10735. Sok. No:3  
Karatay/KONYA/TURKIYE

Curve from here!

---

**eem**  
LIFT CONTROLLER and RESCUE SYSTEM



**EEM İTH. İHR. PAZ. ve TİC. AŞ.**

Tel: +90 332 346 46 56-66

Fax: +90 332 346 46 76

Fevzi Çakmak Mah.  
MODESA Sanayi Sitesi  
10735. Sok. No:3  
Karatay / Konya / Türkiye

[www.eem.com.tr](http://www.eem.com.tr)  
[bilgi@eem.com.tr](mailto:bilgi@eem.com.tr)